

(19)



(11)

EP 1 784 819 B1

(12)

EUROPEAN PATENT SPECIFICATION

(45) Date of publication and mention of the grant of the patent:
30.04.2008 Bulletin 2008/18

(51) Int Cl.:
G10L 19/00^(2006.01)

(21) Application number: **05798859.4**

(86) International application number:
PCT/EP2005/011663

(22) Date of filing: **31.10.2005**

(87) International publication number:
WO 2006/048226 (11.05.2006 Gazette 2006/19)

(54) **STEREO COMPATIBLE MULTI-CHANNEL AUDIO CODING**

STEREOKOMPATIBLE MEHRKANAL-AUDIOKODIERUNG

CODAGE AUDIO MULTICANAL COMPATIBLE STEREO

(84) Designated Contracting States:
AT BE BG CH CY CZ DE DK EE ES FI FR GB GR HU IE IS IT LI LT LU LV MC NL PL PT RO SE SI SK TR

- **VILLEMÖES, Lars**
175 56 Järfälla (SE)
- **RÖDEN, Jonas**
169 55 Solna (SE)
- **ENGDEGARD, Jonas**
115 43 Stockholm (SE)

(30) Priority: **02.11.2004 SE 0402650**

(43) Date of publication of application:
16.05.2007 Bulletin 2007/20

(74) Representative: **Zinkler, Franz et al**
Schoppe, Zimmermann, Stöckeler & Zinkler
Postfach 246
82043 Pullach bei München (DE)

- (73) Proprietors:
- **Coding Technologies AB**
113 52 Stockholm (SE)
 - **Koninklijke Philips Electronics N.V.**
5621 BA Eindhoven (NL)

(56) References cited:
WO-A-20/05101370

- (72) Inventors:
- **PUHNHAGEN, Heiko**
113 30 Stockholm (SE)
 - **BREEBAART, Jeroen**
5621 BA Eindhoven (NL)
 - **SCHUIJERS, Erik**
5621 BA Eindhoven (NL)

- **FALLER C: "Coding of spatial audio compatible with different playback formats" AUDIO ENGINEERING SOCIETY CONVENTION PAPER, 117TH AES CONVENTION, [Online] 28 October 2004 (2004-10-28), pages 1-12, XP002364728 San Francisco, CA, USA Retrieved from the Internet: URL: http://lcavwww.epfl.ch/~cfaller/mypapers/faller04_AES117_BCC_C2E.pdf [retrieved on 2006-01-26]**

EP 1 784 819 B1

Note: Within nine months from the publication of the mention of the grant of the European patent, any person may give notice to the European Patent Office of opposition to the European patent granted. Notice of opposition shall be filed in a written reasoned statement. It shall not be deemed to have been filed until the opposition fee has been paid. (Art. 99(1) European Patent Convention).

Description

[0001] The present invention relates to multi-channel audio coding and in particular to a concept of generating and using a parametric representation of a multi-channel audio signal that is fully backwards compatible to parametric stereo playback environments.

[0002] The present invention relates to coding of multi-channel representations of audio signals using spatial audio parameters in a manner that is compatible with coding of 2-channel stereo signals using parametric stereo parameters. The present invention teaches new methods for efficient coding of both spatial audio parameters and parametric stereo parameters and for embedding the coded parameters in a bitstream in a backward compatible manner. In particular it aims at minimizing the overall bitrate for the parametric stereo and spatial audio parameters in the backward compatible bitstream without compromising the quality of the decoded stereo or multi-channel audio signal. When a slightly compromised quality of the decoded stereo signal is acceptable, the overall bitrate can be reduced even further.

[0003] Recently, multi-channel audio reproduction techniques are becoming more and more important. Aiming at an efficient transmission of multi-channel audio signals having 5 or more separate audio channels, several ways of compressing a stereo or multi-channel signal have been developed. Recent approaches for the parametric coding of multi-channel audio signals (parametric stereo (PS), Binaural Cue Coding (BCC) etc.) represent a multi-channel audio signal by means of a down-mix signal (could be monophonic or comprise several channels) and parametric side information, also referred to as "spatial cues", characterizing its perceived spatial sound stage.

[0004] A multi-channel encoding device generally receives - as input - at least two channels, and outputs one or more carrier channels and parametric data. The parametric data is derived such that, in a decoder, an approximation of the original multi-channel signal can be calculated. Normally, the carrier channel (channels) will include subband samples, spectral coefficients, time domain samples, etc., which provide a comparatively fine representation of the underlying signal, while the parametric data do not include such samples of spectral coefficients but include control parameters for controlling a certain reconstruction algorithm instead. Such a reconstruction could comprise weighting by multiplication, time shifting, frequency shifting, phase shifting, etc. Thus, the parametric data includes only a comparatively coarse representation of the signal or the associated channel.

[0005] The binaural cue coding (BCC) technique is described in a number of publications, as in "Binaural Cue Coding applied to Stereo and Multi-Channel Audio Compression", C. Faller, F. Baumgarte, AES convention paper 5574, May 2002, Munich, in the 2 ICASSP publications "Estimation of auditory spatial cues for binaural cue coding", and "Binaural cue coding: a normal and efficient representation of spatial audio", both authored by C. Faller, and F. Baumgarte, Orlando, FL, May 2002.

[0006] In BCC encoding, a number of audio input channels are converted to a spectral representation using a DFT (Discrete Fourier Transform) based transform with overlapping windows. The resulting uniform spectrum is then divided into non-overlapping partitions. Each partition has a bandwidth proportional to the equivalent rectangular bandwidth (ERB). Then, spatial parameters called ICLD (Inter-Channel Level Difference) and ICTD (Inter-Channel Time Difference) are estimated for each partition. The ICLD parameter describes a level difference between two channels and the ICTD parameter describes the time difference (phase shift) between two signals of different channels. The level differences and the time differences are normally given for each channel with respect to a reference channel. After the derivation of these parameters, the parameters are quantized and finally encoded for transmission.

[0007] Although ICLD and ICTD parameters represent the most important sound source localization parameters, a spatial representation using these parameters can be enhanced by introducing additional parameters.

[0008] A related technique, called "parametric stereo" describes the parametric coding of a two-channel stereo signal based on a transmitted mono signal plus parameter side information. Three types of spatial parameters, referred to as inter-channel intensity difference (IIDs), inter-channel phase differences (IPDs), and inter-channel coherence (IC) are introduced. The extension of the spatial parameter set with a coherence parameter (correlation parameter) enables a parametrization of the perceived spatial "diffuseness" or spatial "compactness" of the sound stage. Parametric stereo is described in more detail in: "Parametric Coding of stereo audio", J. Breebaart, S. van de Par, A. Kohlrausch, E. Schuijers (2005) *Eurasip, J. Applied Signal Proc.* 9, pages 1305-1322", in "High-Quality Parametric Spatial Audio Coding at Low Bitrates", J. Breebaart, S. van de Par, A. Kohlrausch, E. Schuijers, AES 116th Convention, Preprint 6072, Berlin, May 2004, and in "Low Complexity Parametric Stereo Coding", E. Schuijers, J. Breebaart, H. Purnhagen, J. Engdegard, AES 116th Convention, Preprint 6073, Berlin, May 2004.

[0009] As mentioned above, systems for parametric stereo coding as well as for spatial audio coding have been developed recently. As in parametric stereo a two-channel stereo audio signal is represented by means of a mono downmix audio signal and additional side information that carries stereo parameters (see PCT/SE02/01372 "Efficient and scalable Parametric Stereo Coding for Low Bitrate Audio Coding Applications"), a legacy parametric stereo decoder reconstructs a two-channel stereo signal from the mono signal and the side information.

[0010] In spatial audio coding schemes, a multi-channel surround audio signal is represented by means of a mono or stereo downmix audio signal and additional side information that carries spatial audio parameters. A widely known

example is the 5.1 channel configuration used for home entertainment systems.

[0011] A legacy spatial audio decoder reconstructs the 5.1 multi-channel signal based on the mono or stereo signal and the additional spatial audio parameters.

5 **[0012]** Typically downmix signals employed in parametric stereo or spatial audio coding systems are additionally encoded, using low bit rate perceptual audio coding techniques (like MPEG AAC) to further reduce the required transmission bandwidth for transmission of the different signal types. Furthermore the downmix signal is normally combined with the parametric stereo or with the spatial audio side information in a bitstream in a way, that assures backward compatibility with legacy decoders, that is with decoders that are not operative to process the parametric stereo or spatial audio parameters. In this way, a legacy audio decoder only reconstructs the mono or stereo downmix signal transmitted.

10 When a decoder implementing parametric stereo or spatial audio coding is used, the decoder will also recover the side information embedded in the bitstream and reconstruct the full two-channel stereo or 5.1 channel surround signal.

[0013] When spatial audio coding is used based on a mono downmix signal it is furthermore desirable to increase the backwards compatibility by providing a signal such that not only a legacy perceptual audio decoder can derive the mono downmix signal, but that additionally a parametric stereo decoding of such a bitstream is possible for a parametric stereo decoder that does not support spatial audio decoding. To achieve this goal, it is necessary to include both information, the parametric stereo side information and the spatial audio side information in the bitstream. This obvious approach leads to an undesirably high amount of side information within the bitstream. That would mean for a scenario where a total maximum bit rate has to be maintained to convey the mono signal and the side information, that an increase in side information would lead to less data rate available for the perceptually encoded mono downmix, which obviously reduces the audio quality of the decoded mono downmix signal.

20 **[0014]** Another prior art approach of simultaneously including both the parametric stereo and spatial audio parameters and the side information, requires a set of spatial audio parameters that are structured such, that a subset of these parameters permits to reconstruct a two-channel stereo signal from the mono downmix signal. This subset is embedded as parametric side information within the bitstream in a way compatible with parametric stereo bit streams, while remaining spatial audio parameters that do not belong to the subset are embedded as spatial audio side information in the bitstream compatible with spatial audio coders. On the decoder side, a decoder implementing only parametric stereo will reconstruct a two-channel stereo signal based on the subset of parameters that are embedded as parametric stereo side information. On the other hand, a decoder implementing spatial audio will recover the parametric stereo subset and the remaining spatial audio parameters. With this complete set of spatial parameters, the multi-channel signal can be reconstructed.

30 **[0015]** This approach, however, has the drawback that it compromises the audio quality of either the backward compatible parametric stereo reconstruction or the multi-channel reconstruction. This is evident, since in the first case, the subset of parameters that are also used as spatial audio parameters describe the interrelation between two channels of a 5.1 signal. The most natural choice would be the left-front (l) and the right-front (r) channel, which, however, can differ substantially from the correct values for the relationship of the left (l0) and right (r0) channels of a stereo downmix.

35 In the second case the correct values of a stereo downmix form said first subset, which means that they are used to describe an interrelation between the left-front and the right-front channel of a multi-channel surround signal. This, however, can lead to a significant imperfection of the spatial audio reconstruction due to quantization of the parameters, which is required, in order to embed them in the bitstream in a multi-channel compatible way.

40 **[0016]** It is the object of the present invention to provide a concept for creating and using a parametric representation of a multi-channel audio signal that allows for a more efficient representation hardly compromising neither the quality of a parametric stereo reconstruction nor the quality of a spatial audio reconstruction.

[0017] This object is achieved by a multi-channel audio decoder in accordance with claim 1 or an audio encoder in accordance with claim 11.

45 **[0018]** The present invention is based on the finding that a parametric representation of a multi-channel audio signal having parameters suited to be used together with a monophonic downmix signal can efficiently be derived in a backwards compatible way when a parameter combiner is used to generate the parametric representation by combining a set of spatial parameters and a stereo parameter resulting in a parametric representation having a decoder usable stereo parameter and an information on the set of spatial parameters that represents, together with the decoder usable stereo parameter, the set of spatial parameters.

50 **[0019]** By using an interrelation between the spatial parameters and the stereo parameters that are describing a stereo downmix of the same multi-channel audio signal also described by the spatial parameters, one can advantageously predict a subset of the spatial parameters based on the parametric stereo parameters.

55 **[0020]** Since the two-channel stereo signal described by the stereo parameters represents some form of a stereo-downmix of the 5.1 multi-channel signal, there are dependencies between the stereo parameters of the parametric stereo system and the spatial parameters of the spatial audio coding system, as mentioned above. The present invention uses these stereo parameters in combination with a subset of the spatial audio parameters to predict the values of the remaining spatial audio parameters not enclosed in said subset. Then, only the difference between the predicted and the actual values of the spatial audio parameters not in the subset needs to be conveyed. The entropy of this difference

(i.e. the prediction error) is typically less than the entropy of the actual parameter itself. This may be used by a system employing the present invention and some sort of subsequent entropy coding. Such a system requires less side information bit rate for the parametric stereo and spatial audio parameters than a system that would simply embed all parameters independently. It is to be noted that at the same time, such a system employing the present invention does

neither compromise the quality of the parametric stereo reconstruction nor the quality of the spatial audio reconstruction. **[0021]** As it is the goal to provide a parametric representation that is backwards compatible to parametric stereo decoders; it is preferred that the correct parameters representing the stereo-downmix should be used in order not to compromise the quality of the two-channel stereo signal reconstructed from a parametric stereo decoder. Nevertheless, in an alternative embodiment of the present invention, a small modification of the parametric stereo parameters is employed in the encoder, based on the estimated spatial parameters, in order to improve the performance of the parameter prediction for the spatial audio parameters. It is clear that this modification of the parametric stereo (PS) parameters leads, to a slightly reduced quality of the stereo signal reconstructed by a decoder only implementing parametric stereo decoding. By this embodiment of the present invention, the quality of the reconstructed spatial audio signal remains unaffected by the PS parameter modification, while the overall bit rate required for the PS and spatial side information embedded in a compatible bitstream is reduced.

[0022] In a preferred embodiment of the present invention, an encoder for deriving a parametric representation of a multi-channel audio signal is used that generates a bitstream, in which spatial audio parameters as well as parametric stereo parameters of a stereo downmix of the multi-channel signal are embedded in a fully backwards compatible way. That is, a parametric stereo decoder able to process parametric stereo parameters only, will be able to reconstruct a high quality stereo signal using the parametric stereo parameters. Furthermore, the inventive encoder replaces some of the spatial parameters by a differential representation of the actual spatial parameters and a prediction of the spatial parameter, whereas the prediction of the spatial parameter is based on the stereo parameters and on a set of the spatial audio parameters not replaced. Since both the spatial audio parameter representation as well as the parametric stereo representation parameters describe level differences and correlation between channel pairs, there is an interrelation between the spatial audio parameters and the stereo parameters, as both of them are derived from the same data basis, i.e. the multi-channel signal. Hence, by using the difference between the prediction and the real value for transmission, bit rate can be saved, since the differences normally have an entropy that is much smaller than the entropy of the underlying spatial audio parameter. When the prediction is perfect the difference of the prediction and the real value is obviously zero, which means that as representation of the replaced spatial parameters only zero values have to be transmitted or stored within the parametric representation, which is most advantageous when further entropy coding steps are performed on the representation, as it is usually the case.

[0023] By using the concept described above, an inventive encoder or decoder has the obvious advantage that despite the backwards compatible transmission of spatial audio and parametric stereo parameters without loss in precision, the bit rate can be decreased in comparison to a scenario, where the spatial audio parameters and parametric stereo parameters are simply transmitted independently within a bitstream.

[0024] In a further embodiment of the present invention, a small change is applied to the parametric stereo parameters prior to the prediction of the spatial parameters and the transmission of the altered spatial parameters. This has the great advantage that the stability of the prediction can be improved by the small change of the parametric stereo parameters and, hence, the overall bit rate can be further decreased. The cost is a small degradation in the quality of a stereo upmix reconstructed using the modified stereo parameters, since the actually optimal parametric stereo parameters are changed within the encoding process.

[0025] In a further embodiment of the present invention, an inventive audio encoder comprises a spatial downmixer to generate a monophonic signal from a multi-channel signal input into the encoder. The monophonic signal is further, compressed by an audio encoder, using e.g. perceptual audio compression, to further decrease the bit rate the monophonic downmix signal uses during transmission. A bitstream generator finally generates a bitstream to combine the mono signal, the spatial audio parameters and the parametric stereo parameters into a single, parametric stereo compatible bitstream.

[0026] In a further embodiment of the present invention, a parametric encoder or decoder comprises a control unit, allowing for a further decrease of the required bit rate. This is achieved by comparing the bit rate needed by the differential representation of the spatial parameters generated by using the difference of the actual spatial parameter and a prediction of the same with the bit rate needed for directly encoding the spatial parameters. Encoding is performed by means of a two-step encoding procedure, firstly comprising time and/or frequency differential encoding of each parameter individually, and a subsequent entropy encoding (using e.g. a Huffman encoder, an arithmetic encoder or a run-length encoder). This process exploits predictability (or redundancy) for each parameter based on its own history (as compared to prediction across parameter sets as described above). In the cases where the differential predictive encoding results in a higher bit rate, further bit rate can be saved by directly transmitting the spatial parameters for given time frames. The decision, which strategy was chosen, can either be transmitted within the bit stream to be processed on the decoder side or the decoder may decide without notification, which strategy had originally been used by applying appropriate

detection algorithms.

[0027] As already mentioned, a signal generated according to the present invention has the great advantage of being backwards compatible to a parametric stereo decoder and furthermore holding the information required for the reproduction of a full spatial (surround) signal when transmitted to an inventive decoder.

5 **[0028]** Therefore, an inventive decoder receiving the parametric stereo parameters and the spatial audio parameters can reconstruct a full set of spatial parameters by applying the same prediction and reverse transformation of the differentially transmitted spatial audio parameters to derive the full set of spatial audio parameters representing the spatial property of a multi-channel signal from an inventive bitstream.

10 **[0029]** In other words, the combination rule used to combine the parametric stereo parameters and the received spatial audio parameters to reconstruct a full set of spatial parameters is the inverse of the rule applied at an encoder side. In the case of differential encoding as mentioned above, this would mean, that first the prediction of the desired parameter is calculated using one or more of the parametric stereo parameters and one or more of the received spatial audio parameters. Then, the sum between the predicted value and the transmitted value is computed, this sum being the desired parameter of the full set of spatial parameters.

15 **[0030]** In a further embodiment of the present invention, an inventive decoder is able to also reconstruct a stereo representation of the multi-channel signal using the high quality parametric stereo parameters. This has the great advantage that an inventive decoder can be configured according to the needs, i.e. when only a stereo playback environment is available, a high quality stereo signal can be reproduced by an inventive decoder, whereas, when a multi-channel playback environment is at hand, the multi-channel representation of the signal may be reproduced to allow for the enjoyable listening to surround sound.

20 **[0031]** In a further embodiment of the present invention, an inventive encoder is comprised within a transmitter or audio recorder, allowing for bit rate saving storage or transmission of an audio signal, that may be reproduced with excellent quality either as a stereo signal or as full surround signal.

25 **[0032]** In a further embodiment of the present invention, an inventive decoder is comprised within a receiver or audio player, allowing to receive or playback signals using different loudspeaker setups, wherein the audio signal can be reproduced in the representation fitting the existing playback environment best.

[0033] Summarizing, the present invention comprises the following advantageous features:

- 30 - compatible coding of multi-channel audio signals, including,
 - at the encoder side, downmixing the multi-channel signal to a one channel representation,
 - at the encoder side given said multi-channel signal, definition of parameters representing the multi-channel signal,
 - at the encoder side given said multi-channel signal, definition of parameters representing a stereo downmix of the multi-channel signal,
 - at the encoder side, embedding both sets of parameters in a bitrate efficient and backward compatible manner in a bitstream,
 - 35 at the decoder side, extracting the embedded parameters from a bitstream,
 - at the decoder side, reconstructing parameters representing a multi-channel signal from the parameters extracted from the bitstream,
 - at the decoder side, reconstructing the multi-channel output signals given the parameters reconstructed from the bitstream data, and said downmixed signal;
- 40 - embedding the parameters representing a stereo downmix in the bitstream, such that they can be decoded by a (legacy) decoding method that only supports parametric stereo decoding;
- 45 - splitting the set of parameters representing the multi-channel signal in a first subset and a second subset;
- predicting of the values in said first subset of parameters based on said second subset of parameters and based on the parameters that represent a stereo downmix of the multi-channel signal;
- 50 - a controlling mechanism that automatically selects whether the first subset of parameters is encoded directly or whether only the differences relative to the predicted parameter values are encoded;
- modification of the parameters that represent a stereo downmix, where both the original parameters representing the multi-channel signal and the original parameters representing the stereo downmix are used as basis to derive the modified parameters;
- 55 - a look-up table being used to find said predicted parameter values;

- a polynomial function being used to find said predicted parameter values;
- a mathematical function derived from the method employed to generate the stereo downmix being used to find said predicted parameter values.

5
[0034] Preferred embodiments of the present invention are subsequently described by referring to the enclosed drawings, wherein

- 10
 Fig. 1 shows a block diagram of an inventive encoder;
- Fig. 2 shows a generated bitstream according to the present invention;
- Fig. 3 shows a further embodiment of an inventive encoder;
- 15
 Fig. 4 shows details of the inventive encoder of Fig. 3;
- Fig. 5 shows an inventive decoder;
- Fig. 6 shows a preferred embodiment of an inventive multi-channel decoder;
- 20
 Fig. 7 shows details of the inventive multi-channel decoder of Fig. 6;
- Fig. 8 illustrates the backwards compatibility of an inventive signal;
- 25
 Fig. 9 shows a transmitter or audio recorder having an inventive encoder;
- Fig. 10 shows a receiver or audio player having an inventive multi-channel decoder; and
- 30
 Fig. 11 shows a transmission system.

[0035] The below-described embodiments are merely illustrative for the principles of the present invention for improved parametric stereo compatible coding of spatial audio. It is understood that modifications and variations of the arrangements and the details described herein will be apparent to others skilled in the art. It is the intent, therefore, to be limited only by the scope of the impending patent claims and not by the specific details presented by way of description and explanation of the embodiments herein.

35
[0036] Fig. 1 shows an inventive encoder 10 for deriving a parametric representation 12 of a multi-channel audio signal. The encoder 10 is comprising a spatial parameter calculator 14, a stereo parameter calculator 16 and a parameter combiner 18.

40
[0037] The spatial parameter calculator 14 calculates a set of spatial parameters 20 describing the spatial properties of a multi-channel signal. The stereo parameter calculator 16 is calculating stereo parameters 22 describing spatial properties of a stereo downmix of the multi-channel signal. The set of spatial parameters 20 and the stereo parameters 22 are transferred to the parameter combiner 18 that is deriving the parametric representation 12, which comprises a decoder usable stereo parameter 24 and an information on the set of spatial parameters 26.

45
[0038] Fig. 2 is showing an example for a backwards compatible bitstream being the parametric representation of a multi-channel audio signal as produced by an inventive encoder according to Fig. 1. The bitstream is comprising a stereo parameter section 30 and a spatial parameter section 32. The stereo parameter section 30 is having a stereo header 34 at the beginning of the stereo parameter section 30, followed by two decoder usable stereo parameters 36a and 36b, that would be used by a parametric stereo decoder to reconstruct the stereo signal. A decoder being able to process parametric stereo parameters only would identify the parametric stereo parameters 36a and 36b by the information comprised in the stereo header 34.

50
[0039] The spatial audio section 32 begins with a spatial header 38 and comprises four spatial audio parameters 40a to 40d. A multi-channel decoder according to the present invention would use the spatial parameters 40a to 40d by identifying them with the help of the spatial header 38 as well as the stereo parameters 36a and 36b as identified by the stereo header 34. As indicated in Fig. 2, the spatial parameter 40a consumes less bitrate than the spatial parameters 40b to 40d. In the example shown in Fig. 2, the spatial parameter 40a is represented by the difference of the underlying original spatial parameter, and a predicted spatial parameter derived using one or more of the stereo parameters 36a or 36b and one or more of the spatial audio parameters 40b to 40d. An inventive multi-channel decoder would therefore need to use both the stereo parameters 36a and 36b and the spatial parameters 40b to 40d to reconstruct the spatial

parameter underlying the information on the spatial parameter 40a that is transmitted in the bitstream.

[0040] Fig. 3 is showing a preferred embodiment of an inventive encoder 52 for deriving a parametric representation of a multi-channel audio signal 50, that is having three channels, a left channel l, a right channel r and a center channel c.

[0041] The inventive encoder 52 is comprising a spatial downmixer 54, a spatial parameter estimator 56, a stereo downmixer 58, a parametric stereo parameter estimator 60, an audio encoder 62, a parameter combiner (joint encoding block) 64 and a bitstream calculator (multiplexer) 66.

[0042] The spatial downmixer 54, the spatial parameter estimator 56 and the stereo downmixer 58 receive as an input the multi-channel signal 50. The spatial downmixer 54 creates a monophonic downmix signal 68 from the multi-channel signal 50, the spatial parameter estimator 56 derives spatial parameters 70 describing spatial properties of the multi-channel signal, and the stereo downmixer 58 creates a stereo downmix signal 72 from the multi-channel signal 50.

[0043] The stereo downmix signal 72 is input to the parametric stereo parameter estimator 60, which derives stereo parameters 74 from the stereo downmix signal describing spatial properties of the stereo downmix signal 72. The monophonic downmix signal 68 is input into the audio encoder 62 that derives an audio bitstream 76 representing the monophonic downmix signal 68 by means of encoding, using for example perceptual audio encoding techniques. The parameter combiner 64 receives as an input the spatial parameters 70 as well as the parametric stereo parameters 74 and derives as an output decoder usable stereo parameters (parametric stereo side information) 78 and information on the spatial parameters (spatial side info) 80 by replacing sets of spatial parameters by the difference of a prediction of the spatial parameters and the spatial parameters themselves. This will be described in more detail by the following Figure.

[0044] The bitstream calculator 66 finally receives as an input the audio bitstream 76, the information on the set of spatial parameters 80 and the decoder usable stereo parameters 78 and combines said input into a parametric stereo compatible bitstream 82, that could for example comprise segments of parameters as detailed in Fig. 2.

[0045] The bit stream calculator 66 can be a simple multiplexer. Nonetheless other means to combine the three inputs into a compatible bitstream may also be implemented to derive a bitstream according to the present invention.

[0046] In other words, Figure 3 illustrates an encoder that takes a multi-channel audio signal, comprising the channels l, r, and c, as input and generates a compatible bitstream that permits decoding by a spatial decoder as well as backward-compatible decoding by a PS decoder. The spatial downmix takes the multi-channel signal l, r, c and generates a mono downmix signal m. This signal can then be encoded by an optional perceptual audio encoder to produce a compact audio bitstream representing the mono signal. The spatial parameter estimation takes the multi-channel signal l, r, c as input and generates a set of quantized spatial parameters. These parameters can be a function of time and frequency. The downmix to stereo produces a 2-channel stereo downmix l, r of the multi-channel signal, for example using the ITU-R downmix equations or alternative approaches. The parametric stereo (PS) parameter estimation takes this stereo downmix as input and generates a set of quantized PS parameters, which can be a function of time and frequency. The joint encoding block takes both the spatial parameter and the PS parameter as input and produces the parametric stereo side information (PS side info) and the spatial side info. Finally a multiplexer takes the audio bitstream and both the spatial and PS side info bitstreams as input and embeds the side information in such a way in the bitstream that backward compatible decoding by legacy decoder (only implementing PS) is possible.

[0047] Fig. 4 details the parameter combiner 64 shown in Fig. 3. The parameter combiner 64 is having a parameter splitter 90, a parametric stereo parameter modifier 92, a spatial parameter predictor 94, a combiner 96, a control unit 98, a spatial parameter assembler 100 and a first differential encoder 102, a second differential encoder 104, a third differential encoder 106a and a fourth differential encoder 106b.

[0048] The parameter combiner 64 receives as input the spatial parameters 70 and the parametric stereo parameters 74. The parametric stereo parameters 74 are input into the parametric stereo parameter modifier 92 at a first input of the same, and the spatial parameters 70 are input into the parametric stereo parameter modifier 92 at a second input.

[0049] The spatial parameters 70 are furthermore input into the parameter splitter 90. The parametric stereo parameter modifier 92 is an optional device, that may be used to derive decoder usable stereo parameters 110 by modifying the parametric stereo parameters 74 using information of the spatial parameters 70.

[0050] The parameter splitter 90 divides the spatial parameters 70 into a first subset 112 of the spatial parameters and into a second subset 114 of the spatial parameters, wherein the first subset 112 is the subset of the spatial parameters that may be replaced by a differential prediction within the final parametric representation of the multi-channel signal.

[0051] As the prediction of the parameters within the first subset is performed using the decoder usable stereo parameters 110 and the second subset 114 of the spatial parameters both the decoder usable parameters 110 and the second subset of spatial parameters 114 are input into the spatial parameter predictor 94. The spatial parameter predictor 94 is deriving predicted parameters 116 using the decoder usable parametric stereo parameters 110 and the second subset of the spatial parameters 114. The predicted parameters 116 are a prediction of the parameters of the first subset 112 and are to be compared with the parameters of the first subset 112.

[0052] Therefore, the difference of the predicted parameters 116 and the first subset of parameters 112 is computed parameter-wise by the combiner 96, that is such deriving difference parameters 118. The first subset of parameters 112 is input into the third differential encoder 106a that differentially encodes the first subset of parameters either by applying

differential encoding in time or in frequency. The differential parameters 118 are input into the fourth differential encoder 106b.

[0053] According to the preferred embodiment of the present invention shown in Fig. 4, the differentially encoded representation of the first subset 112 is compared to the differentially encoded representation of the differential parameters 118 by the control unit 98 to estimate, which representation requires more bits within a bitstream. The control unit 98 controls a switch 120, to supply that representation of the first subset 112 to the spatial parameter assembler 100 that requires less bits, whereas the information which representation was used is additionally transferred from the control unit 98 to the spatial parameter assembler 100.

[0054] The second subset 114 of the spatial parameters is also differentially encoded by the second differential encoder 104, and the differentially encoded representation of the second subset 114 is input into the spatial parameters assembler 100, that is such having the full information on the spatial parameters 70. The spatial parameter assembler 100 finally derives the information on the spatial parameters 80 by reassembling the representations of the first subset 112 and the second subset 114 into the information on the set of spatial parameters 80 that is holding the full information on the spatial parameters 70.

[0055] The final information on the set of spatial parameters 80 is, therefore comprising a second subset of spatial parameters that are unmodified despite a differential encoding of the same and a representation of the first subset of spatial parameters, that may either be the differentially encoded representation of the first subset 112 directly or a differentially encoded representation of differential parameters 118, depending on which representation requires less bit rates.

[0056] The decoder usable parametric stereo parameters 78 that are derived by an inventive parameter combiner 64, are derived by the first differential encoder 102. The first differential encoder 102 receives as an input the modified parametric stereo parameters 110 and derives the decoder usable parametric stereo parameters 78 by differentially encoding the modified parametric stereo parameters 110.

[0057] In other words, Figure 4 illustrates the joint encoding block which takes both the spatial parameter and the PS parameter as input and generates both the spatial side info and the PS side info. An optional PS parameter modification block takes both the spatial parameter and the PS parameter as input and generates modified PS parameter. This permits to achieve better prediction of spatial parameter at the cost of compromising the quality of the 2-channel stereo signal reconstructed from the modified PS parameter. If the PS parameter modification block is not employed, the incoming PS parameter directly serve as input to the spatial parameter prediction block and to the PS encoding. The (modified) PS parameter set can be encoded using time-differential (dt) or frequency-differential (df) encoding, i.e., coding of differences of subsequent parameters in time or frequency direction respectively, and Huffman encoding, i.e., lossless entropy coding, in order to minimize the number of bits required to represent the parameter set. The parameter split block separates the set of spatial parameter in a second subset that is encoded directly and a complementary first subset that contains all remaining parameters and which can be encoded utilizing parameter prediction. The spatial parameter prediction block takes the second subset of the spatial parameter and the (modified) PS parameter as input and calculates predicted values for the first subset of the spatial parameter. These predicted values are then subtracted from the actual values of the spatial parameters in the first subset, resulting in a set of prediction error values.

[0058] The second parameter subset can be encoded using time or frequency-differential encoding and Huffman encoding in order to minimize the number of bits required to represent the parameter subset. The first parameter subset can be encoded using time or frequency-differential encoding and Huffman encoding in order to minimize the number of bits required to represent the parameter subset. The prediction error values for the first parameter subset can be encoded using time or frequency-differential encoding and Huffman encoding in order to minimize the number of bits required to represent the parameter subset. A control block selects either whether first parameter subset should be encoded directly or whether the prediction error should be encoded in order to minimize the number of bits required to represent the first parameter subset. This selection can be done individually for each parameter in the subset. The actual selection decision can either be conveyed as side information in the bitstream or can be based on rules that are part of the spatial parameter prediction. In the latter case, this decision does not have to be conveyed as side information. Finally, a multiplexer combines all encoded data to form the spatial side info.

[0059] To use the inventive concept of encoding or decoding, different implementations of the prediction of the parameters are feasible. Generally, one has the possibility to use an appropriately designed look-up table to derive a prediction of the first subset of the spatial parameters from the stereo parameters and the second subset of the spatial parameters or one could alternatively apply an analytic function to derive the predicted parameters based on the knowledge of the specific downmix processes and the ways the spatial parameters and the stereo parameters are derived. The following paragraphs give an overview of some specific examples of achieving an appropriate prediction.

[0060] This overview is based on a multi-channel signal having three channels,

- l: Left,
- c: Center,

- r: Right,

which is to be considered as an example only. The presented principles obviously apply correspondingly also to other channel configurations. For example, in case of a 5.1 channel configuration, the Left Front and Left Surround channel can be combined using a parametric stereo module to form the left signal (l), the Right Front and Right Surround channel can be combined using a parametric stereo module to form the right signal (r), and the Center Front and Low Frequency Enhancement channel can be combined using a parametric stereo module to form the center signal (c).

[0061] The following description discusses the spatial parameter prediction block in more detail. The 2 channels of the stereo downmix signal are denoted:

l_0 : Left Downmix,
 r_0 : Right Downmix,

and the mono downmix is denoted

m: Mono Downmix.

[0062] The prediction block outputs predicted values $\hat{s}_1, \dots, \hat{s}_K$ of the first K quantized spatial parameters s_1, \dots, s_K (i.e., a first subset of the spatial parameters), given the quantized modified or unmodified PS parameters p_1, p_2 and a second subset $s_{K+1}, s_{K+2}, \dots, s_N$ of the remaining quantized spatial parameters.

[0063] In the most general sense, it consists of a tabulated function (look-up table)

$$(\hat{s}_1, \dots, \hat{s}_K) = F(p_1, p_2, s_{K+1}, s_{K+2}, \dots, s_N) \quad (1)$$

[0064] The difference signal is then equal to the prediction error

$$(d_1, \dots, d_K) = (s_1 - \hat{s}_1, \dots, s_K - \hat{s}_K) \quad (2)$$

[0065] A first design method is to let F be a tabulated function or a multivariate polynomial chosen so as to minimize the prediction error in the least squares sense over a large database of parameters. Alternatively, F can be chosen so as to minimize the resulting bitrate required to represent the first subset of spatial parameters, where a large database of parameters is used as training data to find the optimal F in this sense. Before use in the prediction unit, such a tabulated function or polynomial can be followed by a rounding or quantization operation in order to produce integer results.

[0066] An important special case of this is the use of a linear prediction where F is a polynomial of degree one.

[0067] A second class of predictor designs are those that take into account the actual parameter structure used. In the preferred embodiment of the invention, $K=2$ and $N=4$, and the parameters convey information according to:

p_1 : iid_l0_r0 Interchannel intensity difference (IID) between channels l_0 and r_0 ;
 p_2 : icc_l0_r0 Interchannel coherence or cross-correlation (ICC) between channels l_0 and r_0 ;
 s_1 : iid_l_r Interchannel intensity difference (IID) between channels l and r ;
 s_2 : icc_l_r Interchannel coherence or cross-correlation (ICC) between channels l and r ;
 s_3 : iid_lr_c Interchannel intensity difference (IID) between channels $l+r$ and c ;
 s_4 : icc_lr_c Interchannel coherence or cross-correlation (ICC) between channels $l+r$ and c .

[0068] The first example of such a design is a special case of the linear predictor design above and consists of simply putting

$$\hat{s}_1 = p_1, \quad \hat{s}_2 = p_2. \quad (3)$$

[0069] This simple predictor has the advantage that it result in a more stable prediction error (rather than a minimal prediction error) which is well suited for the time-differential or frequency-differential coding of said prediction error. This is true for all predictors like polynomials mentioned above.

[0070] The second example is based on the assumption that the stereo downmix is produced by

$$l_0 = l + q \cdot c, \quad r_0 = r + q \cdot c, \quad (4)$$

with a known center channel gain q , (typically 1 or $1/\sqrt{2}$). All signals l, r, c are finite length vectors typically resulting from a time and frequency interval of subband samples from a complex modulated filter bank analysis of time signals. For complex vectors x, y , the complex inner product and squared norm is defined by

$$\left\{ \begin{array}{l} \langle x, y \rangle = \sum_n x(n) y^*(n), \\ X = \|x\|^2 = \langle x, x \rangle = \sum_n |x(n)|^2, \\ Y = \|y\|^2 = \langle y, y \rangle = \sum_n |y(n)|^2, \end{array} \right. \quad (5)$$

where the star denotes complex conjugation. The linear and non-quantized versions of the IID parameters are then assumed to be obtained by

$$P_1 = \sqrt{\frac{L_0}{R_0}}, \quad S_1 = \sqrt{\frac{L}{R}}, \quad S_3 = \sqrt{\frac{L+R}{C}}. \quad (6)$$

[0071] For the ICC parameters, in the case of cross-correlation, the formulas are

$$P_2 = \frac{\text{Re}\langle l_0, r_0 \rangle}{\sqrt{L_0 \cdot R_0}}, \quad S_2 = \frac{\text{Re}\langle l, r \rangle}{\sqrt{L \cdot R}}, \quad S_4 = \frac{\text{Re}\langle l+r, c \rangle}{\|l+r\| \cdot \|c\|}. \quad (7)$$

[0072] In the case of coherence, the real value operations are replaced with absolute value (complex magnitude) operations in the formulas (7).

[0073] Assuming for simplicity that $\langle l, c \rangle = \langle r, c \rangle = 0$, it follows that $L_0 = L + q^2 C$ and $R_0 = R + q^2 C$ which can be inserted in the first formula of (6). By solving two equations with two unknowns, the following estimates of $X=L/C$ and $Y=R/C$ from P_1 and S_3 are then obtained,

$$\hat{X} = \frac{P_1^2 S_3^2 + q^2 (P_1^2 - 1)}{P_1^2 + 1}, \quad \hat{Y} = \frac{S_3^2 - q^2 (P_1^2 - 1)}{P_1^2 + 1} \quad (8)$$

[0074] When both values in formula (8) are positive, the estimate of S_1 is formed as $\hat{S}_1 = \sqrt{\hat{X}/\hat{Y}}$. Here, the required linear parameter values are obtained by dequantizing the given integer parameters and the integer parameter estimate \hat{S}_1 is then obtained by quantization of \hat{S}_1 .

[0075] When a slightly compromised quality of the decoded stereo signal is acceptable, the overall bitrate can be

reduced further by employing modification of the parametric stereo parameters. The purpose of this modification is to achieve more stable prediction of the first subset of spatial parameters and reduced prediction error. It can be seen as a means to stabilize above computations. The most extreme case of such a parameter modification would be to use $p_1'=s_1$, $p_2'=s_2$ where p_1' , p_2' denote the modified parametric stereo parameters. Since this parameter modification operation is carried out only at the encoder side, no special care needs to be taken on the decoder side.

[0076] A more general approach incorporates the complete power and correlation structure information available in P_1, P_2, S_3, S_4 via formulas (6) and (7) to obtain estimates of S_1 and S_2 . By the scaling invariance of parameters, there is no loss of generality in assuming for computational purposes that $C=1$. Then with the definitions

$$a = \text{Re}\langle l, c \rangle, \quad b = \text{Re}\langle r, c \rangle, \quad \rho = \text{Re}\langle l, r \rangle, \quad (9)$$

the following system of equations arises:

$$\left\{ \begin{array}{l} L + q^2 + 2qa = P_1^2(R + q^2 + 2qb) \\ \rho + q^2 + 2q(a + b) = P_2(L + q^2 + 2qa)^{1/2}(R + q^2 + 2qb)^{1/2} \\ L + R = S_3^2 \\ a + b = S_4(L + R + 2\rho)^{1/2}. \end{array} \right. \quad (10)$$

[0077] The unknowns of interest for estimation are L, R, ρ and a, b are additional unknowns. This (underdetermined) system of equation can be used as guidance for a multitude of prediction formulas, depending on the selection of restrictions on the pair a, b . For instance, the first and third equation of (10) imply

$$\left\{ \begin{array}{l} (1 + P_1^2)L = q^2(P_1^2 - 1) + 2q(P_1^2b - a) + P_1^2S_3^2 \\ (1 + P_1^2)R = S_3^2 - q^2(P_1^2 - 1) - 2q(P_1^2b - a) \end{array} \right. \quad (11)$$

so the computations that lead to formulas (8) corresponds to the case where $P_1^2b=a$. More generally, a heuristic parameter γ defines a restriction on the pair a, b via $\gamma=P_1^2b-a$.

[0078] It is again emphasized that the above prediction schemes are only examples for possible prediction schemes that can be implemented as well on an encoder side as on a decoder side.

[0079] Fig. 5 shows an inventive multi-channel audio decoder 200 for processing a parametric representation 202.

[0080] The parametric representation 202 is comprising information on a set of spatial parameters 204 describing the spatial properties of a multi-channel signal and decoder usable stereo parameters 206 describing spatial properties of a stereo downmix of the multi-channel signal. The inventive multi-channel audio decoder 200 is having a parameter reconstructor 208 for combining the decoder usable stereo parameters 206 and the information on the set of spatial parameters to obtain spatial parameters 210.

[0081] Fig. 6 shows an embodiment of a multi-channel audio decoder 220 according to the present invention. The multi-channel audio decoder 220 is having a bitstream decomposer (demultiplexer) 222, an audio decoder 224, a parameter reconstructor (joint decoder) 226 and an upmixer 228.

[0082] The bitstream decomposer 222 receives a backwards compatible bitstream 230 comprising an audio bitstream 231, information on a set of spatial parameters 232 and decoder usable stereo parameters (PS side info) 234. The bitstream decomposer decomposes or demultiplexes the backwards compatible bitstream 230 to derive the audio bitstream 231, the information on the set of spatial parameters 232 and the decoder usable stereo parameters 234. The audio decoder 224 receives the audio bitstream 231 as input and derives a monophonic downmix signal 236 from the audio bitstream 231.

[0083] The parameter reconstructor 226 receives the information on the set of spatial parameters 232 and the decoder usable stereo parameters 234 as an input. The parameter reconstructor 226 combines the information on the set of spatial parameters and the decoder usable stereo parameters to derive a set of spatial parameters 238 that serves as an input to the upmixer 228, which further receives the monophonic downmix signal 236 as second input. Based on the spatial parameters 238 and on the monophonic downmix signal 236, the upmixer 228 derives a reconstruction of a multi-

channel signal 240 at its output.

[0084] Figure 6 therefore illustrates a spatial audio decoder that takes a compatible bitstream as input and generates the multi-channel audio signal, comprising the channels 1, r, and c. First a demultiplexer takes the compatible bitstream as input and decomposes it into an audio bitstream and both the spatial and PS side info. If perceptual audio coding was applied to the mono signal, a corresponding audio decoder takes the audio bitstream as input and generates the decoded mono audio signal m, subject to distortion as introduced by the perceptual audio codec. The joint decoding block takes both the spatial and PS side info as input and reconstructs the spatial parameters. Finally the spatial reconstruction takes the decoded mono signal m and the spatial parameters as input and reconstructs the multi-channel audio signal.

[0085] Fig. 7 gives a detailed description of the parameter reconstructor 226 used by the multi-channel audio decoder 220. The parameter reconstructor 226 is comprising a spatial parameter disassembler 250, a control unit 252, a spatial parameter predictor 254, a spatial parameter assembler 256 and a first differential decoder 258, a second differential decoder 260, a third differential encoder 262a, and a fourth differential decoder 262b.

[0086] The spatial parameter disassembler 250 receives the information on the set of spatial parameters 232 as an input and derives a first subset 266 and a second subset 268 from the information on the set of spatial audio parameters 232. The first subset 266 comprises the parameters that are possibly being represented by a predictive differential representation performed on the encoder side, and the second subset 268 comprises a subset of the information on the set of spatial parameters that is transmitted unmodified within the bitstream.

[0087] Furthermore, the control unit 252 optionally receives control information from the spatial parameter disassembler, indicating whether a predictive differential representation had been used during encoding or not. This information is optional in the sense that the control unit 252 could alternatively derive, using appropriate algorithms, whether such a prediction had been performed or not without having access to an indicating parameter.

[0088] The second subset of parameters 268 is input into the second differential decoder 260, that differentially decodes the second subset to derive a second subset of spatial parameters 270.

[0089] The first differential decoder 258 receives as an input the decoder usable stereo parameters 234, to derive parametric stereo parameters 272 from the encoded representation. The spatial parameter predictor 254 is operating in the same way as its counterpart on the encoder side, therefore it receives as a first input the parametric stereo parameters 272 and as a second input the second subset of spatial parameters 270 to derive predicted parameters 274.

[0090] The control unit 252 controls two possible different data paths for the first subset of the information on the set of spatial parameters. When the control unit 252 indicates that the first subset of the information of the set of spatial parameters had not been transmitted using predictive differential coding, the control unit 252 steers switches 278a and 278b such, that the first subset 266 is input into the third differential decoder 262a to derive a first subset of the set of spatial parameters 280 without applying inverse prediction. The first subset of spatial parameters 280 is then input into the spatial parameter assembler 256 at a second input of the same.

[0091] If, however, the control unit 252 indicates differentially predicted parameters, the first subset 266 of the information of the set of spatial parameters is input into the fourth differential decoder 262b to derive a differentially predicted representation of the first subset 266 at an output 282 of the differential decoder. Then, the sum of the differential representation and the predicted parameters 274 is computed by an adder 284, thus reversing the differential prediction operation performed on an encoder side. As a result, the first set of spatial parameters 280 is available at the second input of the spatial parameter assembler 256. The spatial parameter assembler 256 combines the first set of spatial parameters 280 and the second set of spatial parameters 270 to provide a full set of spatial parameters 290 at its output, which is the basis of a multi-channel reconstruction of an encoded signal.

[0092] Summarizing, Figure 7 illustrates the joint decoding block which takes both the spatial side info and the PS side info as input and reconstructs the spatial parameter. A demultiplexer separates the spatial side info in an encoded second subset of spatial parameter and encoded first subset of spatial parameter and control information. The decoding block takes the encoded second subset of spatial parameter as input and reconstructs this parameter subset. This includes Huffman decoding and time-differential (dt) or frequency-differential (df) decoding in case such coding was employed in the encoder. The decoding block takes the PS side info as input and reconstructs the (modified) PS parameter. The spatial parameter prediction block takes the second subset of the spatial parameter and the (modified) PS parameter as input and calculates predicted values for the first subset of the spatial parameter in the same way as done by its counterpart in the encoder. The control block determines which selection decision was taken by its counterpart, the control block in the encoder. Depending on this selection, the encoded first subset of spatial parameter is either decoded directly or decoded taken into account the prediction. In both cases, this includes Huffman decoding and time or frequency-differential decoding in case such coding was employed in the encoder. In case the control block determined that no prediction was used, the output of decoding block is taken as the reconstructed first subset of spatial parameter. Otherwise, the output of decoding block contains the prediction error values which are then added to the predicted parameter values as generated by the spatial parameter prediction in order to obtain the original values of the first subset of spatial parameters. Finally the reconstructed first and second subset of spatial parameters are merged to form the

full set of spatial parameters.

[0093] Fig. 8 illustrates, how a compatible inventive bitstream is processed by a legacy parametric stereo decoder to derive a stereo upmix of a signal to emphasize the great advantage of the full backwards compatibility of the inventive concept.

5 **[0094]** A parametric stereo decoder 300 is receiving a compatible bitstream 302 as input. The parametric stereo decoder 300 is comprising a demultiplexer 304, an audio decoder 306, a differential decoder 308 and an upmixer 310. The demultiplexer 304 derives an audio bitstream 312 and decoder usable parametric stereo parameters 314 from the compatible bitstream 302.

10 **[0095]** As the parametric stereo decoder 300 cannot operate on spatial audio parameters, the demultiplexer 304 simply neglects the spatial audio parameters comprised within the compatible bitstream 302, for example by skipping header fields and associated data sections within the bitstream not known to the decoder. The audio bitstream 312 is input into the audio decoder 306 that derives a monophonic downmix signal 316 whereas the decoder usable stereo parameters 314 are differentially decoded by the differential decoder 308 to derive parametric stereo parameters 318. The monophonic downmix signal 316 and the parametric stereo parameters 318 are input into the upmixer 310, that derives a stereo upmix signal 320 using the monophonic downmix signal 316 and the parametric stereo parameters 318.

15 **[0096]** In other words, Figure 8 illustrates a parametric stereo (PS) decoder that takes a compatible bitstream as input and generates a 2-channel stereo audio signal, comprising the channels 10 and r0. First a demultiplexer takes the compatible bitstream as input and decomposes it into an audio bitstream and the PS side info. Since the spatial side info was embedded in the compatible bitstream in a backward compatible manner, it does not affect the demultiplexer. 20 If perceptual audio coding was applied to the mono signal, a corresponding audio decoder takes the audio bitstream as input and generates the decoded mono audio signal m, subject to distortion as introduced by the perceptual audio codec. The PS decoding block takes the PS side info as input and reconstructs the PS parameter. This includes Huffman decoding and time-differential (dt) or frequency-differential (df) decoding in case such coding was employed in the encoder. Finally the PS reconstruction takes the decoded mono signal m and the PS parameters as input and reconstructs 25 the 2-channel stereo signal.

[0097] Fig. 9 is showing an inventive audio transmitter or recorder 330 that is having an audio encoder 10, an input interface 332 and an output interface 334.

30 **[0098]** An audio signal can be supplied at the input interface 332 of the transmitter/recorder 330. The audio signal is encoded by an inventive encoder 10 within the transmitter/recorder and the encoded representation is output at the output interface 334 of the transmitter/recorder 330. The encoded representation may then be transmitted or stored on a storage medium.

[0099] Fig. 10 shows an inventive receiver or audio player 340, having an inventive audio decoder 180, a bit stream input 342, and an audio output 344.

35 **[0100]** A bit stream can be input at the input 342 of the inventive receiver/audio player 340. The bit stream then is decoded by the decoder 180 and the decoded signal is output or played at the output 344 of the inventive receiver/audio player 340.

[0101] Fig. 11 shows a transmission system comprising an inventive transmitter 330, and an inventive receiver 340.

40 **[0102]** The audio signal input at the input interface 332 of the transmitter 330 is encoded and transferred from the output 334 of the transmitter 330 to the input 342 of the receiver 340. The receiver decodes the audio signal and plays back or outputs the audio signal on its output 344.

45 **[0103]** Summarizing the inventive concept, one can say, that the present invention relates to coding of multi-channel representations of audio signals using spatial audio parameters in a manner that is compatible with coding of 2-channel stereo signals using parametric stereo parameters. The present invention teaches new methods for efficient coding of both spatial audio parameters and parametric stereo parameters and for embedding the coded parameters in a bitstream in a backward compatible manner. In particular it aims at minimizing the overall bitrate for the parametric stereo and spatial audio parameters in backward compatible bitstream without compromising the quality of the decoded stereo or multi-channel audio signal. However, when a slightly compromised quality of the decoded stereo signal is acceptable, the overall bitrate can be reduced further.

50 **[0104]** Although the bitstreams describing the backwards compatibility of the inventive signal and the generation of the same do not comprise parameters describing the monophonic downmix signal, it goes without saying that such parameters can be easily incorporated into the bitstream shown.

55 **[0105]** Arbitrary numbers of the spatial audio parameters can be predicted by using parametric stereo parameters if one is able to derive an appropriate rule to predict the parameters. Therefore, the detailed prediction rules given above are to be understood as examples only. It is clear that other prediction rules can lead to the same bit saving effect and, therefore, the present invention is by no means limited to using one of the prediction rules described above.

[0106] Although a parametric stereo downmixer 58 which derives a stereo downmix of a multi-channel signal does exist in the examples of inventive encoders given, in practical implementations, the stereo downmixer can be omitted, if the downmixing rule is known, and when, therefore, the parametric stereo parameters can be derived from the multi-

channel signal directly.

[0107] In the given implementations, the monophonic downmix signal is further encoded by an audio encoder or decoded on a decoder side. The encoding and decoding is optional, i.e. omitting a further compression of the monophonic downmix signal will also yield inventive encoders and decoders incorporating the inventive concept.

5 **[0108]** The control unit within the inventive encoders and decoders may be omitted and one may go for a general decision to represent subsets of spatial parameters by differential predicted parameters at the benefit of saving the control unit and at the cost of accepting a slightly higher bit rate for the rare cases, when the differential predicted representation does not save transmission bit rate.

10 **[0109]** Although, within the given examples, additional encoders applied in the signal paths are referred to as differential encoders or differential decoders only, it is understood, that any other appropriate encoder or decoder suited to compress the parameters may also be used, especially a combination of a differential de- or encoder and a Huffman de- or encoder. Such a combination is used in a way, that firstly the parameters are differentially encoded and then the differentially encoded parameters are Huffman encoded, which finally results in a parametric representation using smaller bit rates, since the differentially predicted representation in general has lower entropy than the spatial parameters underlying themselves.

15 **[0110]** Summarizing the inventive ideas, the present invention teaches the following:

[0111] In a first aspect a method for compatible coding of multi-channel audio signals, characterized by: at the encoder side, downmixing the multi-channel signal to a one channel representation; at the encoder side given said multi-channel signal, define parameters representing the multi-channel signal; at the encoder side given said multi-channel signal, define parameters representing a stereo downmix of the multi-channel signal; at the encoder side, embed both sets of parameters in a bitrate efficient and backward compatible manner in a bitstream; at the decoder side, extract the embedded parameters from a bitstream; at the decoder side, reconstruct parameters representing a multi-channel signal from the parameters extracted from the bitstream; at the decoder side, reconstruct the multi-channel output signals given the parameters reconstructed from the bitstream data, and said downmixed signal.

20 **[0112]** As a second aspect a method according to the first aspect, characterized by embedding the parameters representing a stereo downmix in the bitstream, such that they can be decoded by a (legacy) decoding method that only supports parametric stereo decoding.

25 **[0113]** As a third aspect a method according to the first aspect, characterized by splitting the set of parameters representing the multi-channel signal in a first subset and a second subset.

30 **[0114]** As a fourth aspect a method according to the third aspect, characterized by a prediction of the values in said first subset of parameters based on said second subset of parameters and based on the parameters that represent a stereo downmix of the multi-channel signal.

35 **[0115]** As a fifth aspect a method according to the fourth aspect, characterized by a control method that automatically selects whether the first subset of parameters is encoded directly or whether only the differences relative to the predicted parameter values are encoded.

[0116] As a sixth aspect a method according to the third aspect, characterized by modification of the parameters that present a stereo downmix, where both the original parameters representing the multi-channel signal and the original parameters representing the stereo downmix are used as basis to derive the modified parameters.

40 **[0117]** As a seventh aspect a method according to the fourth aspect, characterized by a look-up table being used to find said predicted parameter values.

[0118] As an eight aspect a method according to the fourth aspect, where in the fourth aspect polynomial function is being used to find said predicted parameter values.

[0119] As a ninth aspect a method according to the fourth aspect, characterized by mathematical function derived from the method employed to generate the stereo downmix being used to find said predicted parameter values.

45 **[0120]** As a tenth aspect an apparatus for encoding a representation of a multi-channel audio signal, characterized by: means for downmixing the multi-channel signal to a one channel representation; means for defining parameters representing the multi-channel signal; means for defining parameters representing a stereo downmix of the multi-channel signal; means for embedding both sets of parameters in a bitrate efficient and backward compatible manner in a bitstream.

50 **[0121]** As an eleventh aspect an apparatus for reconstructing a multi-channel signal based on a down-mixed signal and corresponding parameter sets, characterized by: means for extracting the parameter sets embedded in a bitstream; means for reconstructing parameters representing a multi-channel signal from the parameters extracted from the bitstream; means for reconstructing the multi-channel output signal given the parameter set reconstructed from the bitstream data, and said downmixed signal.

55 **[0122]** Depending on certain implementation requirements of the inventive methods, the inventive methods can be implemented in hardware or in software. The implementation can be performed using a digital storage medium, in particular a disk, DVD or a CD having electronically readable control signals stored thereon, which cooperate with a programmable computer system such that the inventive methods are performed. Generally, the present invention is, therefore, a computer program product with a program code stored on a machine readable carrier, the program code

being operative for performing the inventive methods when the computer program product runs on a computer. In other words, the inventive methods are, therefore, a computer program having a program code for performing at least one of the inventive methods when the computer program runs on a computer.

[0123] While the foregoing has been particularly shown and described with reference to particular embodiments thereof, it will be understood by those skilled in the art that various other changes in the form and details may be made without departing from the scope thereof. It is to be understood that various changes may be made in adapting to different embodiments without departing from the scope of the invention which is defined in the claims.

Claims

1. Multi-channel audio decoder (200) for processing a parametric representation (202), wherein the parametric representation (202) is comprising a stereo parameter (206) describing spatial properties of a stereo downmix of the multi-channel signal and information on one or more spatial parameters (204) describing spatial properties of a multi-channel signal, the information on one or more spatial parameters depending on the stereo parameter, wherein the information on the one or more spatial parameters (204) and the stereo parameter (206), when combined using a combination rule, results in one or more spatial parameters (210), the decoder comprising:

a parameter reconstructor (208) for combining the stereo parameter (206) and the information on the one or more spatial parameters (204) using the combination rule to obtain the one or more spatial parameters (210).

2. Multi-channel audio decoder (200) according to claim 1, in which the combination rule is such that the combination comprises a replacement of a first subset of parameters of the information on the one or more spatial parameters (204) by replacement parameters derived by combining the stereo parameter (206) and the first subset of the parameters.

3. Multi-channel audio decoder (200) in accordance with claim 2, in which the combination rule is such that a replacement parameter is derived by a linear combination of the corresponding parameter from the first subset of parameters and of a prediction of the same parameter, wherein the prediction is derived using parameters of a second subset of the informations on the one or more spatial parameters (204) and the stereo parameter (206), combining them using a prediction rule.

4. Multi-channel audio decoder (200) in accordance with claim 3, in which the prediction rule is such that the prediction is derived using the stereo parameter (206).

5. Multi-channel audio decoder (200) in accordance with claim 4, in which the prediction rule is such that the stereo parameter (206) is used as the prediction of the spatial parameter.

6. Multi-channel audio decoder (200) in accordance with one of the previous claims, in which the stereo parameter (206) is comprising a first parameter P_1 describing an intensity difference between the channels of the stereo downmix and a second parameter P_2 describing a correlation between the channels of the stereo downmix; in which the second subset of parameters is comprising a parameter S_3 describing an intensity difference between a sum of a left channel and a right channel of the multi-channel signal and a center channel of the multi-channel signal; and in which the prediction rule is such that a parameter S_1 of the first subset of parameters, the parameter describing an intensity difference between the left channel and the right channel of the multi-channel signal, is predicted by a prediction parameter \hat{S}_1 according to the following formulas:

$$\hat{S}_1 = \sqrt{\hat{X} / \hat{Y}} ,$$

wherein

$$\hat{X} = \frac{P_1^2 S_3^2 + q^2 (P_1^2 - 1)}{P_1^2 + 1}, \quad \hat{Y} = \frac{S_3^2 - q^2 (P_1^2 - 1)}{P_1^2 + 1}$$

- 5
7. Multi-channel audio decoder (200; 220) in accordance with one of the previous claims, in which the parameter reconstructor (226) is further comprising a decision unit (252) for deciding whether the first subset of parameters is replaced by replacement parameters or not.
- 10
8. Multi-channel audio decoder (200; 220) in accordance with one of the previous claims, further comprising a bitstream decomposer (222) to decompose a representation of the stereo parameter (234) and representation of the information on the one or more spatial parameters (232) from a bitstream (230), wherein the bitstream (230) is backwards compatible to be processible by legacy parametric stereo devices.
- 15
9. Multi-channel audio decoder (200; 220) in accordance with claim 8, further comprising an entropy decoder and a differential decoder (258, 260, 262a, 262b) to derive the stereo parameter (272) and the information on the one or more spatial parameters (266, 268) from the representation of the stereo parameter (234) and from the representation of the information on the one or more spatial parameters (232).
- 20
10. Multi-channel audio decoder (220) in accordance with claim 8 or 9, in which the bitstream decomposer (222) is further operative to decompose a monophonic downmix signal (236) from the bitstream, the monophonic downmix signal (236) being a monophonic downmix of the multi-channel signal; and which is further comprising an upmixer (228) for deriving a reconstruction of the multi-channel signal (240) using the downmix signal (236) and the one or more parameters (238).
- 25
11. Multi-channel audio decoder (220) in accordance with claim 10, further comprising an audio decoder (224) for deriving the monophonic downmix signal (236) from an encoded representation of the monophonic downmix signal (231) decomposed from the bitstream (230).
- 30
12. Encoder (10) for deriving a parametric representation (12) of a multi-channel audio signal, the parametric representation (12) having parameters suited to be used together with a monophonic downmixed signal, the encoder (10) comprising:
- 35
- a spatial parameter calculator (14) for calculating one or more spatial parameters (20) describing spatial properties of the multi-channel signal;
 - a stereo parameter calculator (16) for calculating a stereo parameter (22) describing spatial properties of a Stereo downmix signal derived from the multi-channel signal; and
 - a parameter combiner (18) for generating the parametric representation (12) by combining the one or more spatial parameters (20) and the stereo parameters (22) using a combination rule, wherein the parameter combiner (18) is operative to use a combination rule resulting in a decoder usable stereo parameter (24) and an information on the one or more spatial parameters (26), the information on one or more spatial parameters depending on the stereo parameter, which represents, together with the decoder usable stereo parameter (24), the one or more spatial parameters (20).
- 40
- 45
13. Encoder (10; 52) in accordance with claim 12, in which the stereo parameter calculator (16) is further comprising a stereo downmixer (58) for deriving the stereo-downmix signal (72) from the multi-channel signal (50).
- 50
14. Encoder (10; 52) in accordance with claims 12 or 13, further comprising a spatial downmixer (54) for deriving the monophonic downmix (68) signal from the multi-channel signal (50).
- 55
15. Encoder (10; 52) in accordance with one of the claims 12 to 14, further comprising a bitstream calculator (66) for deriving a bitstream (82) comprising the parametric representation and the monophonic downmix in a way that is backwards compatible to legacy parametric stereo decoders.
16. Encoder in accordance with claim 14 or 15, is which the spatial downmixer (54) is further comprising an audio encoder (62) for compression of the monophonic downmix signal (68) using a compression rule.

5 17. Method for processing a parametric representation, wherein the parametric representation is comprising a stereo parameter (206) describing spatial properties of a stereo downmix of the multi-channel signal and information on one or more spatial parameters describing spatial properties of a multi-channel signal, the information on one or more spatial parameters depending on the stereo parameter, wherein the information on the one or more spatial parameters and the stereo parameters, when combined using a combination rule, results in the one or more spatial parameters, the method comprising:

10 combining the stereo parameter and the information on the one or more spatial parameters using the combination rule to obtain the one or more spatial parameters.

18. Method for deriving a parametric representation of a multi-channel audio signal, the parametric representation having parameters suited to be used together with a monophonic downmix signal, the method comprising:

15 calculating one or more spatial parameters describing spatial properties of the multi-channel signal;
calculating a stereo parameter describing spatial properties of a stereo downmix signal derived from the multi-channel signal; and
generating the parametric representation by combining the one or more spatial parameters and the stereo parameter using a combination rule, wherein using the combination rule results in a decoder usable stereo parameter and in information on the one or more spatial parameters, the information on one or more spatial parameters depending on the stereo parameter, which represents, together with the decoder usable stereo parameter, the one or more spatial parameters.

20 19. Parametric representation of a multi-channel audio signal, the parametric representation having parameters suited to be used together with a monophonic downmix signal, wherein the parametric representation is having a decoder usable stereo parameter describing spatial properties of a stereo downmix of the multi-channel signal and information on one or more spatial parameters generated by combining one or more spatial parameters describing spatial properties of the multi-channel audio signal and the stereo parameter, the information on one or more spatial parameters depending on the stereo parameter, such that the information on the one or more spatial parameters represents, together with the decoder usable stereo parameter, the one or more spatial parameters.

25 20. Computer readable storage medium having stored thereon a parametric representation of a multi-channel audio signal in accordance with claim 19.

30 21. Transmitter or audio recorder (330) having an encoder for deriving a parametric representation of a multi-channel audio signal in accordance with claim 12.

22. Receiver or audio player (340) having a Multi-channel audio decoder (200) in accordance with claim 1.

35 23. Method of transmitting or audio recording, the method having a method for deriving a parametric representation of a multi-channel audio signal according to claim 18.

40 24. Method of receiving or audio playing, the method having a method for processing a parametric representation according to claim 17.

45 25. Transmission system having a transmitter (330) and a receiver (340);
the transmitter (330) having an encoder for deriving a parametric representation of a multi-channel audio signal in accordance with claim 12; and
the receiver (340) having a multi-channel audio decoder in accordance with claim 1.

50 26. Method of transmitting and receiving, the method including a transmitting method having a method for deriving a parametric representation of a multi-channel audio signal in accordance with claim 18 and
a receiving method, having a method for processing a parametric representation in accordance with claim 17.

55 27. Computer program for performing, when running on a computer, a method in accordance with any of the method claims 17, 18, 23, 24 or 26.

Patentansprüche

1. Mehrkanalaudiodecoder (200) zum Verarbeiten einer parametrischen Darstellung (202), wobei die parametrische Darstellung (202) einen Stereoparameter (206) aufweist, der räumliche Eigenschaften einer Stereoabwärtsmischung des Mehrkanalsignals und eine Information über einen oder mehrere räumliche Parameter (204), die räumliche Eigenschaften eines Mehrkanalsignals beschreibt, aufweist, wobei die Information über einen oder mehrere räumliche Parameter von dem Stereoparameter abhängt, wobei die Information über den einen oder die mehreren räumlichen Parameter (204) und der Stereoparameter (206), wenn sie unter Verwendung einer Kombinationsregel kombiniert werden, einen oder mehrere räumliche Parameter (210) ergeben, wobei der Decoder folgende Merkmale aufweist:

einen Parameterwiederhersteller (208) zum Kombinieren des Stereoparameters (206) mit der Information über den einen oder die mehreren räumlichen Parameter (204) unter Verwendung der Kombinationsregel, um den einen oder die mehreren räumlichen Parameter (210) zu erhalten.

2. Mehrkanalaudiodecoder (200) gemäß Anspruch 1, bei dem die Kombinationsregel derart ist, dass die Kombination eine Ersetzung eines ersten Teilsatzes von Parametern der Information über den einen oder die mehreren räumlichen Parameter (204) durch Ersetzungsparameter, die durch Kombinieren des Stereoparameters (206) mit dem ersten Teilsatz der Parameter abgeleitet werden, aufweist.

3. Mehrkanalaudiodecoder (200) gemäß Anspruch 2, bei dem die Kombinationsregel derart ist, dass ein Ersetzungsparameter durch eine lineare Kombination des entsprechenden Parameters aus dem ersten Teilsatz von Parametern mit einer Voraussage desselben Parameters abgeleitet ist, wobei die Voraussage unter Verwendung von Parametern eines zweiten Teilsatzes der Information über den einen oder die mehreren räumlichen Parameter (204) und des Stereoparameters (206), wobei dieselben unter Verwendung einer Voraussageregeln kombiniert werden, abgeleitet ist.

4. Mehrkanalaudiodecoder (200) gemäß Anspruch 3, bei dem die Voraussageregeln derart ist, dass die Voraussage unter Verwendung des Stereoparameters abgeleitet wird.

5. Mehrkanalaudiodecoder (200) gemäß Anspruch 4, bei dem die Voraussageregeln derart ist, dass der Stereoparameter (206) als die Voraussage des räumlichen Parameters verwendet wird.

6. Mehrkanalaudiodecoder (200) gemäß einem der vorhergehenden Ansprüche, bei dem der Stereoparameter (206) einen ersten Parameter P_1 , der eine Intensitätsdifferenz zwischen den Kanälen der Stereoabwärtsmischung beschreibt, und einen zweiten Parameter P_2 , der eine Korrelation zwischen den Kanälen der Stereoabwärtsmischung beschreibt, aufweist;

wobei der zweite Teilsatz von Parametern einen Parameter S_3 aufweist, der eine Intensitätsdifferenz zwischen einer Summe aus einem linken Kanal und einem rechten Kanal des Mehrkanalsignals und einem Mittelkanal des Mehrkanalsignals beschreibt; und

wobei die Voraussageregeln derart ist, dass ein Parameter S_1 des ersten Teilsatzes von Parametern, wobei der Parameter eine Intensitätsdifferenz zwischen dem linken Kanal und dem rechten Kanal des Mehrkanalsignals beschreibt, durch einen Voraussageparameter \hat{S}_1 gemäß den folgenden Formeln vorausgesagt wird:

$$\hat{S}_1 = \sqrt{\hat{X} / \hat{Y}} ,$$

wobei

$$\hat{X} = \frac{P_1^2 S_3^2 + q^2 (P_1^2 - 1)}{P_1^2 + 1} , \quad \hat{Y} = \frac{S_3^2 - q^2 (P_1^2 - 1)}{P_1^2 + 1} .$$

7. Mehrkanalaudiodecoder (200; 220) gemäß einem der vorhergehenden Ansprüche, bei dem der Parameterwiederhersteller (226) ferner eine Entscheidungseinheit (252) zum Entscheiden, ob der erste Teilsatz von Parametern

durch die Ersetzungsparameter ersetzt wird oder nicht, aufweist.

- 5
8. Mehrkanalaudiodecoder (200; 220) gemäß einem der vorhergehenden Ansprüche, der ferner einen Bitstromzerleger (222) zum Zerlegen einer Darstellung des Stereoparameters (234) und einer Darstellung der Information über den einen oder die mehreren räumlichen Parameter (232) aus einem Bitstrom (230) aufweist, wobei der Bitstrom (230) rückwärtskompatibel ist, um durch parametrische Vorläuferstereovorrichtungen bearbeitbar zu sein.
- 10
9. Mehrkanalaudiodecoder (200; 220) gemäß Anspruch 8, der ferner einen Entropie-Decoder und einen Differenzdecoder (258, 260, 262a, 262b) aufweist, um den Stereoparameter (272) und die Information über den einen oder die mehreren räumlichen Parameter (266, 268) aus der Darstellung des Stereoparameters (234) und aus der Darstellung der Information über den einen oder die mehreren räumlichen Parameter (232) abzuleiten.
- 15
10. Mehrkanalaudiodecoder (220) gemäß Anspruch 8 oder 9, bei dem der Bitstromzerleger (222) ferner wirksam ist, um ein monophones Abwärtsmischsignal (236) aus dem Bitstrom zu zerlegen, wobei das monophone Abwärtsmischsignal (236) eine monophone Abwärtsmischung des Mehrkanalsignals ist; und der ferner einen Aufwärtsmischer (228) zum Ableiten einer Wiederherstellung des Mehrkanalsignals (240) unter Verwendung des Abwärtsmischsignals (236) und des einen oder der mehreren Parameter (238) aufweist.
- 20
11. Mehrkanalaudiodecoder (220) gemäß Anspruch 10, der ferner einen Audiodecoder (224) zum Ableiten des monophonen Abwärtsmischsignals (236) aus einer codierten Darstellung des monophonen Abwärtsmischsignals (231), das aus dem Bitstrom (230) zerlegt wurde, aufweist.
- 25
12. Codierer (10) zum Ableiten einer parametrischen Darstellung (12) eines Mehrkanaludiosignals, wobei die parametrische Darstellung (12) Parameter aufweist, die dafür geeignet sind, zusammen mit einem monophonen Abwärtsmischsignal verwendet zu werden, wobei der Codierer (10) folgende Merkmale aufweist:
- 30
- einen Räumlicher-Parameter-Berechner (14) zum Berechnen eines oder mehrerer räumlicher Parameter (20), die räumliche Eigenschaften des Mehrkanalsignals beschreiben;
- einen Stereoparameter-Berechner (16) zum Berechnen eines Stereoparameters (22), der räumliche Eigenschaften eines Stereoabwärtsmischsignals beschreibt, das aus dem Mehrkanalsignal abgeleitet ist; und
- 35
- einen Parameterkombinierer (18) zum Erzeugen der parametrischen Darstellung (12) durch Kombinieren des einen oder der mehreren räumlichen Parameter (20) mit den Stereoparametern (22) unter Verwendung einer Kombinationsregel, wobei der Parameterkombinierer (18) wirksam ist, um eine Kombinationsregel zu verwenden, was einen durch einen Decoder verwendbaren Stereoparameter (24) und eine Information über den einen oder die mehreren räumlichen Parameter (26) ergibt, wobei die Information über einen oder mehrere räumliche Parameter von dem Stereoparameter abhängt, der, zusammen mit dem durch einen Decoder verwendbaren Stereoparameter (24) den einen oder die mehreren räumlichen Parameter (20) darstellt.
- 40
13. Codierer (10; 52) gemäß Anspruch 12, bei dem der Stereoparameter-Berechner (16) ferner einen Stereoabwärtsmischer (58) zum Ableiten des Stereoabwärtsmischsignals (72) aus dem Mehrkanalsignal (50) aufweist.
- 45
14. Codierer (10; 52) gemäß Anspruch 12 oder 13, der ferner einen räumlichen Abwärtsmischer (54) zum Ableiten des monophonen Abwärtsmischsignals (68) aus dem Mehrkanalsignal (50) aufweist.
- 50
15. Codierer (10; 52) gemäß einem der Ansprüche 12 bis 14, der ferner einen Bitstromberechner (66) zum Ableiten eines Bitstroms (82) aufweist, der die parametrische Darstellung und die monophone Abwärtsmischung in einer Weise aufweist, die rückwärtskompatibel auf parametrische Vorläuferstereodecoder ist.
- 55
16. Codierer gemäß Anspruch 14 oder 15, bei dem der räumliche Abwärtsmischer (54) ferner einen Audiocodierer (62) zur Verdichtung des monophonen Abwärtsmischsignals (68) unter Verwendung einer Verdichtungsregel aufweist.
17. Verfahren zum Verarbeiten einer parametrischen Darstellung, wobei die parametrische Darstellung einen Stereoparameter (206), der räumliche Eigenschaften einer Stereoabwärtsmischung des Mehrkanalsignals beschreibt, und eine Information über einen oder mehrere räumliche Parameter, die räumliche Eigenschaften eines Mehrkanalsignals beschreibt, aufweist, wobei die Information über den einen oder die mehreren räumlichen Parameter von dem Stereoparameter abhängt, wobei die Information über einen oder mehrere räumliche Parameter und die Stereoparameter, wenn sie unter Verwendung einer Kombinationsregel kombiniert werden, den einen oder die mehreren räumlichen Parameter ergeben, wobei das Verfahren folgende Schritte aufweist:

Kombinieren des Stereoparameters mit der Information über den einen oder die mehreren räumlichen Parameter unter Verwendung der Kombinationsregel, um den einen oder die mehreren räumlichen Parameter zu erhalten.

- 5 **18.** Verfahren zum Ableiten einer parametrischen Darstellung eines Mehrkanalaudiosignals, wobei die parametrische Darstellung Parameter aufweist, die geeignet sind, um zusammen mit einem monophonen Abwärtsmischsignal verwendet zu werden, wobei das Verfahren folgende Schritte aufweist:
- Berechnen eines oder mehrerer räumlicher Parameter, die räumliche Eigenschaften des Mehrkanalsignals beschreiben;
 10 Berechnen eines Stereoparameters, der räumliche Eigenschaften eines Stereoabwärtsmischsignals beschreibt, das aus dem Mehrkanalsignal abgeleitet ist; und
 Erzeugen der parametrischen Darstellung durch Kombinieren des einen oder der mehreren räumlichen Parameter mit dem Stereoparameter unter Verwendung einer Kombinationsregel, wobei das Verwenden der Kombinationsregel einen durch einen Decoder verwendbaren Stereoparameter und eine Information über den einen oder die mehreren räumlichen Parameter ergibt, wobei die Information über einen oder mehrere räumliche Parameter von dem Stereoparameter abhängt, der, zusammen mit dem durch einen Decoder verwendbaren Stereoparameter, den einen oder die mehreren räumlichen Parameter darstellt.
- 20 **19.** Parametrische Darstellung eines Mehrkanalaudiosignals, wobei die parametrische Darstellung Parameter aufweist, die geeignet sind, um zusammen mit einem monophonen Abwärtsmischsignal verwendet zu werden, wobei die parametrische Darstellung einen durch einen Decoder verwendbaren Stereoparameter, der räumliche Eigenschaften einer Stereoabwärtsmischung des Mehrkanalsignals beschreibt, und eine Information über einen oder mehrere räumliche Parameter, die durch Kombinieren eines oder mehrerer räumlicher Parameter, die räumliche Eigenschaften des Mehrkanalaudiosignals beschreiben, mit dem Stereoparameter erzeugt wird, aufweist, wobei die Information über einen oder mehrere räumliche Parameter von dem Stereoparameter abhängt, derart, dass die Information über den einen oder die mehreren räumlichen Parameter, zusammen mit dem durch einen Decoder verwendbaren Stereoparameter, den einen oder die mehreren räumlichen Parameter darstellt.
- 25 **20.** Computerlesbares Speicherungsmedium, auf dem eine parametrische Darstellung eines Mehrkanalaudiosignals gemäß Anspruch 19 gespeichert ist.
- 30 **21.** Sender oder Audioaufzeichnungsgerät (330), das einen Codierer zum Ableiten einer parametrischen Darstellung eines Mehrkanalaudiosignals gemäß Anspruch 12 aufweist.
- 35 **22.** Empfänger oder Audioabspielgerät (340) mit einem Mehrkanalaudiodecoder (200) gemäß Anspruch 1.
- 23.** Verfahren zum Senden einer Audioaufzeichnung, wobei das Verfahren ein Verfahren zum Ableiten einer parametrischen Darstellung eines Mehrkanalaudiosignals gemäß Anspruch 18 aufweist.
- 40 **24.** Verfahren zum Empfangen oder Audioabspielen, wobei das Verfahren ein Verfahren zum Verarbeiten einer parametrischen Darstellung gemäß Anspruch 17 aufweist.
- 25.** Sendesystem mit einem Sender (330) und einem Empfänger (340);
 wobei der Sender (330) einen Codierer zum Ableiten einer parametrischen Darstellung eines Mehrkanalaudiosignals gemäß Anspruch 12 aufweist; und
 45 wobei der Empfänger (340) einen Mehrkanalaudiodecoder gemäß Anspruch 1 aufweist.
- 26.** Verfahren zum Senden und Empfangen, wobei das Verfahren ein Sendeverfahren mit einem Verfahren zum Ableiten einer parametrischen Darstellung eines Mehrkanalaudiosignals gemäß Anspruch 18 umfasst und
 50 ein Empfangsverfahren, das ein Verfahren zum Verarbeiten einer parametrischen Darstellung gemäß Anspruch 17 aufweist, umfasst.
- 27.** Computerprogramm zum Durchführen eines Verfahrens gemäß einem der Verfahrensansprüche 17, 18, 23, 24 oder 26, wenn es auf einem Computer abläuft.
- 55

Revendications

- 5 1. Décodeur audio multicanal (200) pour traiter une représentation paramétrique (202), dans lequel la représentation paramétrique (202) comprend un paramètre stéréo (206) décrivant les propriétés spatiales d'un mélange descendant stéréo du signal multicanal et des informations sur un ou plusieurs paramètres spatiaux (204) décrivant les propriétés spatiales d'un signal multicanal, les informations sur un ou plusieurs paramètres spatiaux dépendant du paramètre stéréo, dans lequel les informations sur l'un ou les plusieurs paramètres spatiaux (204) et le paramètre stéréo (206), lorsqu'ils sont combinés à l'aide d'une règle de combinaison, résultent en un ou plusieurs paramètres spatiaux (210), le décodeur comprenant:
- 10 un reconstituteur de paramètre (208) destiné à combiner le paramètre stéréo (206) et les informations sur l'un ou les plusieurs paramètres spatiaux (204) à l'aide de la règle de combinaison, pour obtenir l'un ou les plusieurs paramètres spatiaux (210).
- 15 2. Décodeur audio multicanal (200) selon la revendication 1, dans lequel la règle de combinaison est telle que la combinaison comprend un remplacement d'un premier sous-ensemble de paramètres des informations sur l'un ou les plusieurs paramètres spatiaux (204) par des paramètres de remplacement dérivés en combinant le paramètre stéréo (206) et le premier sous-ensemble des paramètres.
- 20 3. Décodeur audio multicanal (200) selon la revendication 2, dans lequel la règle de combinaison est telle qu'un paramètre de remplacement est dérivé par une combinaison linéaire du paramètre correspondant du premier sous-ensemble de paramètres et d'une prédiction du même paramètre, dans lequel la prédiction est dérivée à l'aide de paramètres d'un deuxième sous-ensemble des informations sur l'un ou les plusieurs paramètres spatiaux (204) et du paramètre stéréo (206) en les combinant à l'aide d'une règle de prédiction.
- 25 4. Décodeur audio multicanal (200) selon la revendication 3, dans lequel la règle de prédiction est telle que la prédiction est dérivée à l'aide du paramètre stéréo (206).
- 30 5. Décodeur audio multicanal (200) selon la revendication 4, dans lequel la règle de prédiction est telle que le paramètre stéréo (206) est utilisé comme prédiction du paramètre spatial.
- 35 6. Décodeur audio multicanal (200) selon l'une des revendications précédentes, dans lequel le paramètre stéréo (206) comprend un premier paramètre P_1 décrivant une différence d'intensité entre les canaux du mélange descendant stéréo et un deuxième paramètre P_2 décrivant une corrélation entre les canaux du mélange descendant stéréo; dans lequel le deuxième sous-ensemble de paramètres comprend un paramètre S_3 décrivant une différence d'intensité entre une somme d'un canal gauche et d'un canal droit du signal multicanal et un canal central du signal multicanal; et dans lequel la règle de prédiction est telle qu'un paramètre S_1 du premier sous-ensemble de paramètres, le paramètre décrivant une différence d'intensité entre le canal gauche et le canal droit du signal multicanal, est prédit par un paramètre de prédiction \hat{S}_1 selon les formules suivantes :
- 40

$$\hat{S}_1 = \sqrt{\hat{X} / \hat{Y}},$$

45 où

$$50 \quad \hat{X} = \frac{P_1^2 S_3^2 + q^2 (P_1^2 - 1)}{P_1^2 + 1}, \quad \hat{Y} = \frac{S_3^2 - q^2 (P_1^2 - 1)}{P_1^2 + 1}$$

- 55 7. Décodeur audio multicanal (200; 220) selon l'une des revendications précédentes, dans lequel le reconstituteur de paramètre (226) comprend par ailleurs une unité de décision (252) destinée à décider si le premier sous-ensemble de paramètres est remplacé ou non par des paramètres de remplacement.
8. Décodeur audio multicanal (200; 220) selon l'une des revendications précédentes, comprenant par ailleurs un

décomposeur de train binaire (222) destiné à décomposer une représentation du paramètre stéréo (234) et une représentation des informations sur l'un ou les plusieurs paramètres spatiaux (232) à partir d'un train binaire (230), où le train binaire (230) est compatible en arrière de manière à pouvoir être traité par des dispositifs stéréo paramétriques récupérés.

- 5
9. Décodeur audio multicanal (200; 220) selon la revendication 8, comprenant par ailleurs un décodeur entropique et un décodeur différentiel (258, 260, 262a, 262b) pour dériver le paramètre stéréo (272) et les informations sur l'un ou les plusieurs paramètres spatiaux (266, 268) de la représentation du paramètre stéréo (234) et de la représentation des informations sur l'un ou les plusieurs paramètres spatiaux (232).
- 10
10. Décodeur audio multicanal (220) selon la revendication 8 ou 9, dans lequel le décomposeur de train binaire (222) est par ailleurs opérationnel pour décomposer un signal de mélange ascendant monophonique (236) du train binaire, le signal de mélange descendant monophonique (236) étant un mélange descendant monophonique du signal multicanal; et
- 15
- qui comprend par ailleurs un mélangeur ascendant (228) destiné à dériver une reconstruction du signal multicanal (240) à l'aide du signal de mélange descendant (236) et de l'un ou des plusieurs paramètres (238).
11. Décodeur audio multicanal (220) selon la revendication 10, comprenant par ailleurs un décodeur audio (224) destiné à dériver le signal de mélange descendant monophonique (236) d'une représentation codée du signal de mélange descendant monophonique (231) décomposé du train binaire (230).
- 20
12. Codeur (10) pour dériver une représentation paramétrique (12) d'un signal audio multicanal, la représentation paramétrique (12) présentant des paramètres convenant pour être utilisés ensemble avec un signal de mélange descendant monophonique, le codeur (10) comprenant:
- 25
- un calculateur de paramètres spatiaux (14) destiné à calculer un ou plusieurs paramètres spatiaux (20) décrivant des propriétés spatiales du signal multicanal;
- un calculateur de paramètre stéréo (16) destiné à calculer un paramètre stéréo (22) décrivant les propriétés spatiales d'un signal de mélange descendant stéréo dérivé du signal multicanal; et
- 30
- un combineur de paramètres (18) destiné à générer la représentation paramétrique (12) en combinant l'un ou les plusieurs paramètres spatiaux (20) et les paramètres stéréo (22) à l'aide d'une règle de combinaison, où le combineur de paramètres (18) est opérationnel pour utiliser une règle de combinaison résultant en un paramètre stéréo utilisable dans un décodeur (24) et une information sur l'un ou les plusieurs paramètres spatiaux (26), l'information sur l'un ou les plusieurs paramètres spatiaux dépendant du paramètre stéréo qui représente,
- 35
- ensemble avec le paramètre stéréo utilisable dans un décodeur (24), l'un ou les plusieurs paramètres spatiaux (20).
13. Codeur (10; 52) selon la revendication 12, dans lequel le calculateur de paramètre stéréo (16) comprend par ailleurs un mélangeur descendant stéréo (58) destiné à dériver le signal de mélange descendant stéréo (72) du signal multicanal (50).
- 40
14. Codeur (10; 52) selon les revendications 12 ou 13, comprenant par ailleurs un mélangeur descendant spatial (54) destiné à dériver le signal de mélange descendant monophonique (68) du signal multicanal (50).
15. Codeur (10; 52) selon l'une des revendications 12 à 14, comprenant par ailleurs un calculateur de train binaire (66) destiné à dériver un train binaire (82) comprenant la représentation paramétrique et le mélange descendant monophonique de manière compatible en arrière avec les décodeurs stéréo paramétriques récupérés.
- 45
16. Codeur selon la revendication 14 ou 15, dans lequel le mélangeur descendant spatial (54) comprend par ailleurs un codeur audio (62) destiné à comprimer le signal de mélange descendant monophonique (68) à l'aide d'une règle de compression.
- 50
17. Procédé pour traiter une représentation paramétrique, dans lequel la représentation paramétrique comprend un paramètre stéréo (206) décrivant les propriétés spatiales d'un mélange descendant stéréo du signal multicanal et des informations sur un ou plusieurs paramètres spatiaux décrivant les propriétés spatiales d'un signal multicanal, les informations sur un ou plusieurs paramètres spatiaux dépendant du paramètre stéréo, dans lequel les informations sur l'un ou les plusieurs paramètres spatiaux et les paramètres stéréo, lorsqu'ils sont combinés à l'aide d'une règle de combinaison, résultant en un ou plusieurs paramètres spatiaux, le procédé comprenant:
- 55

combiner le paramètre stéréo et les informations sur l'un ou les plusieurs paramètres spatiaux à l'aide de la règle de combinaison, pour obtenir l'un ou les plusieurs paramètres spatiaux.

- 5
- 18.** Procédé pour dériver une représentation paramétrique d'un signal audio multicanal, la représentation paramétrique présentant des paramètres convenant pour être utilisés ensemble avec un signal de mélange descendant monophonique, le procédé comprenant:
- calculer un ou plusieurs paramètres spatiaux décrivant les propriétés spatiales du signal multicanal;
calculer un paramètre stéréo décrivant les propriétés spatiales d'un signal de mélange descendant stéréo dérivé du signal multicanal; et
généraliser la représentation paramétrique en combinant l'un ou les plusieurs paramètres spatiaux et le paramètre stéréo à l'aide d'une règle de combinaison, dans lequel l'utilisation de la règle de combinaison résulte en un paramètre stéréo utilisable dans un décodeur et en des informations sur l'un ou les plusieurs paramètres spatiaux, les informations sur un ou plusieurs paramètres spatiaux dépendant du paramètre stéréo, qui représente, ensemble avec le paramètre stéréo utilisable dans un décodeur, l'un ou les plusieurs paramètres spatiaux.
- 10
- 19.** Représentation paramétrique d'un signal audio multicanal, la représentation paramétrique présentant des paramètres convenant pour être utilisés ensemble avec un signal de mélange descendant monophonique, dans laquelle la représentation paramétrique présente un paramètre stéréo utilisable dans un décodeur décrivant les propriétés spatiales d'un mélange descendant stéréo du signal multicanal et des informations sur un ou plusieurs paramètres spatiaux générés en combinant un ou plusieurs paramètres spatiaux décrivant les propriétés spatiales du signal audio multicanal et le paramètre stéréo, les informations sur un ou plusieurs paramètres spatiaux dépendant du paramètre stéréo, de sorte que les informations sur l'un ou les plusieurs paramètres spatiaux représentent, ensemble avec le paramètre stéréo utilisable dans un décodeur, l'un ou les plusieurs paramètres spatiaux.
- 15
- 20.** Support de mémoire lisible en machine ayant, y mémorisée, une représentation paramétrique d'un signal audio multicanal selon la revendication 19.
- 21.** Emetteur ou enregistreur audio (330) présentant un codeur pour dériver une représentation paramétrique d'un signal audio multicanal selon la revendication 12.
- 20
- 22.** Récepteur ou reproducteur audio (340) présentant un décodeur audio multicanal (200) selon la revendication 1.
- 23.** Procédé de transmission ou d'enregistrement audio, le procédé présentant un procédé pour dériver une représentation paramétrique d'un signal audio multicanal selon la revendication 18.
- 25
- 24.** Procédé de réception ou de reproduction audio, le procédé présentant un procédé pour traiter une représentation paramétrique selon la revendication 17.
- 25.** Système de transmission présentant un émetteur (330) et un récepteur (340); l'émetteur (330) présentant un codeur destiné à dériver une représentation paramétrique d'un signal audio multicanal selon la revendication 12; et le récepteur (340) présentant un décodeur audio multicanal selon la revendication 1.
- 30
- 26.** Procédé de transmission et de réception, le procédé comportant un procédé de transmission présentant un procédé pour dériver une représentation paramétrique d'un signal audio multicanal selon la revendication 18, et un procédé de réception présentant un procédé pour traiter une représentation paramétrique selon la revendication 17.
- 35
- 27.** Programme d'ordinateur pour réaliser, lorsqu'il est exécuté sur un ordinateur, un procédé selon l'une quelconque des revendications de procédé 17, 18, 23, 24 ou 26.
- 40
- 45
- 50
- 55

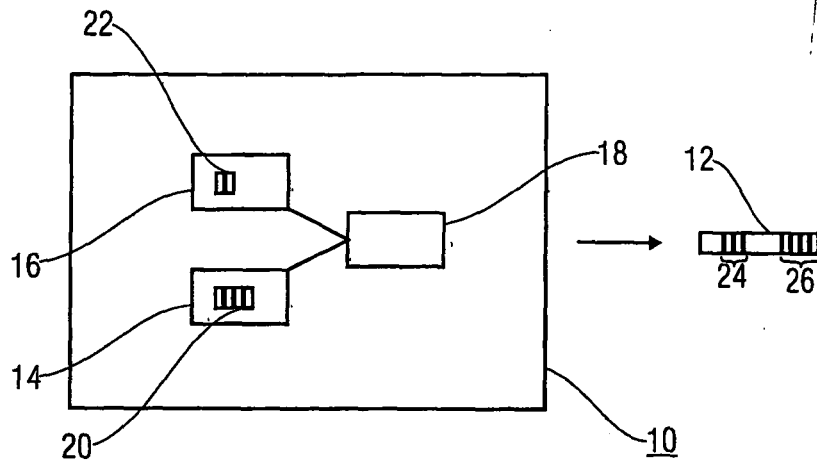

Fig. 1

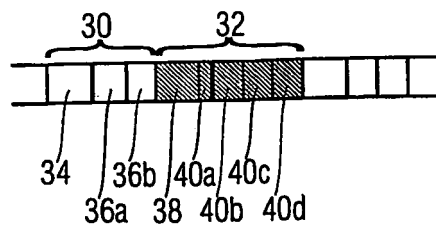
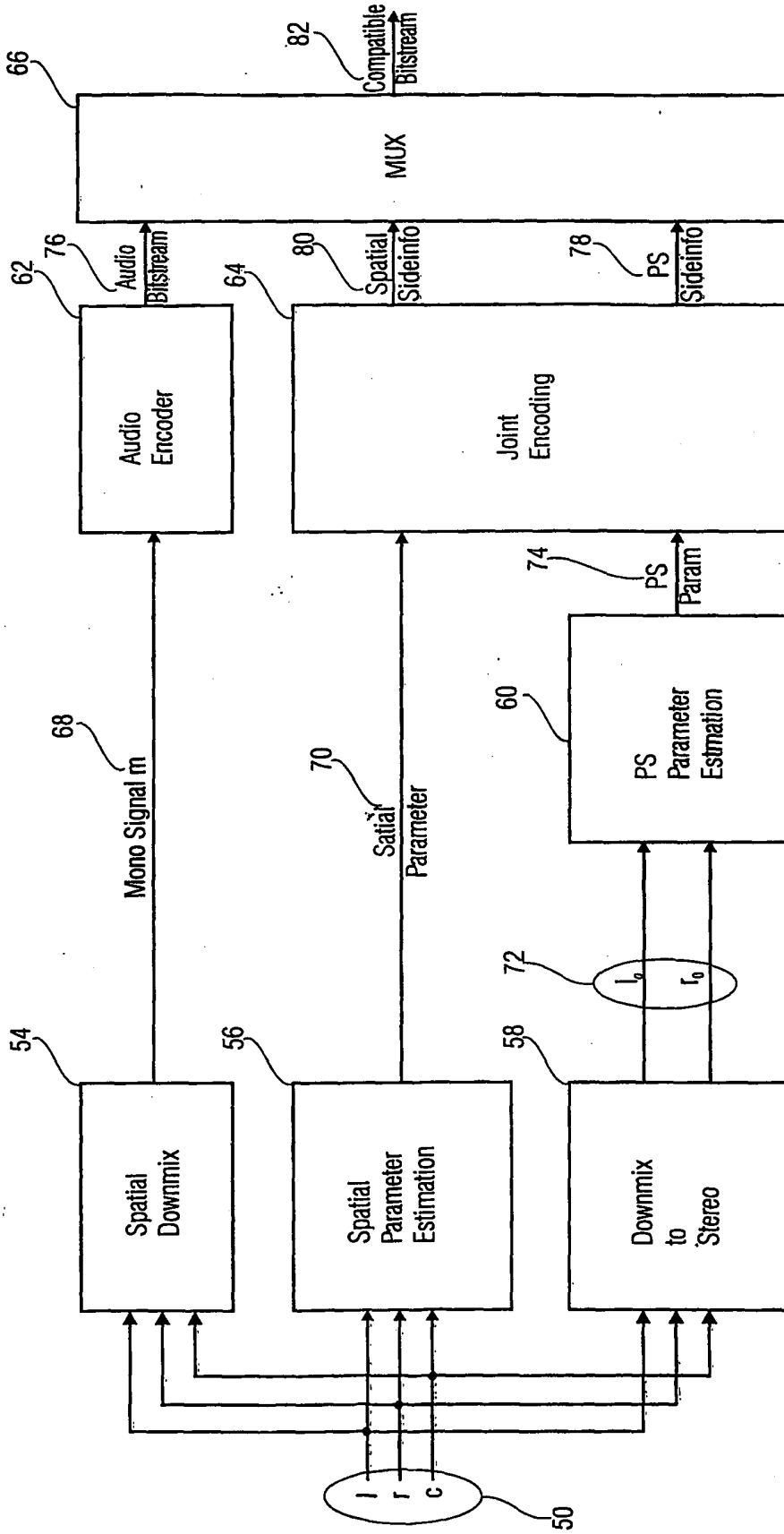

Fig. 2



52

Fig. 3

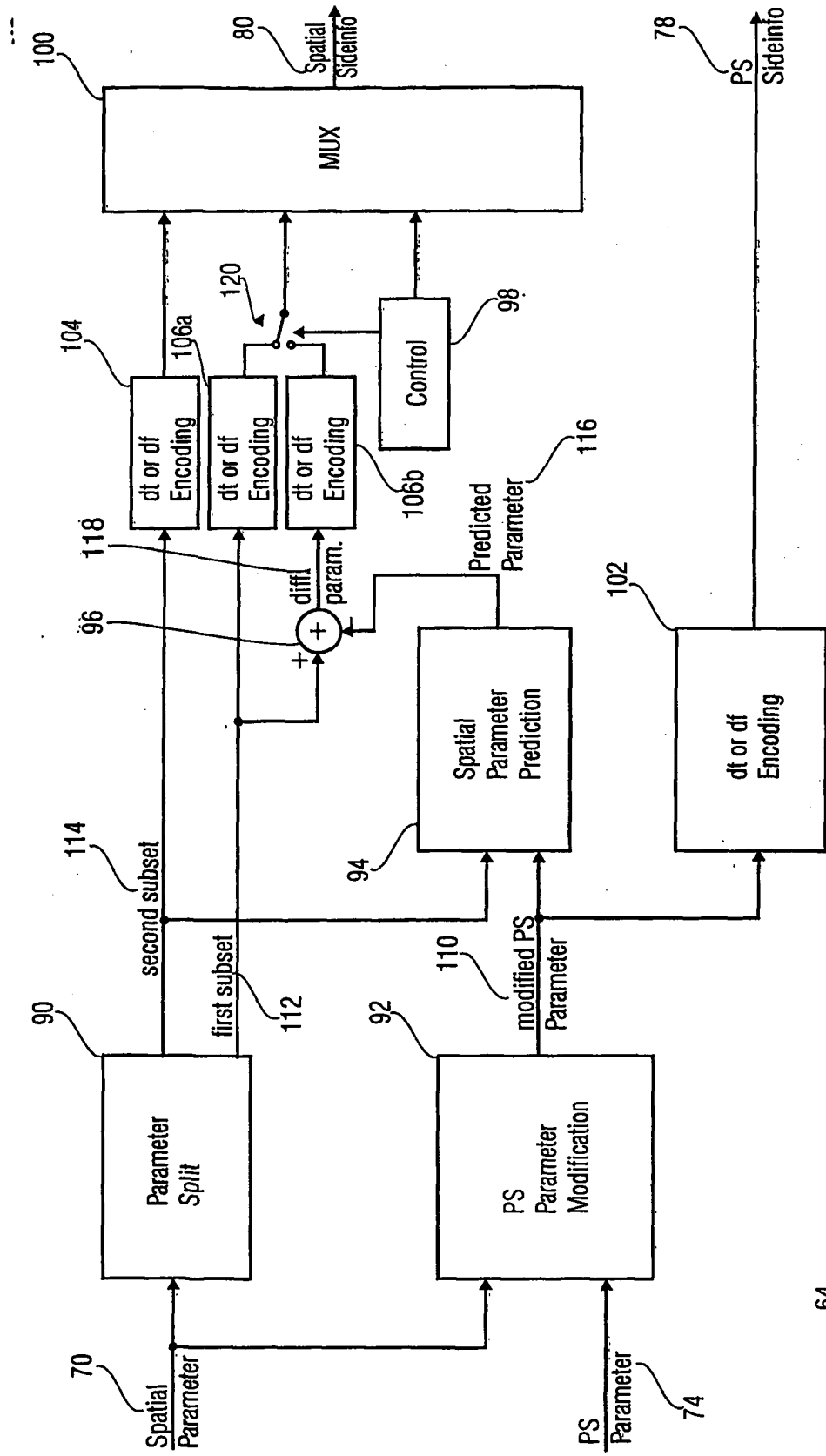

Fig. 4

64

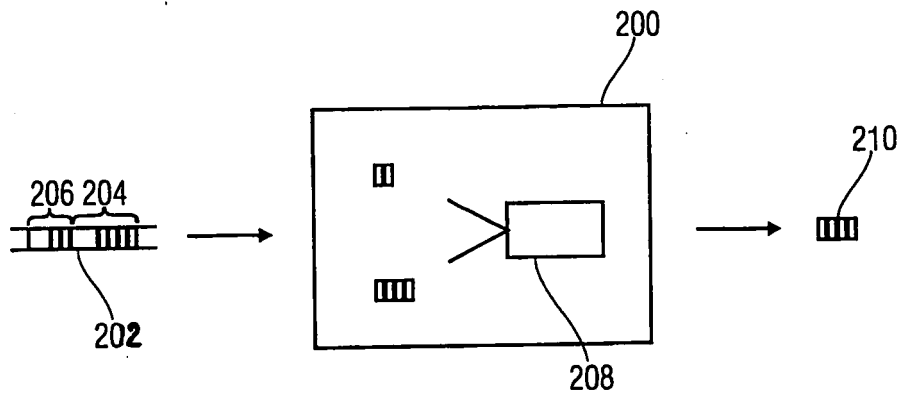

Fig. 5

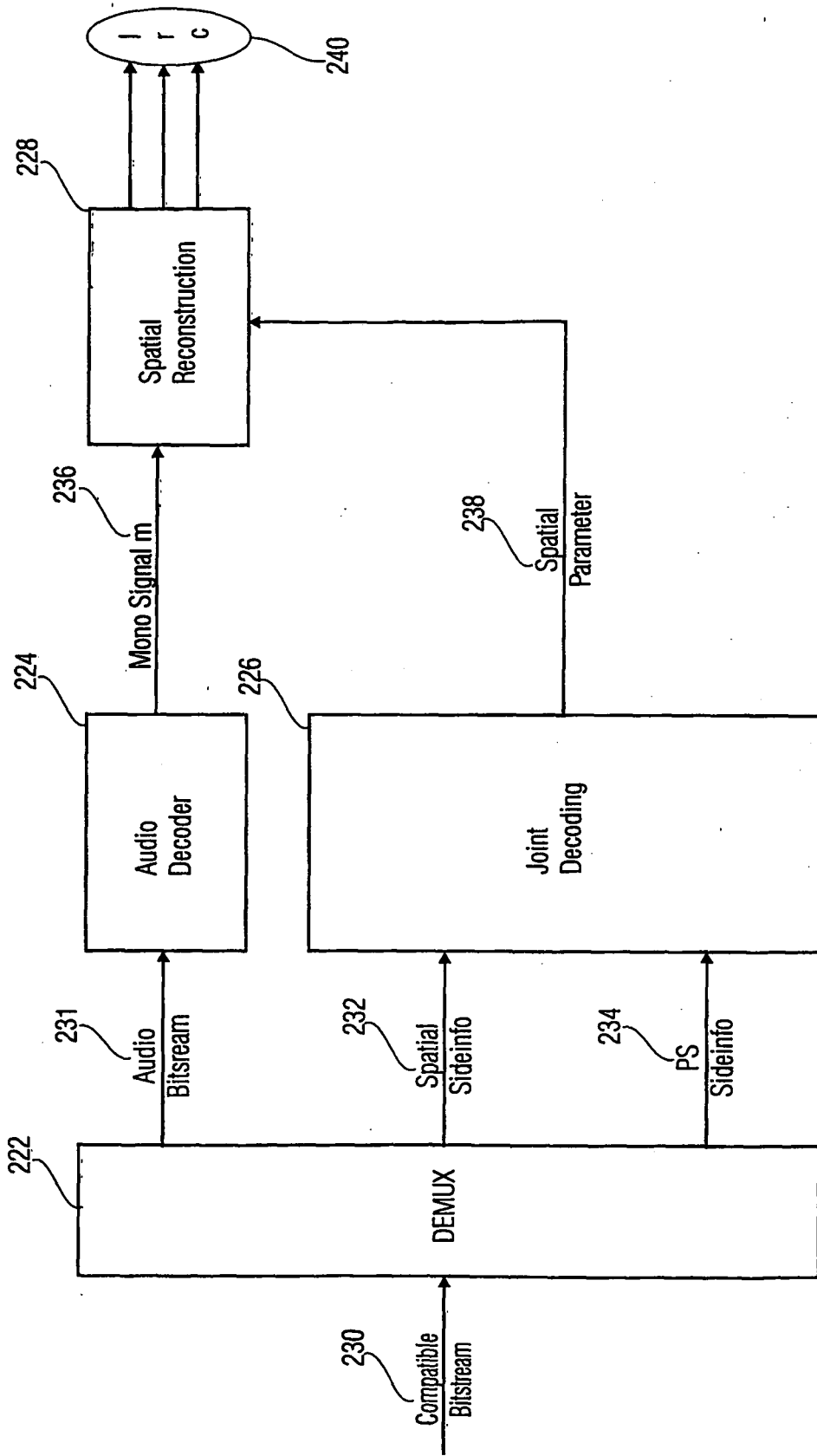

Fig. 6

220

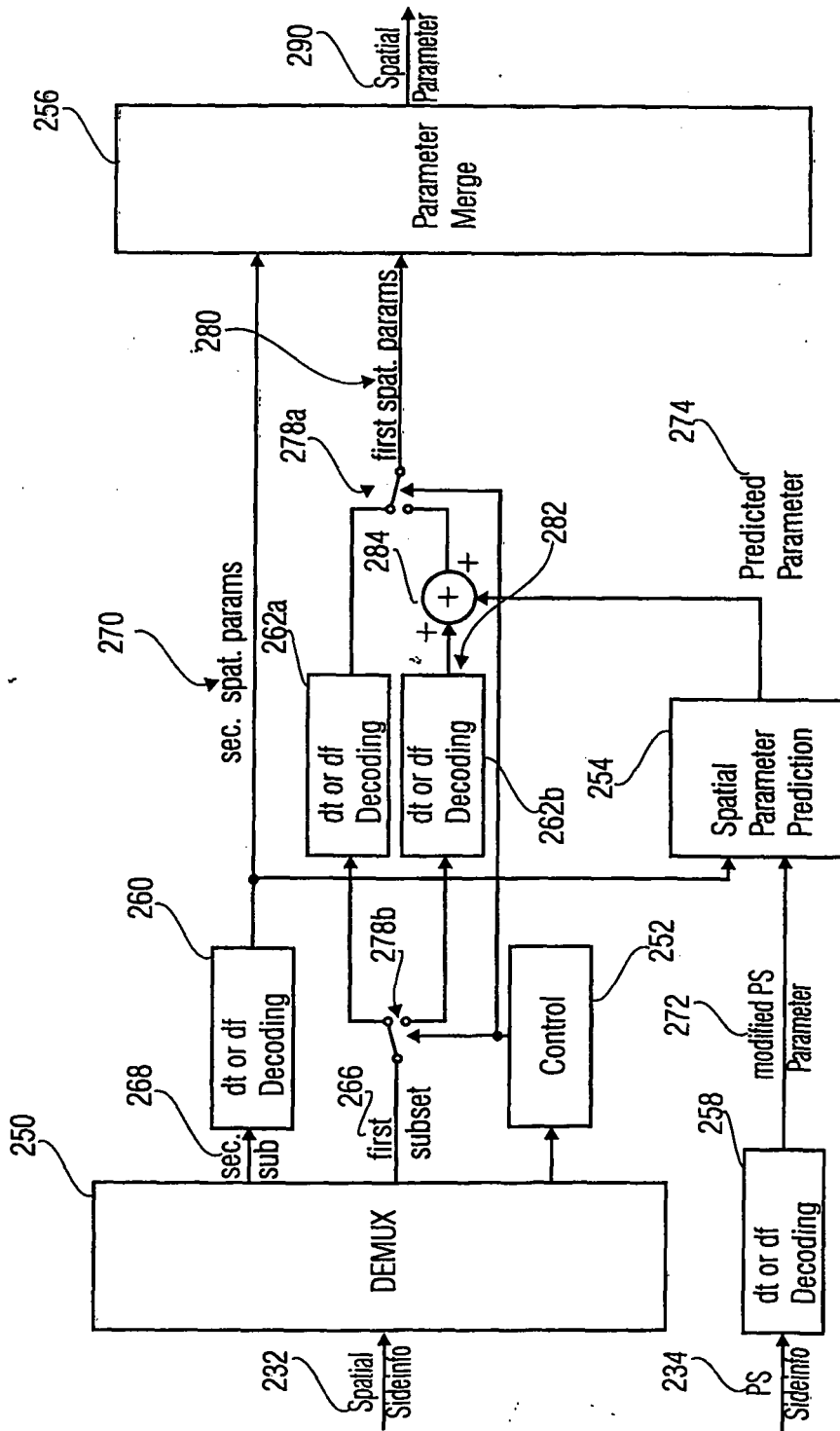

Fig. 7

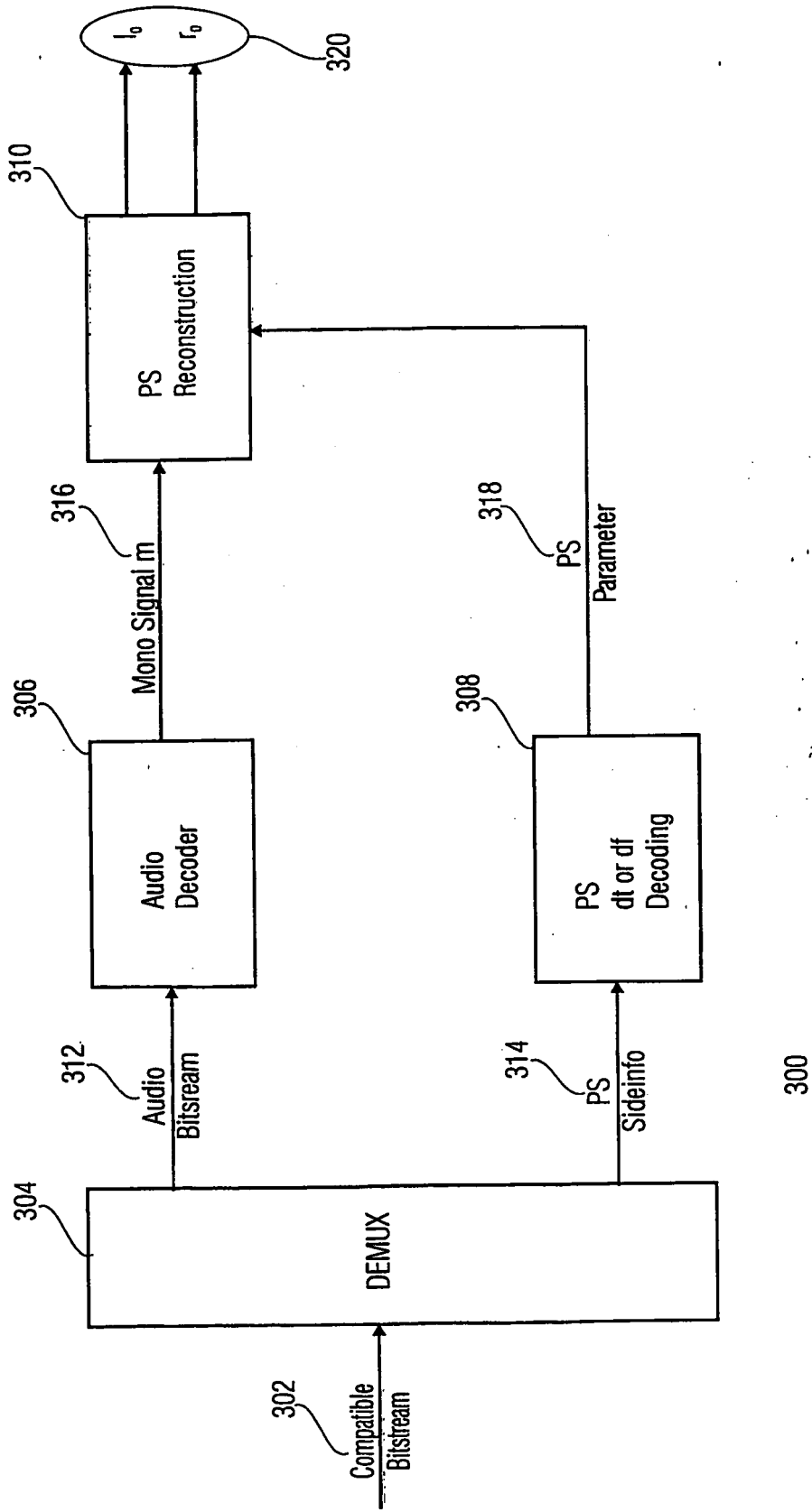

Fig. 8

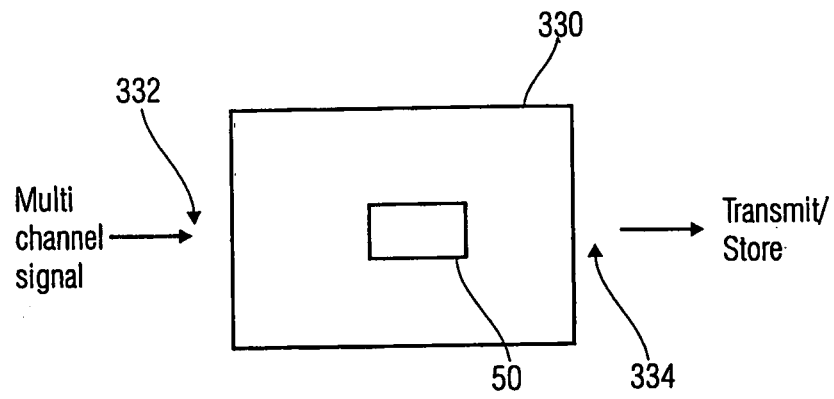

Fig. 9

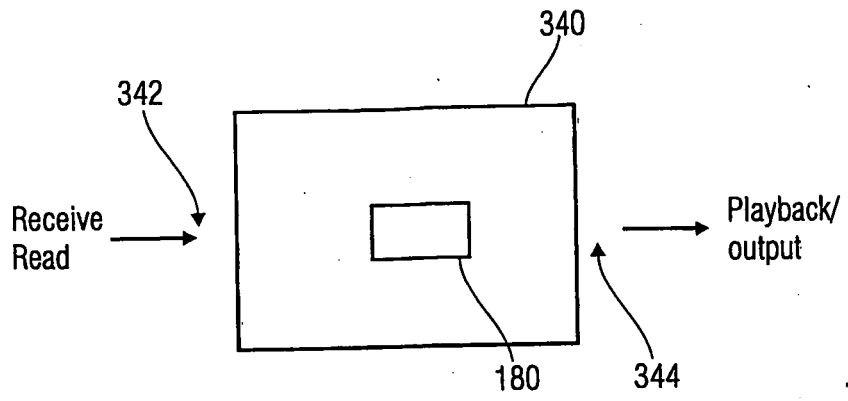

Fig. 10

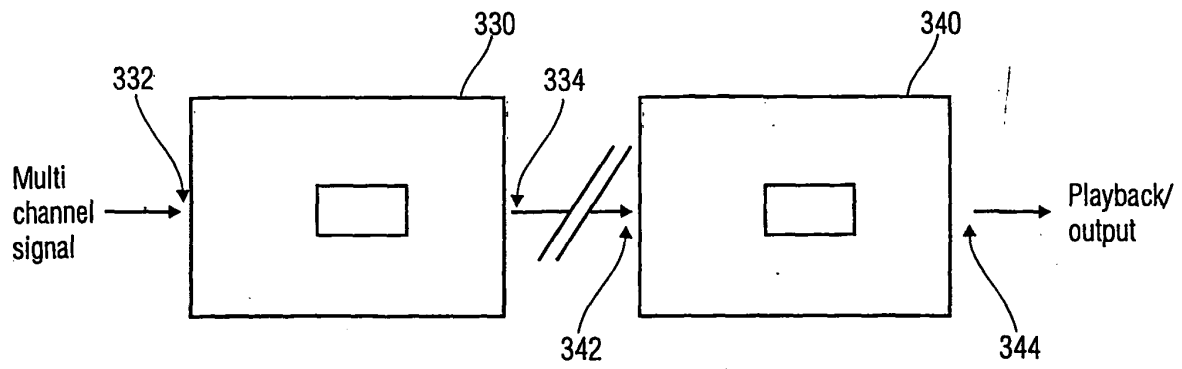

Fig. 11

REFERENCES CITED IN THE DESCRIPTION

This list of references cited by the applicant is for the reader's convenience only. It does not form part of the European patent document. Even though great care has been taken in compiling the references, errors or omissions cannot be excluded and the EPO disclaims all liability in this regard.

Patent documents cited in the description

- SE 0201372 W [0009]

Non-patent literature cited in the description

- **C. FALLER ; F. BAUMGARTE.** Binaural Cue Coding applied to Stereo and Multi-Channel Audio Compression. *AES convention paper 5574*, May 2002 [0005]
- **J. BREEBAART ; S. VAN DE PAR ; A. KOHLRAUSCH ; E. SCHUIJERS.** Parametric Coding of stereo audio. *Eurasip, J. Applied Signal Proc.*, 2005, vol. 9, 1305-1322 [0008]
- **J. BREEBAART ; S. VAN DE PAR ; A. KOHLRAUSCH ; E. SCHUIJERS.** High-Quality Parametric Spatial Audio Coding at Low Bitrates. *AES 116th Convention*, May 2004 [0008]
- **E. SCHUIJERS ; J. BREEBAART ; H. PURNHAGEN ; J. ENGDEGARD.** Low Complexity Parametric Stereo Coding. *AES 116th Convention*, May 2004 [0008]