



(11) **EP 1 738 353 B1**

(12) **EUROPEAN PATENT SPECIFICATION**

(45) Date of publication and mention of the grant of the patent:
29.08.2007 Bulletin 2007/35

(21) Application number: **05797620.1**

(22) Date of filing: **28.10.2005**

(51) Int Cl.:
G10L 19/00^(2006.01)

(86) International application number:
PCT/EP2005/011587

(87) International publication number:
WO 2006/048204 (11.05.2006 Gazette 2006/19)

(54) **MULTI PARAMETRISATION BASED MULTI-CHANNEL RECONSTRUCTION**

AUF MEHRFACHPARAMETRISIERUNG BASIERENDE MEHRKANALREKONSTRUKTION
RECONSTRUCTION MULTICANAUX BASEE SUR UNE PARAMETRISATION MULTIPLE

(84) Designated Contracting States:
AT BE BG CH CY CZ DE DK EE ES FI FR GB GR HU IE IS IT LI LT LU LV MC NL PL PT RO SE SI SK TR

(30) Priority: **02.11.2004 SE 0402652**

(43) Date of publication of application:
03.01.2007 Bulletin 2007/01

(73) Proprietors:
• **Coding Technologies AB**
113 52 Stockholm (SE)
• **Koninklijke Philips Electronics N.V.**
5621 BA Eindhoven (NL)

(72) Inventors:
• **VILLEMOES, Lars**
S-113 52 Stockholm (SE)
• **KJÖRLING, Kristofer**
S-113 52 Stockholm (SE)
• **PURNHAGEN, Heiko**
S-113 52 Stockholm (SE)
• **RÖDEN, Jonas**
S-113 52 Stockholm (SE)
• **BREEBAART, Jeroen**
NL-5621 BA Eindhoven (NL)
• **HOTHO, Gerard**
NL-5621 BA Eindhoven (NL)

(74) Representative: **Zinkler, Franz et al**
Schoppe, Zimmermann, Stöckeler & Zinkler
Postfach 246
82043 Pullach bei München (DE)

(56) References cited:
EP-A- 1 376 538 **US-A1- 2002 067 834**

- **TENKATE W RTH: "COMPATIBILITY MATRIXING OF MULTICHANNEL BIT-RATE-REDUCED AUDIO SIGNALS" JOURNAL OF THE AUDIO ENGINEERING SOCIETY, AUDIO ENGINEERING SOCIETY, NEW YORK, NY, US, vol. 44, no. 12, December 1996 (1996-12), pages 1104-1119, XP000688688 ISSN: 1549-4950**
- **SZCZERBA M ET AL: "Matrixed multi-channel extension for AAC codec" AUDIO ENGINEERING SOCIETY CONVENTION PAPER 5796, 22 March 2003 (2003-03-22), - 25 March 2003 (2003-03-25) pages 1-9, XP002363660 Amsterdam**
- **HERRE J ET AL: "Spatial Audio Coding: Next-generation efficient and compatible coding of multi-channel audio" AUDIO ENGINEERING SOCIETY CONVENTION PAPER, NEW YORK, NY, US, 28 October 2004 (2004-10-28), pages 1-13, XP002343375**

Note: Within nine months from the publication of the mention of the grant of the European patent, any person may give notice to the European Patent Office of opposition to the European patent granted. Notice of opposition shall be filed in a written reasoned statement. It shall not be deemed to have been filed until the opposition fee has been paid. (Art. 99(1) European Patent Convention).

EP 1 738 353 B1

Description**TECHNICAL FIELD**

5 [0001] The present invention relates to multi-channel reconstruction of audio signals based on an available stereo signal and additional control data.

BACKGROUND OF THE INVENTION

10 [0002] Recent development in audio coding has made available the ability to recreate a multi-channel representation of an audio signal based on a stereo (or mono) signal and corresponding control data. These methods differ substantially from older matrix based solution such as Dolby Prologic, since additional control data is transmitted to control the re-creation, also referred to as up-mix, of the surround channels based on the transmitted mono or stereo channels.

15 [0003] Hence, the parametric multi-channel audio decoders reconstruct N channels based on M transmitted channels, where $N > M$, and the additional control data. The additional control data represents a significant lower data rate than transmitting the additional N-M channels, making the coding very efficient while at the same time ensuring compatibility with both M channel devices and N channel devices.

20 [0004] These parametric surround coding methods usually comprise a parameterisation of the surround signal based on IID (Inter channel Intensity Difference) and ICC (Inter Channel Coherence). These parameters describe power ratios and correlation between channel pairs in the up-mix process. Further parameters also used in prior art comprise prediction parameters used to predict intermediate or output channels during the up-mix procedure.

25 [0005] One of the most appealing usage of prediction based method as described in prior art is for a system that re-creates 5.1 channel from two transmitted channels. In this configuration a stereo transmission is available at the decoder side, which is a downmix of the original 5.1 multi-channel signal. In this context it is particularly interesting to be able to as accurately as possible extract the center channel from the stereo signal, since the center channel is usually downmixed to both the left and the right downmix channel. This is done by means of estimating two prediction coefficients describing the amount of each of the two transmitted channels used to build the center channel. These parameters are estimated for different frequency regions similarly to the IID and ICC parameters above.

30 [0006] However, since the prediction parameters do not describe a power ratio of two signals, but are based on wave-form matching in a least square error sense, the method becomes inherently sensitive to any modification of the stereo waveform after the calculation of the prediction parameters.

35 [0007] Further developments in audio coding over the recent years has introduced High Frequency Reconstruction methods as a very useful tool in audio codecs at low bitrates. One example is SBR (Spectral Band Replication) [WO 98/57436], that is used in MPEG standardized codecs such as MPEG-4 High Efficiency AAC. Common for these methods are that they re-create the high frequencies on the decoder side from a narrow-band signal coded by the underlying core-codec and a small amount of additional guidance information. Similar to the case of the parametric reconstruction of multi-channel signals based on one or two channels, the amount of control data required to re-create the missing signal components (in the case of SBR, the high frequencies), is significantly smaller than the amount of data that would be required to code the entire signal with a wave-form codec.

40 [0008] It should be understood however, that the re-created highband signal, is perceptually equal to the original highband signal, while the actual wave-form differs significantly. Furthermore, for wave-form coders coding stereo signals at low bitrate stereo pre-processing is commonly used, which means that a limitation on the side signal of the mid/side representation of the stereo signal is performed.

45 [0009] When a multi-channel representation is desired based on a stereo codec signal using MPEG-4 High Efficiency AAC or any other codec utilising high frequency reconstruction techniques, these and other aspects of the codec used to code the down-mixed stereo signal must be considered.

[0010] The article "Compatibility matrixing of multichannel bit-rate-reduced audio signals" (Ten Kate W R Th, Journal of the Audio Engineering Society, NY, US, vol. 44, no. 12, December 1996, pages 1104-1119) discloses variable matrixing: at each time frame the optimum matrix for minimum bit need is determined.

50 [0011] Even further, it is common that for a recording available as a multi-channel audio signal there is a dedicated stereo mix available, that is not an automated down-mix version of the multi-channel signal. This is commonly referred to as "artistic down-mix". This down-mix cannot be expressed as a linear combination of the multi-channel signals.

SUMMARY OF THE INVENTION

55 [0012] It is an object of the present invention to provide an improved multi-channel down-mix/encoder or up-mix/decoder concept, which results in a better quality of the reconstructed multi-channel output.

[0013] This object is achieved by a multi-channel synthesiser in accordance with claim 1, an encoder for processing

a multi-channel input signal in accordance with claim 18, a method of generating at least three output channels in accordance with claim 31, a method of processing in accordance with claim 32 or an encoded multi-channel signal in accordance with claim 33.

5 [0014] The present invention is based on the finding that different parametric representations for different frequency or time portions of a signal are useful for obtaining an encoding or decoding situation which is adapted to different situations. These situations can result from encoder events such as performing an SBR information calculation or an energy measure calculation used for energy loss compensation or any other event. Other situations which may result in different parametric representations can include the up-mix quality, the down-mix bit rate, the computational efficiency on the encoder side or on the decoder side or, for example, the energy consumption of e.g. battery-powered devices, so that, for a certain sub-band or frame, the first parameterisation is better than the second parameterisation. Naturally, 10 the target function can also be a combination of different individual targets/events as outlined above.

[0015] Preferably, one parametric representation includes parameters for a predictive upmix based on waveform modification of the down mixed multi-channel signal. This includes when the down-mixed signal is coded by a codec performing stereo-pre-processing, high frequency reconstruction and other coding schemes that significantly modify the waveform. Furthermore, the invention addresses the problem that arises when using predictive up-mix techniques for an artistic down-mix, i.e. a down-mix signal that is not automatically derived from the multi-channel signal. 15

[0016] Preferably, the present invention comprises the following features:

- Estimation of the prediction parameters based on the modified wave-form instead of the downmixed waveform; 20
- Using of prediction based methods only in the frequency ranges where it is advantageous;
- Correction of the energy loss and inaccurate correlation between channels introduced in the prediction based upmix procedure. 25

BRIEF DESCRIPTION OF THE DRAWINGS

[0017] The present invention will now be described by way of illustrative examples, not limiting the scope of the invention, with reference to the accompanying drawings, in which: 30

Fig. 1 illustrates a prediction based reconstruction of three channels from two channels;

Fig. 2 illustrates a predictive up-mix with energy compensation;

35 Fig. 3 illustrates an energy compensation in the predictive up-mix;

Fig. 4 illustrates a prediction parameter estimator on the encoder side with energy compensation of the down-mix signal;

40 Fig. 5 illustrates a predictive up-mix with correlation reconstruction;

Fig. 6 illustrates a mixing module for mixing the decorrelated signal with the up-mixed signal in the up-mix with correlation reconstruction;

45 Fig. 7 illustrates an alternative mixing module for mixing the decorrelated signal with the up-mixed signal in the up-mix with correlation reconstruction;

Fig. 8 illustrates prediction parameter estimation on the encoder side;

50 Fig. 9 illustrates prediction parameter estimation on the encoder side;

Fig. 10 illustrates an inventive multi-parameter scenario.

Fig. 11 illustrates an up-mixer device;

55 Fig. 12 illustrates an energy chart showing the result of an energy-loss introducing up-mix and the preferred compensation;

Fig. 13 a Table of energy compensation methods;

Fig. 14a a schematic diagram of a preferred multi-channel encoder;

5 Fig. 14b a flow chart of the method performed by the device of Fig. 14a;

Fig. 15a a multi-channel encoder having a spectral band replication functionality for generating a different parameterisation compared to the device in Fig. 14a;

10 Fig. 15b a tabular illustration of frequency-selective generation and transmission of parametric data; and

Fig. 16a a decoder illustrating the calculation of up-mix matrix coefficients;

Fig. 16b a detailed description of parameter calculation for the predictive up-mix;

15

Fig. 17 a transmitter and a receiver of a transmission system; and

Fig. 18 an audio recorder having an encoder and an audio player having a decoder.

20

DESCRIPTION OF PREFERRED EMBODIMENTS

[0018] The below-described embodiments are merely illustrative for the principles of the present invention. It is understood that modifications and variations of the arrangements and the details described herein will be apparent to others skilled in the art. It is the intent, therefore, to be limited only by the scope of the impending patent claims and not by the specific details presented by way of description and explanation of the embodiments herein.

25

[0019] It is emphasized that subsequent parameter calculation, application, upmixing, downmixing or any other actions can be performed on a frequency band selective base, i.e. for subbands in a filterbank.

[0020] In order to outline the advantages of the present invention a more detailed description of a predictive upmix as known by prior art is given first. Let's assume a three channel upmix based on two downmix channels, as outlined in Fig 1, where 101 represents the left original channel, 102 represents the *center* original channel, 103 represents the *right* original channel, 104 represents the down-mix and parameter extraction module on the encoder side, 105 and 106 represents prediction parameters, 107 represents the *left* down-mixed channel, 108 represents the *right* downmixed channel, 109 represents the predictive upmix module, and 110, 111 and 112 represents the reconstructed *left*, *center*, and *right* channel respectively.

30

[0021] Assume the following **definitions** where \mathbf{X} is a $3 \times L$ matrix containing the three signal segments $l(k)$, $r(k)$, $c(k)$, $k=0, \dots, L-1$ as rows.

35

[0022] Likewise, let the two downmixed signals $l_0(k)$, $r_0(k)$ form the rows of \mathbf{X}_0 . The downmix process is described by

40

$$\mathbf{X}_0 = \mathbf{D}\mathbf{X} \tag{1}$$

where the downmix matrix is defined by

45

$$\mathbf{D} = \begin{pmatrix} \alpha_1 & \alpha_2 & \alpha_3 \\ \beta_1 & \beta_2 & \beta_3 \end{pmatrix} \tag{2}$$

[0023] A preferred choice of downmix matrix is

50

$$\mathbf{D}_\alpha = \begin{pmatrix} 1 & 0 & \alpha \\ 0 & 1 & \alpha \end{pmatrix} \tag{3}$$

55

which means that the left downmix signal $l_0(k)$ will contain only $l(k)$ and $\alpha c(k)$, and $r_0(k)$ will contain only $r(k)$ and $\alpha c(k)$. This downmix matrix is preferred since it assigns an equal amount of the center channel to the left and right downmix, and since it does not assign any of the original right channel to the left downmix or vice versa.

[0024] The upmix is defined by

$$\hat{\mathbf{X}} = \mathbf{C}\mathbf{X}_0 \quad (4)$$

where \mathbf{C} is a 3×2 upmix matrix.

[0025] The predictive upmix as known from prior art relies on the idea of solving the overdetermined system

$$\mathbf{C}\mathbf{X}_0 = \mathbf{X} \quad (5)$$

for \mathbf{C} in the least squares sense. This leads to the normal equations

$$\mathbf{C}\mathbf{X}_0\mathbf{X}_0^* = \mathbf{X}\mathbf{X}_0^* \quad (6)$$

[0026] Multiplying (6) from the left with \mathbf{D} gives $\mathbf{D}\mathbf{C}\mathbf{X}_0\mathbf{X}_0^* = \mathbf{X}_0\mathbf{X}_0^*$, which, in the generic case where $\mathbf{X}_0\mathbf{X}_0^* = \mathbf{D}\mathbf{X}\mathbf{X}^*\mathbf{D}^*$ is non-singular, implies

$$\mathbf{D}\mathbf{C} = \mathbf{I}_2 \quad (7)$$

where, \mathbf{I}_n , denotes the n identity matrix. This relation reduces the parameter space \mathbf{C} to dimension two.

[0027] Given the above, the upmix matrix $\mathbf{C} = \begin{pmatrix} c_{11} & c_{12} \\ c_{21} & c_{22} \\ c_{31} & c_{32} \end{pmatrix}$ can be completely defined on the decoder side if the downmix matrix \mathbf{D} is known, and two elements of the \mathbf{C} matrix are transmitted, e.g. c_{11} and c_{22} .

[0028] The **residual** (prediction error) signals are given by

$$\mathbf{X}_r = \mathbf{X} - \hat{\mathbf{X}} = (\mathbf{I}_3 - \mathbf{C}\mathbf{D})\mathbf{X} \quad (8)$$

[0029] Multiplying from the left with \mathbf{D} yields

$$\mathbf{D}\mathbf{X}_r = (\mathbf{D} - \mathbf{D}\mathbf{C}\mathbf{D})\mathbf{X} = \mathbf{0} \quad (9)$$

due to (7). It follows that there is a $1 \times L$ row vector signal x_r such that

$$\mathbf{X}_r = \mathbf{v}x_r \quad (10)$$

where \mathbf{v} is a 3×1 unit vector spanning the kernel (null space) of \mathbf{D} . For instance, in the case of downmix (3), one can use

$$\mathbf{v} = \frac{1}{\sqrt{1+2\alpha^2}} \begin{bmatrix} -\alpha \\ -\alpha \\ 1 \end{bmatrix} \quad (11)$$

[0030] In general, when $\mathbf{v} = [v_f, v_r, v_d]^T$, and the $X[\hat{l}(k), \hat{r}(k), \hat{d}(k)]^T$ this just means that, up to a weight factor, the

residual signal is common for all three channels,

$$\begin{aligned}
 l(k) &= \hat{l}(k) + v_l x_r(k) \\
 r(k) &= \hat{r}(k) + v_r x_r(k) \\
 c(k) &= \hat{c}(k) + v_c x_r(k)
 \end{aligned}
 \tag{12}$$

[0031] Due to the orthogonality principle, the residual $x_r(k)$ is orthogonal to all three predicted signals $\hat{l}(k)$, $\hat{r}(k)$, $\hat{c}(k)$.

Problems solved and improvements obtained by preferred embodiments of the present invention

[0032] Evidently the following problems arise when using prediction based up-mix according to prior art as outlined above:

- The method relies on matching wave-form in a least mean square errors sense, which does not work for systems where the waveform of the downmixed signals are not maintained.
- The method does not provide the correct correlation structure between the reconstructed channels (as will be outlined below).
- The method does not re-construct the right amount of energy in the reconstructed channels.

Energy compensation

[0033] As mentioned above, one of the problems with prediction based multi-channel re-construction is that the prediction error corresponds to an energy loss of the three reconstructed channels. In the below, the theory for this energy loss and a solution as taught by preferred embodiments is outlined. Firstly, the theoretical analysis is performed, and subsequently a preferred embodiment of the present invention according to the below outlined theory is given.

[0034] Let E , \hat{E} , and E_r be the sum of the energies of the original signals in \mathbf{X} , the predicted signals in $\hat{\mathbf{X}}$ and the prediction error signals in \mathbf{X}_r , respectively. From orthogonality, it follows that

$$E = \hat{E} + E_r \tag{13}$$

[0035] The total *prediction gain* can be defined as $\rho = \frac{E}{\hat{E}}$ but in the following it will be more convenient to consider the parameter

$$\rho = \sqrt{\frac{\hat{E}}{E}} \tag{14}$$

[0036] Hence, $\rho^2 \in [0,1]$ measures the total relative energy of the predictive upmix.

Given this ρ , it is possible to readjust each channel by applying a compensation gain, $\hat{z}_g(k) = g_z \hat{z}(k)$, such that

$$\|\hat{z}_g\|^2 = \|z\|^2 \text{ for } z = l, r, c. \text{ Specifically, the target energy is given by (12),}$$

$$\|z\|^2 = \|\hat{z}\|^2 + v_z^2 \|x_r\|^2 \tag{15}$$

so we need to solve

$$g_z^2 \|\hat{z}\|^2 = \|\hat{z}\|^2 + v_z^2 \|x_r\|^2 \quad (16)$$

[0037] Here, since v is a unit vector,

$$E_r = \|x_r\|^2, \quad (17)$$

and it follows from the definition (14) of ρ and (13) that

$$E_r = \frac{1-\rho^2}{\rho} \hat{E}, \quad (18)$$

[0038] Putting all this together, we arrive at the gain

$$g_z = \left(1 + v_z^2 \frac{1-\rho^2}{\rho^2} \frac{\hat{E}}{\|\hat{z}\|^2} \right)^{1/2}, \quad (19)$$

[0039] It is evident that with this method, in addition to transmitting ρ , the energy distribution of the decoded channels has to be computed at the decoder. Moreover only the energies are reconstructed correctly, while the off diagonal correlation structure is ignored.

[0040] It is possible to derive a gain value that ensures that the total energy is preserved, while not ensuring that the energy of the individual channels are correct. A common gain for all channels $g_z = g$ that ensures that the total energy is preserved is obtained via the defining equation $g^2 \hat{E} = E$. That is,

$$g = \frac{1}{\rho}, \quad (20)$$

[0041] By linearity, this gain can be applied in the encoder to the downmixed signals, so that no additional parameter has to be transmitted.

[0042] Fig 2. outlines a preferred embodiment of the present invention that re-creates the three channels while maintaining the correct energy of the output channels. The downmixed signals l_0 and r_0 are input to the upmix module 201, along with the prediction parameters c_1 and c_2 . The upmix module re-creates the upmix matrix C based on knowledge about the downmix matrix D and the received prediction parameters. The three output channels from 201 are input to 202 along with the adjustment parameter ρ . The three channels are gain adjusted as a function of the transmitted parameter ρ and the energy corrected channels are output.

[0043] In Fig. 3 a more detailed embodiment of the adjustment module 202 is displayed. The three up-mixed channels are input to adjustment module 304, as well as to module 301, 302 and 303 respectively. The energy estimation modules 301 - 303 estimates the energy of the three up-mixed signals and inputs the measured energy to adjustment module 304. The control signal ρ (representing the prediction gain) received from the encoder is also input to 304. The adjustment module implements equation (19) as outlined above.

[0044] In an alternative implementation of the present invention the energy correction can be done on the encoder side. Fig. 4 illustrates an implementation of the encoder where the downmixed signals l_0 107 and r_0 108 are gain adjusted by 401 and 402 according to a gain value calculated by 403. The gain value is derived according to equation (20) above. As outlined above it is an advantage of this embodiment of the present invention, since it is not necessary to calculate the energy of the three re-created channels from the predictive up-mix. However, this only ensures that the total energy

of the three re-created channels is correct. It does not ensure that the energy of the individual channels are correct.

[0045] A preferred example for a down-mixing matrix corresponding to equation (3) is noted below the down-mixer in Fig. 4. However, the down-mixer can apply any general down-mix matrix as outlined in equation (2).

[0046] As will be outlined later on, for the present case of a down-mixer having, as an input, three channels, and, having, as an output, two channels, two additional up-mix parameters c_1, c_2 are at least required. When a down-mixing matrix D is variable or not fully known to a decoder, also additional information on the used down-mix has to be transmitted from the encoder-side to a decoder-side, in addition to the parameters 105 and 106.

Correlation structure

[0047] One of the problems with the up-mix procedure described by prior art is that it does not re-construct the correct correlation between the re-created channels. Since, as was outlined above, the centre channel is predicted as a linear combination of the left down-mix channel and the right down-mix channel, and the left and right channels are re-constructed by subtracting the predicted center channel from the left and right down-mix channels. It is evident that the prediction error will result in remains of the original center channel in the predicted left and right channel. This implies that the correlations between the three channels are not the same for the reconstructed channels as it was for the original three channels.

[0048] A preferred embodiment teaches that the predicted three channels should be combined with de-correlated signals in accordance with the measured prediction error.

[0049] The basic theory for achieving the correct correlation structure is now outlined. The special structure of the residual can be used to reconstruct the full 3×3 correlation structure $\mathbf{X}\mathbf{X}^*$ by substituting a de-correlated signal x_d for the residual in the decoder.

[0050] First, note that the normal equations (6) lead to $\mathbf{X}_r \mathbf{X}_0^* = \mathbf{0}$ so

$$\mathbf{X}_r \hat{\mathbf{X}}^* = \mathbf{0}, \quad \hat{\mathbf{X}} \mathbf{X}_r^* = \mathbf{0} \tag{21}$$

[0051] Hence, as $\mathbf{X} = \hat{\mathbf{X}} + \mathbf{X}_r$,

$$\mathbf{X}\mathbf{X}^* = \hat{\mathbf{X}}\hat{\mathbf{X}}^* + \mathbf{X}_r \mathbf{X}_r^* = \hat{\mathbf{X}}\hat{\mathbf{X}}^* + \mathbf{v}\mathbf{v}^* E_r \tag{22}$$

where (10) and (17) were applied for the last equality.

[0052] Let x_d be a signal de-correlated from all decoded signals $\hat{l}, \hat{r}, \hat{c}$ such that $\hat{\mathbf{X}} x_d^* = \mathbf{0}$. The enhanced signal

$$\mathbf{Y} = \hat{\mathbf{X}} + \mathbf{v}x_d \tag{23}$$

then has the correlation matrix

$$\mathbf{Y}\mathbf{Y}^* = \hat{\mathbf{X}}\hat{\mathbf{X}}^* + \mathbf{v}\mathbf{v}^* \|x_d\|^2 \tag{24}$$

[0053] In order to completely reproduce the original correlation matrix (22), it suffices that

$$\|x_d\|^2 = E_r \tag{25}$$

[0054] If x_d is obtained by de-correlating the downmixed signal, say $\frac{1}{2}(l_0 + r_0)$, followed by a gain γ then it should hold that

$$\gamma^2 \left\| \frac{1}{2}(l_0 + r_0) \right\|^2 = E_r \quad (26)$$

[0055] This gain can be computed in the encoder. However, if the more well-defined parameter $\rho^2 \in [0,1]$ from (14) is to be used, estimation of \hat{E} and $\left\| \frac{1}{2}(l_0 + r_0) \right\|^2$ has to be performed in the decoder. In light of this, a more attractive alternative is to generate x_d using three decorrelators

$$x_d = \gamma \cdot (d_1 \{\hat{l}\} + d_2 \{\hat{r}\} + d_3 \{\hat{c}\}) \quad (26a)$$

since then $\|x_d\|^2 = \gamma^2 \hat{E}$, so (25) is satisfied by the choice

$$\gamma = \sqrt{\frac{1}{\rho^2} - 1}. \quad (27)$$

[0056] Fig. 5 illustrates one embodiment of the present invention for predictive up-mix of three channels from two down-mix channels, while maintaining the correct correlation structure between the channels. In Fig. 5 module 109, 110, 111 and 112 are the same as in Fig. 1 and will not be elaborated further on here. The three up-mixed signals that are output from 109 are input to de-correlation modules 501, 502 and 503. These generate mutually de-correlated signals. The de-correlated signals are summed and input to the mixing modules 504, 505 and 506, where they are mixed with the output from 109. The mixing of the predictive up-mixed signals with de-correlated versions of the same is an essential feature of the present invention. In Fig. 6 one embodiment of the mixing modules 504, 505 and 506 is displayed. In this embodiment of the invention the level of the de-correlated signal is adjusted by 601 based on the control signal γ . The de-correlated signal is subsequently added to the predictive up-mixed signal in 602.

[0057] A third preferred embodiment uses decorrelators 501, 502, 503 for the up-mixed channels. A de-correlated signal can also be generated by a de-correlator 501', which receives, as an input signal, the down-mix channel or even all down-mix channels. Furthermore, in case of more than one down-mix channel, as shown in Fig. 5, the de-correlation signal can also be generated by separate de-correlators for the left base channel l_0 and the right base channel r_0 and by combining the output of these separate de-correlators. This possibility is substantially the same as the possibility shown in Fig. 5, but has a difference to the possibility shown in Fig. 5 in that the base channels before up-mixing are used.

[0058] Furthermore, it is outlined in connection with Fig. 5 that the mixing modules 504, 505 and 506 do not only receive the factor γ , which is equal for all three channels, since this factor only depends on the energy measure ρ , but also receive the channel-specific factor v_1 , v_c and v_r , which is determined as outlined in connection with equations (10) and (11). This parameter, however, does not have to be transmitted from an encoder to a decoder, when the decoder knows the down-mix used at the encoder. Instead, these parameters in the matrix \mathbf{v} as shown in equation (10) and (11) are preferably pre-programmed into the mixing modules 504, 505, and 506 so that these channel-specific weighting factors do not have to be transmitted (but can of course be transmitted when required).

[0059] In Fig. 6, it is shown that the weighting device 601 adjusts the energy of the de-correlated signal using the product of γ and the channel-specific down-mix-dependent parameter v_z , wherein z stands for l , r or c . In this context, it is noted that equation (26a) makes sure that the energy of x_d is equal to the sum energy of the predictively up-mixed left, right and centre channels. Therefore, device 601 can simply be implemented as a scaler using the scaling factor G_l . When, however, the de-correlated signal is generated alternatively, the mixing module 504, 505, 506 has to perform an absolute energy adjustment of the de-correlated signal added by adding device 602 so that the energy of the signal added at adder 602 is equal to the energy of the residual signal, e.g., the energy, which is lost by the non-energy

preserving predictive up-mix.

[0060] Regarding the channel-specific down-mix-dependent parameter v_z , the same remarks as outlined above with respect to Fig. 6 also apply for the Fig. 7 embodiment.

[0061] Furthermore, it is to be noted here that the Fig. 6 and Fig. 7 embodiment are based on the recognition that at least a part of the energy lost in the predictive up-mixing is added using a de-correlation signal. In order to have correct signal energies and correct portions of the dry signal component (un-correlated) signal and the "wet" signal component (de-correlated), it is to be made sure that the "dry" signal input into the mixing module 504 is not pre-scaled. When, for example, the base channels have been pre-corrected on the de-decoder-side (as shown in Fig. 4) then this pre-correction of Fig. 4 has to be compensated for by multiplying the channel by the (relative) energy measure ρ before inputting the channel into the mixer box 504, 505 or 506. Additionally, the same procedure has to be done, when such an energy correction has been performed on a decoder-side before entering the down-mix channels into the up-mixer 109 as shown in Fig. 5.

[0062] When only a part of the residual energy is to be covered by a de-correlated signal, pre-correction only has to be partly removed by pre-scaling the signal input into the mixing box 504, 505, 506 by a ρ -dependent factor, which is, however, closer to one than the factor ρ itself. Naturally, this partly-compensating pre-scaling factor will depend on the encoder-generated signal κ input at 605 in Fig. 7. When such a partly pre-scaling has to be performed, then the weighting factor applied in G_2 is not necessary. Instead, then the branch from input 604 to the summer 602 will be the same as in Fig. 6.

Controlling the degree of decorrelation

[0063] A preferred embodiment of the invention teaches that the amount of de-correlation added to the predicted up-mixed signals can be controlled from the encoder, while still maintaining the correct output energy. This is since in a typical "interview" example of dry speech in the center channel and ambience in the left and right channels, the substitution of de-correlated signal for prediction error in the center channel may be undesirable.

[0064] According to a preferred embodiment of the present invention an alternative mixing procedure to the one outlined in Fig. 5 can be used. It will be shown below how according to the present invention the issues of total energy preservation and true correlation reproduction can be separated and the amount of de-correlation can be controlled by the parameter K .

[0065] We will assume that a total energy preserving gain compensation (20) has been performed on the downmixed signal, so that we first obtain the decoded signal \hat{X}/ρ . From this, a decorrelated signal d with same total energy $\|d\|^2 = \hat{E}/\rho^2$ is produced, for instance by use of three decorrelators as in the previous section. The total upmix is then defined according to

$$Y_x = \kappa \cdot \frac{1}{\rho} \hat{X} + \sqrt{1 - \kappa^2} \cdot v d . \quad (29)$$

where $\kappa \in [\rho, 1]$ is a transmitted parameter. The choice $\kappa = 1$ corresponds to total energy preservation without decorrelated signal addition and $\kappa = \rho$ corresponds to full 3×3 correlation structure reproduction. We have

$$Y_x Y_x^* = \frac{\kappa^2}{\rho^2} \hat{X} \hat{X}^* + \frac{1 - \kappa^2}{\rho^2} v v^* \hat{E} , \quad (30)$$

so the total energy is preserved for all $\kappa \in [\rho, 1]$, as it can be seen by computing the traces (sum of diagonal values) of the matrices in (30). However, correct individual energy is only obtained for $\kappa = \rho$.

[0066] Fig 7 illustrates an embodiment of the mixing modules 504, 505 and 506 of Fig. 5 according to the theory outlined above. In this alternative of the mixing modules the control parameter γ is input to 702 and 701. The gain factor used for 702 corresponds to κ according to equation (29) above, and the gain factor used for 701 corresponds to

$\sqrt{1 - \kappa^2}$ according to equation (29) above.

[0067] The above described embodiment of the present invention, allows the system to employ a detection mechanism on the encoder side, that estimates the amount of de-correlation to be added in the prediction based up-mix. The implementation described in Fig. 7 will add the indicated amount of de-correlated signal, and apply energy correction

so that the total energy of the three channels is correct, while still being able to replace an arbitrary amount of the prediction error by de-correlated signal.

[0068] This means that for an example with three ambient signals, e.g. a classical music piece, with a lot of ambience, the encoder can detect the lack of a "dry" center channel, and let the decoder replace the entire prediction error with de-correlated signal, thus re-creating the ambience of the sound from the three channels in a way that would not be possible with prior-art prediction based methods alone. Furthermore, for a signal with a dry center channel, e.g. speech in the center channel and ambient sounds in the left and right channels, the encoder detects that replacing the prediction error by de-correlated signal is not psycho-acoustically correct and instead let the decoder adjust the levels of the three reconstructed channels so that the energy of the three channels is correct. Obviously the extreme examples above represents two possible outcomes of the invention. It is not limited to cover just the extreme cases outlined in the above examples.

Adapting the prediction coefficients to modified waveforms.

[0069] As outlined above the prediction parameters are estimated by minimising the mean square error given the original three channels **X** and a downmix matrix **D**. However, in many situations it cannot be relied upon that the downmixed signal can be described as a downmix matrix **D** multiplied by a matrix **X** describing the original multichannel signal.

One obvious example for this is when a so called "artistic downmix" is used, i.e. the two channel downmix can not be described as a linear combination of the multichannel signal. Another example is when the downmixed signal is coded by a perceptual audio codec that utilises stereo-pre processing or other tools for improved coding efficiency. It is commonly known in prior art that many perceptual audio codecs rely on mid/side stereo coding, where the side signal is attenuated under bitrate constrained condition, yielding an output that has a narrower stereo image than that of the signal used for encoding.

[0070] Fig 8 displays a preferred embodiment of the present invention where the parameter extraction on the encoder side apart from the multi-channel signal also has access to the modified downmix signal. The modified down-mix is here generated by 801. If only two parameters of the **C** matrix are transmitted, a knowledge of the **D** matrix on the decoder side is needed in order to be able to do the up-mix, and get the least mean square error for all up-mixed channels. However, the present embodiment teaches that you can replace the downmixed signals l_0 and r_0 on the encoder side by the downmixed signals l'_0 and r'_0 that are obtained by using a downmix matrix **D** that is not necessarily the same as that assumed on the decoder. Using the alternative downmix for parameter estimation on the encoder side only guarantees a correct center channel reproduction at the decoder side. By transmitting additional information from the encoder to the decoder a more accurate up-mix of the three channels can be obtained. In one extreme case all six elements of the **C** matrix can be transmitted. However, the present embodiment teaches that a subset of the **C** matrix can be transmitted if it is accompanied with information on the downmix matrix **D** used 802.

[0071] As mentioned earlier perceptual audio codecs employ mid/side coding for stereo coding at low bitrates. Furthermore, stereo pre-processing is commonly employed in order to reduce the energy of the side signal under bitrate constrained conditions. This is done based on the psycho acoustical notion that for a stereo signal reduction of the width of the stereo signal is a preferred coding artifact over audible quantisation distortion and bandwidth limitation.

[0072] Hence, if a stereo pre-processing is used, the down-mix equation (3), can be expressed as

$$\mathbf{D}'_{\alpha} = \begin{pmatrix} 1-\gamma & \gamma \\ \gamma & 1-\gamma \end{pmatrix} \begin{pmatrix} 1 & 0 & \alpha \\ 0 & 1 & \alpha \end{pmatrix} \quad (31)$$

where γ is the attenuation of the side signal. As outlined earlier the **D** matrix needs to be known on the decoder side in order to correctly be able to reconstruct the three channels. Hence, the present embodiment teaches that the attenuation factor should be sent to the decoder.

[0073] Fig. 9 displays another embodiment of the present invention where the downmix signal l_0 and r_0 output from 104 is input to a stereo pre-processing device 901 that limits the side signal ($l_0 - r_0$) of the mid/side representation of the downmix signal by a factor γ . This parameter is transmitted to the decoder.

Parameterisation for HFR codec signals

[0074] If the prediction based upmix is used with High Frequency Reconstruction methods such as SBR [W0 98/57436], the prediction parameters estimated on the encoder side will not match the re-created high band signal on the decoder side. The present embodiment teaches the use of an alternative non-wave form based up-mix structure for re-creation

of three channels from two. The proposed up-mix procedure is designed to re-create the correct energy of all up-mixed channels in case of un-correlated noise signals.

[0075] Assuming that the downmix matrix \mathbf{D}_α as defined in (3) is used. And that we now will define the upmix matrix \mathbf{C} . Then the upmix is defined by

5

$$\hat{\mathbf{X}} = \mathbf{C}\mathbf{X}_0 \quad (32)$$

10 [0076] Striving at only re-creating the correct energy of the up-mixed signal $l(k)$, $r(k)$, and $c(k)$, where the energies are L , R and C , the up-mix matrix is chosen so that the diagonal elements of $\hat{\mathbf{X}}\hat{\mathbf{X}}^*$ and $\mathbf{X}\mathbf{X}^*$ are the same, according to:

15

$$\mathbf{X}\mathbf{X}^* = \begin{pmatrix} L & 0 & 0 \\ 0 & R & 0 \\ 0 & 0 & C \end{pmatrix}. \quad (35)$$

20 [0077] The corresponding expression for the downmix matrix will be

25

$$\mathbf{X}_0\mathbf{X}_0^* = \begin{pmatrix} L + \alpha^2 C & \alpha^2 C \\ \alpha^2 C & R + \alpha^2 C \end{pmatrix}, \quad (36)$$

30

$$\hat{\mathbf{X}}\hat{\mathbf{X}}^* = \mathbf{C}\mathbf{X}_0\mathbf{X}_0^*\mathbf{C}^* = \begin{pmatrix} c_{11} & c_{12} \\ c_{21} & c_{22} \\ c_{31} & c_{32} \end{pmatrix} \begin{pmatrix} L + \alpha^2 C & \alpha^2 C \\ \alpha^2 C & R + \alpha^2 C \end{pmatrix} \begin{pmatrix} c_{11} & c_{21} & c_{31} \\ c_{12} & c_{22} & c_{32} \end{pmatrix}. \quad (37)$$

35

[0078] Setting the diagonal element of $\hat{\mathbf{X}}\hat{\mathbf{X}}^*$ equal to the diagonal element of $\mathbf{X}\mathbf{X}^*$ translates to three equations defining the relation between the elements in \mathbf{C} and L , R and C

40

$$\begin{cases} Lc_{11}^2 + Rc_{12}^2 + C\alpha^2(c_{11} + c_{12})^2 = L \\ Lc_{21}^2 + Rc_{22}^2 + C\alpha^2(c_{21} + c_{22})^2 = R \\ Lc_{31}^2 + Rc_{32}^2 + C\alpha^2(c_{31} + c_{32})^2 = C \end{cases} \quad (38)$$

45

[0079] Based on the above an up-mix matrix can be defined. It is preferable to define an up-mix matrix that does not add the right down-mixed channel to the left up-mixed channel and vice versa. Hence, a suitable up-mix matrix may be

50

$$\mathbf{C} = \begin{pmatrix} \beta & 0 \\ 0 & \gamma \\ \delta & \delta \end{pmatrix} \quad (39)$$

[0080] This gives a C matrix according to:

55

$$\mathbf{C} = \begin{pmatrix} \sqrt{\frac{L}{L+\alpha^2 C}} & 0 \\ 0 & \sqrt{\frac{R}{R+\alpha^2 C}} \\ \sqrt{\frac{C}{L+R+4\alpha^2 C}} & \sqrt{\frac{C}{L+R+4\alpha^2 C}} \end{pmatrix} \quad (40)$$

[0081] It can be shown that the elements of the \mathbf{C} matrix can be re-created on the decoder side from the two transmitted

parameters $c_1 = \frac{L+R}{C}$ and $c_2 = \frac{L}{R}$.

[0082] Fig 10 outlines a preferred embodiment of the present invention. Here 101 - 112 are the same as in Fig. 1 and will not be elaborated on further here. The three original signals 101 - 103 are input to the estimation module 1001. This

module estimates two parameters, e.g. $c_1 = \frac{L+R}{C}$ and $c_2 = \frac{L}{R}$ from which the \mathbf{C} matrix can be derived on the

decoder side. These parameters along with the parameters output from 104 are input to selection module 1002. In one preferred embodiment, the selection module 1002 outputs the parameters from 104 if the parameters correspond to a frequency range that is coded by a wave-form codec, and outputs the parameters from 1001 if the parameters correspond to a frequency range reconstructed by HFR. The selection module 1002 also outputs information 1005 on which parameterisation is used for the different frequency ranges of the signal.

[0083] On the decoder side the module 1004 takes the transmitted parameters and directs them to the predictive up-mix 109 or the energy-based up-mix 1003 according to the above, dependent on the indication given by the parameter 1005. The energy based up-mix 1003 implements the up-mix matrix \mathbf{C} according to equation (40).

[0084] The upmix matrix \mathbf{C} as outlined in equation (40) has equal weights (δ) to obtain the estimated (decoder) signal $c(k)$ from the two downmixed signals $l_0(k)$, $r_0(k)$. Based on the observation that the relative amount of the signal $c(k)$ may differ in the two downmixed signals $l_0(k)$, $r_0(k)$ (i.e., C/L not equal to C/R), one could also consider the following generic upmix matrix:

$$\mathbf{C} = \begin{pmatrix} f_1(c_1, c_2) & f_2(c_1, c_2) \\ f_2(c_2, c_1) & f_1(c_2, c_1) \\ f_3(c_1, c_2) & f_3(c_2, c_1) \end{pmatrix} \quad (41)$$

[0085] In order to estimate $c(k)$, this embodiment also requires transmission of two control parameters c_1 and c_2 , which are for example equal to $c_1 = \alpha^2 C / (L + \alpha^2 X)$ and $c_2 = \alpha^2 X / (R + \alpha^2 C)$. A possible implementation of the upmix matrix functions f_i is then given by

$$f_1(c_1, c_2) = \sqrt{1 - c_1^2} \quad (42)$$

$$f_2(c_1, c_2) = 0 \quad (43)$$

$$f_3(c_1, c_2) = \frac{c_1}{2\alpha} \quad (44)$$

[0086] The signalling of the different parameterisation for the SBR range according to the present invention is not limited to SBR. The above outlined parameterisation can be used in any frequency range where the prediction error of the prediction based up-mix is deemed too large. Hence, module 1002 may output the parameters from 1001 or 104 dependent on a multitude of criteria, such as coding method of the transmitted signals, prediction error etc.

5 **[0087]** A preferred method for improved prediction based multi-channel reconstruction includes, at the encoder side, extracting different multi-channel parameterisations for different frequency ranges, and, at the decoder side, applying these parameterisations to the frequency ranges in order to re-construct the multi-channels.

10 **[0088]** A further preferred embodiment of the present invention includes a method for improved prediction based multi-channel reconstruction including, at the encoder side, extracting information on the down-mix process used and subsequently sending this information to a decoder, and, at the decoder side, applying an up-mix based on extracted prediction parameters and the information on the down-mix in order to reconstruct the multi-channels.

[0089] A further preferred embodiment of the present invention includes a method for improved prediction based multi-channel reconstruction, in which, at the encoder side, the energy of the down-mix signal is adjusted in accordance with a prediction error obtained for the extracted predictive up-mix parameters.

15 **[0090]** A further preferred embodiment of the present invention relates to a method for improved prediction based multi-channel reconstruction, in which, at the decoder side, an energy lost due to the prediction error is compensated for by applying a gain to the up-mixed channels.

[0091] A further embodiment of the present invention relates to a method for improved prediction based multi-channel reconstruction, in which, at the decoder side, the energy lost due to a prediction error is replaced by a de-correlated signal.

20 **[0092]** A further preferred embodiment of the present invention relates to a method for improved prediction based multi-channel reconstruction, in which, at the decoder side, a part of the energy lost due to a prediction error is replaced by a de-correlated signal, and a part of the energy lost is replaced by applying a gain to the up-mixed channels. This part of the energy lost is preferably signalled from an encoder.

25 **[0093]** A further preferred embodiment of the present invention is an apparatus for improved prediction based multi-channel reconstruction comprising means for adjusting the energy of the down-mix signal in accordance with the prediction error obtained for the extracted predictive up-mix parameters.

[0094] A further preferred embodiment of the present invention is an apparatus for improved prediction based multi-channel reconstruction comprising means for compensating for the energy loss due to the prediction error by applying a gain to the up-mixed channels.

30 **[0095]** A further preferred embodiment of the present invention is an apparatus for improved prediction based multi-channel reconstruction comprising means for replacing the energy lost due to the prediction error by a de-correlated signal.

[0096] A further preferred embodiment of the present invention is an apparatus for improved prediction based multi-channel reconstruction comprising means for replacing part of the energy lost due to the prediction error by a de-correlated signal, and part of the energy lost by applying a gain to the up-mixed channels.

35 **[0097]** A further preferred embodiment of the present invention is an encoder for improved prediction based multi-channel reconstruction including adjusting the energy of the down-mix signal in accordance with the prediction error obtained for the extracted predictive up-mix parameters.

[0098] A further preferred embodiment of the present invention is a decoder for improved prediction based multi-channel reconstruction including compensating for an energy loss due to the prediction error by applying a gain to the up-mixed channels.

40 **[0099]** A further preferred embodiment of the present invention relates to a decoder for improved prediction based multi-channel reconstruction including replacing the energy lost due to the prediction error by a de-correlated signal.

[0100] A further preferred embodiment of the present invention is a decoder for improved prediction based multi-channel reconstruction including replacing a part of the energy lost due to the prediction error by a de-correlated signal, and a part of the energy lost by applying a gain to the down-mixed channels.

45 **[0101]** Fig. 11 shows a multi-channel synthesiser for generating at least three output channels 1100 using an input signal having at least one base channel 1102, the at least one base channel being derived from an original multi-channel signal. The multi-channel synthesiser as shown in Fig. 11 includes an up-mixer device 1104, which can be implemented as shown in any of the Figures 2 to 10. Generally, the up-mixer device 1104 is operable to up-mix the at least one base channel using an up-mixing rule so that the at least three output channels are obtained. The up-mixer 1104 is operative to generate the at least three output channels in response to an energy measure 1106 and at least two different up-mixing parameters 1108 using an energy-loss introducing up-mixing rule so that the at least three output channels have an energy, which is higher than an energy of signals resulting from the energy-loss introducing up-mixing rule alone. Thus, irrespective of an energy error depending on the energy-loss introducing up-mixing rule, the invention results in an energy compensated result, wherein the energy compensation can be done by scaling and/or addition of a decorrelated signal. The at least two different up-mixing parameters 1108, and the energy measure 1106 are included in the input signal.

50 **[0102]** Preferably, the energy measure is any measure related to an energy loss introduced by the upmixing rule. It can be an absolute measure of the upmix-introduced energy error or the energy of the upmix signal (which is normally

lower in energy than the original signal), or it can be a relative measure such as a relation between the original signal energy and the upmix signal energy or a relation between the energy error and the original signal energy or even a relation between the energy error and the upmix signal energy. A relative energy measure can be used as a correction factor, but nevertheless is an energy measure since it depends on the energy error introduced into the upmix signal generated by an energy-loss introducing upmixing rule or - stated in other words - a non-energy-preserving upmixing rule.

[0103] An exemplary energy-loss introducing upmixing rule (non-energy-preserving upmixing rule) is an upmix using transmitted prediction coefficients. In case of a non-perfect prediction of a frame or subband of a frame, the upmix output signal is affected by a prediction error, corresponding to an energy loss. Naturally, the prediction error varies from frame to frame, since in case of an almost perfect prediction (a low prediction error) only a small compensation (by scaling or adding a decorrelated signal) has to be done while in case of a larger prediction error (a non-perfect prediction) more compensation has to be done. Therefore, the inventive energy measure also varies between a value indicating no or only a small compensation and a value indicating a large compensation.

[0104] When the energy measure is considered as an InterChannel Coherence (ICC) value, which consideration is natural, when the compensation is done by adding a decorrelated signal scaled depending on the energy measure, the preferably used relative energy measure (p) varies typically between 0.8 and 1.0, wherein 1.0 indicates that the upmixed signals are decorrelated as required or that no decorrelated signal has to be added or that the energy of the predictive upmix result is equal to the energy of the original signal or that the prediction error is zero.

[0105] However, the present invention is also useful in connection with other energy-loss introducing upmixing rules, i.e. rules that are not based on waveform matching but that are based on other techniques, such as the use of codebooks, spectrum matching, or any other upmixing rules that do not care for energy preservation.

[0106] Generally, the energy compensation can be performed before or after applying the energy-loss introducing upmixing rule. Alternatively, the energy loss compensation can even be included into the upmixing rule such as by altering the original matrix coefficients using the energy measure so that a new upmixing rule is generated and used by the upmixer. This new upmixing rule is based on the energy-loss introducing upmixing rule and the energy measure. Stated in other words, this embodiment is related to a situation in which the energy compensation is "mixed" into the "enhanced" upmixing rule so that the energy compensation and/or the addition of a decorrelated signal are performed by applying one or more upmixing matrices to an input vector (the one or more base channel) to obtain (after the one or more matrix operations) the output vector (the reconstructed multi-channel signal having at least three channels).

[0107] Preferably, the up-mixer device receives two base channels l_0 , r_0 and outputs three re-constructed channels 1, r and c.

[0108] Subsequently, reference is made to Fig. 12 to show an example energy situation at different positions on an encoder-decoder-path. Block 1200 shows an energy of a multi-channel audio signal such as a signal having at least a left channel, a right channel and a centre channel as shown in Fig. 1. For the embodiment in Fig. 12, it is assumed that the input channels 101, 102, 103 in Fig. 1 are completely uncorrelated, and that the down-mixer is energy-preserving. In this case, the energy of the one or more base channels indicated by block 1202 is identical to the energy 1200 of the multi-channel original signal. When the original multi-channel signals are correlated to each other, the base channel energy 1202 can be lower than the energy of the original multi-channel signal, when, for example, the left and the right (partly) cancel each other.

[0109] For the subsequent discussion, however, it is assumed that the energy 1202 of the base channels is the same as the energy 1200 of the original multi-channel signal.

[0110] 1204 illustrates the energy of the up-mix signals, when the up-mix signals (e.g., 110, 111, 112 of Fig. 1) are generated using a non-energy preserving up-mix or a predictive up-mix as discussed in connection with Fig. 1. Since, as will be outlined later with respect to Fig. 14a, and 14b, such a predictive up-mix introduces an energy error E_p , the energy 1204 of the up-mix result will be lower than the energy of the base channels 1202.

[0111] The up-mixer 1104 is operative to output output channels, which have an energy, which is higher than the energy 1204. Preferably, the up-mixer device 1104 performs a complete compensation so that the up-mix result 1100 in Fig. 11 has an energy as shown at 1206.

[0112] Preferably, the up-mix result, the energy of which is shown at 1204, is not simply up-scaled as shown in Fig. 2, or individually up-scaled as shown in Fig. 3 or encoder-side up-scaled as shown in Fig. 4. Instead, the remaining energy E_p , which corresponds to the error due to the predictive up-mix is "filled up" using a de-correlated signal. In another preferred embodiment, this energy error E_p is only partly covered by a de-correlated signal, while the rest of the energy error is made up by up-scaling the up-mix result. The complete covering of the energy error by a de-correlated signal is shown in Fig. 5 and Fig. 6, while the "in-part"-solution is illustrated by Fig. 7.

[0113] Fig. 13 shows a plurality of energy-compensation methods, e.g., methods, which have in common the feature that, based on an energy measure which depends on the energy error, the energy of the output channels is higher than the pure result of the predictive up-mix, i.e., the result of the (not-corrected) energy-loss introducing upmixing rule.

[0114] Number 1 of the Table in Fig. 13 relates to the decoder-side energy compensation, which is performed subsequent to the up-mix. This option is shown in Fig. 2 and is, additionally, further elaborated in connection with Fig. 3,

which shows the channel-specific up-scaling factors g_z , which not only depend on the energy measure ρ , but which, additionally, depend on the channel-dependent down-mix factors v_z , wherein z stands for 1, r or c.

[0115] Number 2 of Fig. 13 includes the encoder-side energy compensation method, which is performed subsequent to the down-mix, which is illustrated in Fig. 4. This embodiment is preferable in that the energy measure ρ does not have to be transmitted from the encoder to the decoder.

[0116] Number 3 of the Table in Fig. 13 relates to the decoder-side energy compensation, which is performed before the up-mix. When Fig. 2 is considered, the energy correction 202, which is performed after the up-mix in Fig. 2 would be performed before the up-mix block 201 in Fig. 2. This embodiment results, compared to Fig. 2, in an easier implementation, since no channel-specific correction factors as shown in Fig. 3 are required, although quality losses might occur.

[0117] Number 4 of Fig. 13 relates to a further embodiment, in which an encoder-side correction is performed before down-mixing. When Fig. 1 is considered, channels 101, 102, 103 would be up-scaled by a corresponding compensation factor so that the down-mixer output is increased after down-mixing as shown at 1208 in Fig. 12. Thus, the number four embodiment in Fig. 13 has the same consequence for the base channels' output by an encoder as the number two embodiment of the present invention.

[0118] Number 5 of the Fig. 13 Table relates to the embodiment in Fig. 5, when the de-correlated signal is derived from the channels generated by the non-energy preserving up-mixing rule 109 in Fig. 5.

[0119] The number 6 embodiment in the Table in Fig. 13 relates to the embodiment, in which only part of the residual energy is covered by the de-correlated signal. This embodiment is illustrated in Fig. 7.

[0120] The number 8 embodiment of Fig. 13 is similar to the number 5 or 6 embodiment, but the de-correlated signal is derived from the base channels before up-mixing as outlined by box 501' in Fig. 5.

[0121] Subsequently, a preferred embodiment of the encoder is described in detail. Fig. 14a illustrates an encoder for processing a multi-channel input signal 1400 having at least two channels and, preferably, having at least three channels l, c, r.

[0122] The encoder includes an energy measure calculator 1402 for calculating an error measure depending on an energy difference between an energy of the multi-channel input signal 1400 or an at least one base channel 1404 and an up-mixed signal 1406 generated by a non-energy conserving up-mixing operation 1407.

[0123] Furthermore, the encoder includes an output interface 1408 for outputting the at least one base channel after being scaled (401, 402) by a scaling factor 403 depending on the energy measure or for outputting the energy measure itself.

[0124] In a preferred embodiment, the encoder includes a down-mixer 1410 for generating the at least one base channel 1404 from the original multi-channels 1400. For generating the up-mix parameters, a difference calculator 1414 and a parameter optimiser 1416 are also present. These elements are operative to find the best-matching up-mix parameters 1412. At least two of this set of best fitting up-mix parameters are outputted via the output interface as the parameter output in a preferred embodiment. The difference calculator is preferably operative to perform a minimum means square error calculation between the original multi-channel signal 1400 and the up-mixer-generated up-mix signal for parameters input at parameter line 1412. This parameter optimisation procedure can be performed by several different optimisation procedures, which are all driven by the goal to obtain a best-matching up-mix result 1406 by a certain up-mixing matrix included in the up-mixer 1407.

[0125] The functionality of Fig. 14a encoder is shown in Fig. 14b. After a down-mixing step 1440 performed by the down-mixer 1410, the base channel or the plurality of base channels can be output as illustrated by 1442. Then, an up-mix parameter optimisation step 1444 is performed, which, depending on a certain optimisation strategy, can be an iterative or non-iterative procedure. However, iterative procedures are preferred. Generally, the up-mix parameter optimisation procedure can be implemented such that the difference between the up-mix result and the original signal is as low as possible. Depending on the implementation, this difference can be an individual channel-related difference or a combined difference. Generally, the up-mix parameter optimisation step 1444 is operative in minimising any cost function, which can be derived from individual channels or from combined channels so that, for one channel, a larger difference (error) is accepted, when a much better matching is, for example, achieved for the other two channels.

[0126] Then, when the best fitting parameters set, e.g., the best fitting up-mix matrix has been found, at least two up-mixing parameters of the parameters set generated by step 1444 are output to the output interface as indicated by step 1446.

[0127] Furthermore, after the up-mix parameter optimisation step 1444 is complete, the energy measure can be calculated and output as indicated by step 1448. Generally, the energy measure will depend on the energy error 1210. In a preferred embodiment, the energy measure is the factor ρ which depends on the relation of the energy of the up-mix result 1406 and the energy of the original signal 1400 as shown in Fig. 2. Alternatively, the energy measure calculated and output can be an absolute value for the energy error 1210 or can be the absolute energy of the up-mix result 1406, which, of course, depends on the energy error. In this context, it is to be noted that the energy measure as output by the output interface 1408 is preferably quantized, and, again preferably entropy-encoded using any well-known entropy-

encoder such as an arithmetic encoder, a Huffman encoder or a run-length encoder, which is especially useful when there are many subsequent identical energy measures. Alternatively or additionally, the energy measures for subsequent time portions or frames can be difference-encoded, wherein this difference-encoding is preferably performed before entropy-coding.

5 **[0128]** Subsequently, reference is made to Fig. 15a showing an alternative down-mixer embodiment, which is, in accordance with a preferred embodiment of the present invention, combined to the Fig. 14a encoder. The Fig. 15a embodiment covers an SBR-implementation, although this embodiment can also be used in cases, in which no spectral band replication is performed, but in which the complete bandwidth of the base channels is transmitted. The Fig. 15a encoder includes a down-mixer 1500 for down-mixing the original signal 1500 to obtain at least one base channel 1504. In a non-SBR-embodiment, the at least one base channel 1504 is input into a core coder 1506, which can be an AAC encoder for mono-signals in case of a single base channel, or which can be any stereo coder in case of for example two stereo base channels. On the output of the core coder 1506, a bit stream including an encoded base channel or including a plurality of encoded base channels is output (1508).

10 **[0129]** When the Fig. 15a embodiment has an SBR functionality, the at least one base channel 1504 is low-pass filtered 1510 before being input into the core coder. Naturally, the functionalities of blocks 1510 and 1506 can be implemented by a single encoder device, which performs low-pass filtering and core coding within a single encoding algorithm.

15 **[0130]** The encoded base channels at the output 1508 only include a low-band of the base channels 1504 in encoded form. Information on the high-band is calculated by an SBR spectral envelope calculator 1512, which is connected to an SBR information encoder 1514 for generating and outputting encoded SBR-side information at an output 1516.

20 **[0131]** The original signal 1502 is input into an energy calculator 1520, which generates channel energies (for a certain time period of the original channels l, c, r, wherein the channel energies are indicated by L, C, R, output by block 1520). The channel energies L, C, R, are input into a parameter calculator block 1522. The parameter calculator 1522 outputs two up-mix parameters c_1 , c_2 , which can, for example, be the parameters c_1 , c_2 , indicated in Fig. 15a. Naturally, other (e.g. linear) energy combinations involving the energies of all input channels can be generated by the parameter calculator 1522 for transmission to a decoder. Naturally, different transmitted up-mix parameters will result in a different way of calculating the remaining up-mixing matrix elements. As indicated in connection with equation (40) or equations (41 - 44), the up-mix matrix for the energy-directed Fig. 15 embodiment has at least four non-zero elements, wherein the elements in the third row are equal to each other. Thus, the parameter calculator 1522 can use any combination of energies L, C, R for example, from which the four elements in the up-mix matrix such as up-mix matrix indication (40) or (41) can be derived.

25 **[0132]** The Fig. 15a embodiment illustrates an encoder, which is operative to perform the energy-preserving, or, stated in general, the energy-derived up-mix for the whole bandwidth of a signal. This means that, on the encoder-side, which is illustrated in Fig. 15a, the parametric representation output by the parameter calculator 1522 is generated for the whole signal. This means that, for each sub-band of the encoded base channel, a corresponding set of parameters is calculated and output. When, for example, the encoded base channel, which is, for example, a full-bandwidth signal having ten sub-bands is considered, the parameter calculator might output ten parameters c_1 and c_2 for each sub-band of the encoded base channel. When, however, the encoded base channel would be a low-band signal in an SBR environment, for example only covering only the five lower sub-bands, then the parameter calculator 1522 would output a set of parameters for each of the five lower sub-bands, and, additionally, for each of the five upper sub-bands, although the signal at output 1508 does not include a corresponding sub-band. This is due to the fact, that such a sub-band would be recreated on the decoder-side, as will be subsequently described in connection with Fig. 16a.

30 **[0133]** Preferably, however, and as described in connection with Fig. 10, the energy calculator 1520 and the parameter calculator 1522 are only operative for the high-band part of the original signal, while parameters for the low-band part of the original signal are calculated by the predictive parameter calculator 104 in Fig. 10, which would correspond to the predictive up-mixer 109 in Fig. 10.

35 **[0134]** Fig. 15b shows a schematic representation of a parametric representation output by selection module 1002 in Fig. 10. Thus, a parametric representation in accordance with the present invention includes (with or without the encoded base channel(s) and, optionally, even without the energy measure) a set of predictive parameters for the low-band, e.g., for the sub-bands 1 to i and sub-band-wise parameters for the high-band, e.g., for the sub-bands i+1 to N. Alternatively, the predictive parameters and the energy style parameters can be mixed, e.g., that a sub-band having energy style parameters can be positioned between sub-bands having predictive parameters.

40 **[0135]** Furthermore, a frame having only predictive parameters can follow a frame having only energy style parameters. Therefore, generally stated, the present invention as discussed in connection with Fig. 10 relates to different parameterisations, which can be different in the frequency direction as shown in Fig. 15b or which can be different in the time direction, when a frame having only predictive parameters is followed by a frame having only energy style parameters. Naturally, the distribution or parameterisation of sub-bands can change from frame to frame, so that, for example, sub-band i has a first (e.g. predictive) parameter set as shown in Fig. 15b at first frame, and has a second (e.g. energy style)

parameter set in another frame.

[0136] Furthermore, the present invention is also useful when parameterisations different from the predictive parameterisation as shown in Fig. 14a or the energy style parameterisation as shown in Fig. 15a are used. Also further examples for parameterisation apart from predictive or energy style can be used as soon as any target parameter or target event indicates that the up-mix quality, the down-mix bit rate, the computational efficiency on the encoder side or on the decoder side or, for example, the energy consumption of e.g. battery-powered devices, etc. say that, for a certain sub-band or frame, the first parameterisation is better than the second parameterisation. Naturally, the target function can also be a combination of different individual targets/events as outlined above. An exemplary event would be a SBR-reconstructed high band etc.

[0137] Furthermore, it is to be noted that the frequency or time-selective calculation and transmission of parameters can be signalled explicitly as shown at 1005 in Fig. 10. Alternatively, the signalling can also be performed implicitly such as discussed in connection with Fig. 16a. In this case, pre-defined rules for the decoder are used, for example that the decoder automatically assumes that the transmitted parameters are energy style parameters for sub-bands belonging to the high-band in Fig. 15b, e.g., for sub-bands, which have been reconstructed by a spectral band replication or highfrequency regeneration technique.

[0138] Furthermore, it is to be noted that the inventive encoder-side calculation of one, two or even more different parameterisations and the encoder-side selection, which parameterisation is transmitted is based on a decision using any encoder-side available information (the information can be an actually used target function or signalling information used for other reasons such as SBR processing and signalling) can be performed with or without transmitting the energy measure. Even when the preferred energy correction is not performed at all, e.g., when the result of the non-energy-conserving up-mix (predictive up-mix) is not energy-corrected, or when no corresponding pre-compensation on the encoder-side is performed, the inventive switching between different parameterisations is useful for obtaining a better multi-channel output quality and/or lower bit rate.

[0139] Particularly, the inventive switching between different parameterisations depending on available encoder-side information can be used with or without addition of a de-correlated signal completely or at least partly covering the energy error performed by the predictive up-mix as shown in connection with Figs. 5 to 7. In this context, the addition of a de-correlated signal as described in connection with Fig. 5 is only performed for the sub-bands/frames, for which predictive up-mix parameters are transmitted, while different measures for de-correlation are used for those sub-bands or frames, in which energy style parameters have been transmitted. Such measures are, for example, down-scaling the wet signal and generating a de-correlated signal and scaling the de-correlated signal so that a required amount of de-correlation as, for example, required by a transmitted inter-channel-correlation measure such as ICC is obtained, when the properly scaled de-correlated signals are added to the dry signal.

[0140] Subsequently, Fig. 16a is discussed for illustrating a decoder-side implementation of the inventive up-mixing block 201 and the corresponding energy correction in 202. As discussed in connection with Fig. 11, transmitted up-mix parameter 1108 are extracted from a received input signal. These transmitted up-mix parameters are preferably input into a calculator 1600 for calculating the remaining up-mix parameters, when the up-mix matrix 1602 including energy compensation is to perform a predictive up-mix and a preceding or subsequent energy correction. The procedure for calculating the remaining up-mix parameters is subsequently discussed in connection with Figs. 16b.

[0141] The calculation of the up-mix parameters is based on the equation in Fig. 16b, which is also repeated as equation (7). In the three-input-signal/two-output-signal embodiment, the down-mix matrix D has six variables. Additionally, the up-mix matrix C has also six variables. However, on the right hand side of equation (7), there are only four values. Therefore, in case of an unknown down-mix and unknown up-mix, one would have twelve unknown variables from matrices D and C and only four equations for determining these twelve variables. However, the down-mix is known so that the number of variables, which are unknown reduces to the coefficients of the up-mix matrix C, which has six variables, although there still exist four equations for determining these six variables. Therefore, the optimisation method as discussed in connection with step 1444 in Fig. 14b and as illustrated in Fig. 14a is used for determining at least two variables of the up-mix matrix, which are, preferably, c_{11} and c_{22} . Now, since there exist four unknowns, e.g., c_{12} , c_{21} , c_{31} and c_{32} and since there exist four equations, e.g., one equation for each element in the identity matrix I on the right hand side of the equation in Fig. 16b, the remaining unknown variables of the up-mix matrix can be calculated in a straight-forward manner. This calculation is performed in the calculator 1600 for calculating the remaining up-mix parameters.

[0142] The up-mix matrix in the device 1602 is set in accordance with the two transmitted up-mix parameters as forwarded by broken line 1604 and by the remaining four up-mix parameters calculated by block 1600. This up-mix matrix is then applied to the base channels input via line 1102. Depending on the implementation, an energy measure for a low-band correction is forwarded via line 1106 so that a corrected up-mix can be generated and output. When the predictive up-mix is only performed for the low-band as, for example, implicitly signalled via line 1606, and when there exist energy style up-mix parameters on line 1108 for the high-band, this fact is signalled, for a corresponding sub-band, to the calculator 1600 and to the up-mix matrix device 1602. In the energy style case, it is preferred to calculate the up-

mix matrix elements of up-mix matrix (40) or (41). To this end, the transmitted parameters as indicated below equation (40) or the corresponding parameters as indicated below equation (41) are used. In this embodiment, the transmitted up-mix parameters c_1 , c_2 cannot be directly used for an up-mix coefficient, but the up-mix coefficients of the up-mix matrix as shown in equation (40) or (41) have to be calculated using the transmitted up-mix parameters c_1 and c_2 .

5 **[0143]** For the high-band, an up-mix matrix as determined for the energy-based up-mix parameters is used for up-mixing the high-band part of the multi-channel output signals. Subsequently, the low-band part and the high-band part are combined in a low/high combiner 1608 for outputting the full-bandwidth reconstructed output channels 1, r, c. As illustrated in Fig. 16a, the high-band of the base channels is generated using a decoder for decoding the transmitted low-band base channels, wherein this decoder is a mono-decoder for a mono base channel, and is a stereo decoder for two stereo base channels. This decoded low-band base channel(s) are input into an SBR device 1614, which additionally receives envelope information as calculated by device 1512 in Fig. 15a. Based on the low-band part and the high band envelope information, the high band of the base channels is generated to obtain full band-width base channels on the line 1102, which are forwarded into the up-mix matrix device 1602.

10 **[0144]** The inventive methods or devices or computer programs can be implemented or included in several devices. Fig. 17 shows a transmission system having a transmitter including an inventive encoder and having a receiver including an inventive decoder. The transmission channel can be a wireless or wired channel. Furthermore, as shown in Fig. 18, the encoder can be included in an audio recorder or the decoder can be included in an audio player. Audio records from the audio recorder can be distributed to the audio player via the Internet or via a storage medium distributed using mail or courier resources or other possibilities for distributing storage media such as memory cards, CDs or DVDs.

15 **[0145]** Depending on certain implementation requirements of the inventive methods, the inventive methods can be implemented in hardware or in software. The implementation can be performed using a digital storage medium, in particular a disk or a CD having electronically readable control signals stored thereon, which can cooperate with a programmable computer system such that the inventive methods are performed. In other words, the inventive methods are, therefore, a computer program having a program code for performing the inventive methods, when the computer program runs on a computer.

25 **Claims**

30 **1.** Multi-channel synthesiser for generating at least three audio output channels (1100) using an input signal having at least one base channel (1102), the base channel being derived from the original multi-channel signal (101, 102, 103), the input signal further including at least two different up-mixing parameters (1108), and an up-mixer mode indication (1005) indicating, in a first state that a first up-mixing rule is to be performed, and, indicating, in a second state, that a different second up-mixing rule is to be performed, comprising:

35 an up-mixer (1104) for up-mixing the at least one base channel using the at least two different up-mixing parameters (1108) based on the first or the second up-mixing rule in response to the up-mixer mode indication (1005) so that the at least three output channels are obtained,

40 **characterized in that** the first up-mixing rule is a predictive up-mixing rule (109) and the second up-mixing rule is an up-mixing rule having energy-dependent up-mixing parameters (1003).

45 **2.** Multi-channel synthesiser in accordance with claim 1, in which the up-mixer (1104) is operative when upmixing, to calculate, in dependence on the up-mixer mode indication (1005), parameters for the first or the second up-mixing rule using the at least two different up-mixing parameters (1108) in dependence on the up-mixer mode indication (1005).

50 **3.** Multi-channel synthesiser in accordance with claim 1 or 2, in which the up-mixer mode indication (1005) indicates a frequency selective or sub-band-wise or time selective or frame-wise signalling an up-mixer mode, and in which the upmixer is operative to upmix the at least one base channel using different upmixing rules for different frequency bands or time portions as indicated by the up-mixer mode indication (1005).

55 **4.** Multi-channel synthesiser in accordance with claim 1, in which the second up-mixing rule is defined as follows:

$$C = \begin{pmatrix} \sqrt{\frac{L}{L + \alpha^2 C}} & 0 \\ 0 & \sqrt{\frac{R}{R + \alpha^2 C}} \\ \sqrt{\frac{C}{L + R + 4\alpha^2 C}} & \sqrt{\frac{C}{L + R + 4\alpha^2 C}} \end{pmatrix},$$

wherein L is an energy value of a left input channel,
 wherein C is an energy value of a centre input channel,
 wherein R is an energy value of a right input channel, and wherein α is a down-mix determined parameter.

5. Multi-channel synthesiser in accordance with one of claims 1 to 4, in which the second up-mixing rule is so that a right down-mix channel is not added to a left up-mixed channel and vice versa.
6. Multi-channel synthesiser in accordance with one of claims 1 to 5, in which the first up-mixing rule is determined by a wave form matching between wave forms of the original multi-channel signal and wave forms of signals generated by the first up-mixing rule.
7. Multi-channel synthesiser in accordance with one of claims 1 to 6, in which one of the first or second up-mixing rules is determined as follows:

$$C = \begin{pmatrix} f_1(c_1, c_2) f_2(c_1, c_2) \\ f_2(c_2, c_1) f_1(c_2, c_1) \\ f_3(c_1, c_2) f_3(c_1, c_2) \end{pmatrix},$$

in which function f_1 , f_2 , f_3 indicate functions of the transmitted two different up-mixing parameters c_1 , c_2 , and, in which the functions are determined as follows:

$$f_1(c_1, c_2) = \sqrt{1 - c_1^2}$$

$$f_2(c_1, c_2) = 0$$

$$f_3(c_1, c_2) = \frac{c_1}{2\alpha},$$

wherein α is a real-valued parameter.

8. Multi-channel synthesiser in accordance with one of claims 1 to 7, further comprising an SBR unit (1614) for regenerating a band of the at least one base channel not included in the transmitted base channel using a part of the at least one base channel included in the input signal, and wherein the multi-channel synthesiser is operative to apply the second up-mixing rule in a regenerated band of the

at least base-channel, and to apply the first up-mixing rule in a band of the base channel, which is included in the input signal.

- 5 9. Multi-channel synthesiser in accordance with claim 8, in which the up-mixer mode indication (1005) is an SBR signalling (1606) included in the input signal.
- 10 10. Multi-channel synthesiser in accordance with one of the preceding claims, in which the input signal includes an energy measure (1106) indicating information on an energy error depending on an energy-loss introducing up-mixing rule, and
 10 in which the upmixer is operative to use the energy-loss introducing upmixing rule as one of the first or second upmixing rule and to generate the at least three output channels such that the energy error is at least partly compensated for based on the energy measure.
- 15 11. Multi-channel synthesiser in accordance with one of the preceding claims, in which the upmixer is operative to extract the energy measure (1106) from the input signal and to use the energy measure as the up-mixer mode indication (1005) so that the upmixer is operative to apply the energy-loss introducing upmixing rule in response to a presence of the energy measure (1106) in the input signal.
- 20 12. Multi-channel synthesiser in accordance with claim 11, in which the energy measure indicates an indication of a relation of an energy of an up-mix result using the energy-loss introducing up-mixing rule to an energy of the original multi-channel signal, or an indication of a relation of the energy difference to an energy or the original multi-channel signal or an indication of the energy error in absolute terms.
- 25 13. Multi-channel synthesiser in accordance with one of the preceding claims, in which the up-mixer includes a calculator (1600) for deriving, in response to the up-mixer mode indication (1005), an up-mix matrix based on the at least two up-mixing parameters and information on a down-mix rule used for generating the at least one base channel from the original multi-channel signal.
- 30 14. Multi-channel synthesiser in accordance with one of claims 10 to 13, in which the up-mixer (1104) further comprises a de-correlator (501, 502, 503, 501', 503') for generating a de-correlated signal from the at least one base channel or from the output signals of the energy-loss introducing up-mixing rule, and
 35 in which the up-mixer is operative to use the de-correlated signal such that an energy amount of the de-correlated signal in an output channel is smaller than or equal to an amount of the energy error as derivable by the energy measure.
- 40 15. Multi-channel synthesiser in accordance with claim 14, in which, when the energy of the decorrelated signal is smaller than the energy error, the upmixer is operative to upscale a signal generated by the upmixing rule such that the combined energy of the upscaled signal and the added decorrelated signal is equal to an energy of the original signal.
- 45 16. Multi-channel synthesiser in accordance with claim 14 or 15, in which the energy of the added de-correlated signal is determined by a de-correlation factor, wherein a high de-correlation factor close to 1 indicates that a smaller level de-correlated signal is to be added, while a smaller de-correlation factor close to 0 indicates that a higher level de-correlation signal is to be added, and
 wherein the de-correlation measure is extracted from the input signal.
- 50 17. Multi-channel synthesiser in accordance with one of the preceding claims, in which the input signal includes, in addition to the two different up-mixing parameters information on a down-mix underlying the at least one base channel,
 in which the up-mixer is operative to use the additional down-mixing information for generating an up-mixing matrix (802).
- 55 18. Encoder for processing a multi-channel audio input signal, comprising:
 a parameter generator (104, 1001, 1520, 1522, 1414, 1416) for generating a specific parametric representation among a plurality of different parametric representations based on information available at the encoder, the parametric representation being useful when upmixing one or more base channels for reconstructing a multi-channel output signal; and

an output interface (1408) for outputting the generated parametric representation and information implicitly or explicitly indicating the specific parametric representation among the plurality of different parametric representations,

5 **characterized in that** the plurality of different parametric representations includes a first parametric representation for a wave form-based predictive up-mixing scheme (104), and a second parametric representation for a non-wave form-based up-mixing rule having energy-dependent up-mixing parameters (1001).

10 **19.** Encoder in accordance with claim 18, in which the non-wave form-based up-mixing rule is an energy-conserving up-mixing rule.

20. Encoder in accordance with one of claims 18 to 19, in which a first parametric representation is a parametric representation, the parameters of which are determined using an optimisation procedure, and in which a second parametric representation is determined by calculating (1520) the energies of the original channels and by calculating parameters (1522) based on combinations of energies.

15 **21.** Encoder in accordance with one of claims 18 to 20, further comprising a spectral band replication module (1512, 1514) for generating spectral band replication side information for at least one band of the original input signal, which is not included in a base channel output by the encoder, the spectral band replication side information implicitly indicating a specific parametric representation.

20 **22.** Encoder in accordance with one of claims 18 to 21, further comprising:
 an energy measure calculator (1402) for calculating an energy measure (ρ) depending on an energy difference between a multi-channel input signal or an at least one base channel derived from the multi-channel input signal and an up-mixed signal generated by an energy-loss introducing up-mixing operation; and in which the output interface (1408) is operative to output the at least one base channel after being scaled (401, 402) by a scaling factor (403) dependent on the energy measure or to output the energy measure.

25 **23.** Encoder in accordance with claim 22, in which the energy measure (ρ) output by the output interface is used for implicitly signalling a specific parametric representation.

24. Encoder in accordance with one of claims 18 to 23, further comprising a parametric representation controller for controlling the parameter generator or the output interface which parametric representation among the plurality of different parametric representations is to be generated or output.

30 **25.** Encoder in accordance with one of claims 18 to 24, in which the parametric representation controller is operative to determine an event in the encoder or to calculate a target function.

26. Encoder in accordance with claim 25, in which the event in the encoder is a calculation of spectral band replication information so that the controller is operative to control the output interface to output a second parametric representation for a band not included in a base channel, and to output a first parametric representation for a band included in the base channel.

35 **27.** Encoder in accordance with one of claims 18 to 25, in which the parametric representation controller is operative to use, in the target function a value or a combination of values derived from an up-mix quality, a down-mix bit rate, a computational efficiency on the encoder side or on a decoder side or an energy consumption of a battery-powered devices, the target function indicating that, for a certain sub-band or frame, the first parameterisation is better than the second parameterisation.

40 **28.** Encoder in accordance with any one of claims, in which the output interface is operative to output different parametric representations for different frequency bands or time periods.

45 **29.** Encoder in accordance with any one of claims 18 to 28, further comprising an energy measure calculator for calculating an energy measure based on a relation of an energy of the up-mixed signal generated by up-mixing the at least one base channel using an energy-loss-introducing up-mixing rule, and an energy of the original multi-channel signal.

30. Encoder in accordance with one of claims 18 to 29, which further comprises a down-mixer device (1410) for calculating at least one base channel, and in which the output interface (1408) is operative to output the at least one base channel.
- 5 31. Method of generating at least three audio output channels (1100) using an input signal having at least one base channel (1102), the base channel being derived from the original multi-channel signal (101, 102, 103), the input signal further including at least two different up-mixing parameters (1108), and an up-mixer mode indication (1005) indicating, in a first state that a first up-mixing rule is to be performed, and, indicating, in a second state, that a different second up-mixing rule is to be performed, comprising:
- 10 up-mixing (1104) the at least one base channel using the at least two different up-mixing parameters (1108) based on the first or the second up-mixing rule in response to the up-mixer mode indication (1005) so that the at least three output channels are obtained,
- 15 **characterized in that** the first up-mixing rule is a predictive up-mixing rule (109) and the second up-mixing rule is an up-mixing rule having energy-dependent up-mixing parameters (1003).
32. Method of processing a multi-channel audio input signal, comprising :
- 20 generating (104, 1001, 1520, 1522, 1414, 1416) a specific parametric representation among a plurality of different parametric representations based on information available at the encoder, the parametric representation being useful when upmixing one or more base channels for reconstructing a multi-channel output signal; and
- 25 outputting (1408) the generated parametric representation and information implicitly or explicitly indicating the specific parametric representation among the plurality of different parametric representations,
- characterized in that** the plurality of different parametric representations includes a first parametric representation for a wave form-based predictive up-mixing scheme (104), and a second parametric representation for a non-wave form-based up-mixing rule having energy-dependent up-mixing parameters (1001).
- 30 33. Encoded multi-channel audio information signal having a specific parametric representation among a plurality of different parametric representations, the parametric representation being useful when upmixing one or more base channels for reconstructing a multi-channel output signal, and information implicitly or explicitly indicating the specific parametric representation among the plurality of different parametric representations, **characterized in that** the plurality of different parametric representations includes a first parametric representation for a wave form-based predictive up-mixing scheme (104), and a second parametric representation for a non-wave form-based up-mixing rule having energy-dependent up-mixing parameters (1001).
- 35 34. Machine-readable medium having stored thereon an encoded multi-channel information signal in accordance with claim 33.
- 40 35. Transmitter or audio recorder having an encoder in accordance with any one of claims 18 to 30.
36. Receiver or audio player having a synthesiser in accordance with any one of claims 1 to 17.
- 45 37. Transmission system having a transmitter in accordance with claim 35 and a receiver in accordance with claim 36.
38. Method of transmitting or audio recording, the method having a method of processing in accordance with claim 32.
- 50 39. Method of receiving or audio playing, the method including a method of generating in accordance with claim 31.
40. Method of receiving in accordance with claim 39 and transmitting in accordance with claim 38.
- 55 41. Computer program comprising computer program code means which perform, when running on a computer, all the steps of a method in accordance with any one of the methods of claims 31, 32, 38, 39 or 40.

Patentansprüche

1. Mehrkanalsynthetisierer zum Erzeugen von zumindest drei Audioausgangskanälen (1100) unter Verwendung eines Eingangssignals, das zumindest einen Basiskanal (1102) aufweist, wobei der Basiskanal von dem ursprünglichen Mehrkanalsignal (101, 102, 103) abgeleitet ist, wobei das Eingangssignal ferner zumindest zwei unterschiedliche Heraufumsetzparameter (1108) und eine Heraufumsetzermodusangabe (1105) umfasst, die in einem ersten Zustand angibt, dass eine erste Heraufumsetzregel durchgeführt werden soll, und in einem zweiten Zustand angibt, dass eine unterschiedliche, zweite Heraufumsetzregel durchgeführt werden soll, der folgende Merkmale aufweist:

einen Heraufumsetzer (1104) zum Heraufumsetzen des zumindest einen Basiskanals unter Verwendung der zumindest zwei unterschiedlichen Heraufumsetzparameter (1108) basierend auf der ersten oder der zweiten Heraufumsetzregel ansprechend auf die Heraufumsetzermodusangabe (1005), so dass die zumindest drei Ausgangskanäle erhalten werden,

dadurch gekennzeichnet, dass die erste Heraufumsetzregel eine prädiktive Heraufumsetzregel (109) ist und die zweite Heraufumsetzregel eine Heraufumsetzregel ist, die energieabhängige Heraufumsetzparameter (1003) aufweist.

2. Mehrkanalsynthetisierer gemäß Anspruch 1, bei dem der Heraufumsetzer (1104) bei dem Heraufumsetzen wirksam ist, um in Abhängigkeit von der Heraufumsetzermodusangabe (1005) Parameter für die erste oder die zweite Heraufumsetzregel unter Verwendung der zumindest zwei unterschiedlichen Heraufumsetzparameter (1008) in Abhängigkeit von der Heraufumsetzermodusangabe (1005) zu berechnen.

3. Mehrkanalsynthetisierer gemäß Anspruch 1 oder 2, bei dem die Heraufumsetzermodusangabe (1005) eine frequenzselektive oder subbandweise oder zeitselektive oder rahmenweise Signalisierung eines Heraufumsetzermodus angibt, und wobei der Heraufumsetzer wirksam ist, um den zumindest einen Basiskanal unter Verwendung unterschiedlicher Heraufumsetzregeln für unterschiedliche Frequenzbänder oder Zeitabschnitte herauf umzusetzen, wie es durch die Heraufumsetzermodusangabe (1005) angegeben ist.

4. Mehrkanalsynthetisierer gemäß Anspruch 1, bei dem die zweite Heraufumsetzregel wie folgt definiert ist:

$$C = \begin{pmatrix} \sqrt{\frac{L}{L + \alpha^2 C}} & 0 \\ 0 & \sqrt{\frac{R}{R + \alpha^2 C}} \\ \sqrt{\frac{C}{L + R + 4\alpha^2 C}} & \sqrt{\frac{C}{L + R + 4\alpha^2 C}} \end{pmatrix},$$

wobei L ein Energiewert eines Links-Eingangskanals ist, wobei C ein Energiewert eines Mitten-Eingangskanals ist, wobei R ein Energiewert eines Rechts-Eingangskanals ist und wobei α ein bestimmter Herunterumsetzparameter ist.

5. Mehrkanalsynthetisierer gemäß einem der Ansprüche 1 bis 4, bei dem die zweite Heraufumsetzregel so ist, dass ein Rechts-Herunterumsetzkanal nicht zu einem Links-Heraufumsetzkanal hinzugefügt wird, und umgekehrt.

6. Mehrkanalsynthetisierer gemäß einem der Ansprüche 1 bis 5, bei dem die erste Heraufumsetzregel durch eine Wellenformanpassung zwischen Wellenformen des ursprünglichen Mehrkanalsignals und Wellenformen von Signalen, die durch die erste Heraufumsetzregel erzeugt sind, bestimmt ist.

7. Mehrkanalsynthetisierer gemäß einem der Ansprüche 1 bis 6, bei dem eine der ersten oder der zweiten Heraufumsetzregel wie folgt bestimmt ist:

$$C = \begin{pmatrix} f_1(c_1, c_2) f_2(c_1, c_2) \\ f_2(c_2, c_1) f_1(c_2, c_1) \\ f_3(c_1, c_2) f_3(c_1, c_2) \end{pmatrix},$$

wobei Funktionen f_1 , f_2 , f_3 Funktionen der übertragenen zwei unterschiedlichen Heraufumsetzparameter c_1 , c_2 angeben, und wobei die Funktionen wie folgt bestimmt sind:

$$f_1(c_1, c_2) = \sqrt{1 - c_1^2}$$

$$f_2(c_1, c_2) = 0$$

$$f_3(c_1, c_2) = \frac{c_1}{2\alpha},$$

wobei α ein reellwertiger Parameter ist.

8. Mehrkanalsynthetisierer gemäß einem der Ansprüche 1 bis 7, der ferner eine SBR-Einheit (1614) zum Regenerieren eines Bands des zumindest einen Basiskanals, der nicht in dem übertragenen Basiskanal eingeschlossen ist, unter Verwendung eines Teils des zumindest einen Basiskanals, der in dem Eingangssignal eingeschlossen ist, aufweist, und wobei der Mehrkanalsynthetisierer wirksam ist, um die zweite Heraufumsetzregel bei einem regenerierten Band des zumindest eines Basiskanals anzuwenden und die erste Heraufumsetzregel bei einem Band des Basiskanals anzuwenden, das in dem Eingangssignal eingeschlossen ist.
9. Mehrkanalsynthetisierer gemäß Anspruch 8, bei dem die Heraufumsetzermodusangabe (1005) eine SBR-Signalisierung (1606) ist, die in dem Eingangssignal eingeschlossen ist.
10. Mehrkanalsynthetisierer gemäß einem der vorhergehenden Ansprüche, bei dem das Eingangssignal ein Energiemaß (1106) umfasst, das Informationen über einen Energiefehler angibt, der von einer einen Energieverlust einbringenden Heraufumsetzregel abhängt, und wobei der Heraufumsetzer wirksam ist, um die einen Energieverlust einbringende Heraufumsetzregel als eine der ersten oder der zweiten Heraufumsetzregel zu verwenden und die zumindest drei Ausgangskanäle zu erzeugen, derart, dass der Energiefehler basierend auf dem Energiemaß zumindest teilweise kompensiert wird.
11. Mehrkanalsynthetisierer gemäß einem der vorhergehenden Ansprüche, bei dem der Heraufumsetzer wirksam ist, um das Energiemaß (1106) aus dem Eingangssignal zu extrahieren und das Energiemaß als die Heraufumsetzermodusangabe (1005) zu verwenden, so dass der Heraufumsetzer wirksam ist, um die einen Energieverlust einbringende Heraufumsetzregel ansprechend auf ein Vorhandensein des Energiemaßes (1106) in dem Eingangssignal anzuwenden.
12. Mehrkanalsynthetisierer gemäß Anspruch 11, bei dem das Energiemaß eine Angabe einer Beziehung einer Energie eines Heraufumsetzergenerierungsergebnisses unter Verwendung der einen Energieverlust einbringenden Heraufumsetzregel zu einer Energie des ursprünglichen Mehrkanalsignals oder eine Angabe einer Beziehung der Energiedifferenz zu einer Energie oder dem ursprünglichen Mehrkanalsignal oder eine Angabe des Energiefehlers in absoluten Ausdrücken angibt.
13. Mehrkanalsynthetisierer gemäß einem der vorhergehenden Ansprüche, bei dem der Heraufumsetzer eine Berech-

nungseinrichtung (1600) zum Ableiten einer Heraufumsetzmatrix ansprechend auf die Heraufumsetzermodusangabe (1005) basierend auf den zumindest zwei Heraufumsetzparametern und Informationen über eine Herabumsetzregel aufweist, die zum Erzeugen des zumindest einen Basiskanals aus dem ursprünglichen Mehrkanalsignal verwendet wird.

- 5
14. Mehrkanalsynthetisierer gemäß einem der Ansprüche 10 bis 13, bei dem der Heraufumsetzer (1104) ferner einen Dekorrelator (501, 502, 503, 501', 503') zum Erzeugen eines dekorrelierten Signals aus dem zumindest einen Basiskanal oder aus den Ausgangssignalen der einen Energieverlust einbringenden Heraufumsetzregel aufweist, und
- 10 wobei der Heraufumsetzer wirksam ist, um das dekorrelierte Signal zu verwenden, derart, dass eine Energiegröße des dekorrelierten Signals in einem Ausgangskanal kleiner oder gleich einer Größe des Energiefehlers ist, der durch das Energiemaß ableitbar ist.
- 15 15. Mehrkanalsynthetisierer gemäß Anspruch 14, bei dem, wenn die Energie des dekorrelierten Signals kleiner als der Energiefehler ist, der Heraufumsetzer wirksam ist, um ein Signal, das durch die Heraufumsetzregel erzeugt ist, aufwärts zu skalieren, derart, dass die kombinierte Energie des aufwärts skalierten Signals und des hinzugefügten dekorrelierten Signals gleich einer Energie des ursprünglichen Signals ist.
- 20 16. Mehrkanalsynthetisierer gemäß Anspruch 14 oder 15, bei dem die Energie des hinzugefügten dekorrelierten Signals durch einen Dekorrelationsfaktor bestimmt ist, wobei ein hoher Dekorrelationsfaktor nahe an 1 angibt, dass ein dekorreliertes Signal mit kleinerem Pegel hinzugefügt werden soll, während ein kleinerer Dekorrelationsfaktor nahe an 0 angibt, dass ein Dekorrelationssignal mit höherem Pegel hinzugefügt werden soll, und wobei das Dekorrelationsmaß aus dem Eingangssignal extrahiert ist.
- 25 17. Mehrkanalsynthetisierer gemäß einem der vorhergehenden Ansprüche, bei dem das Eingangssignal zusätzlich zu den zwei unterschiedlichen Heraufumsetzparametern Informationen über eine Herabumsetzung umfasst, die dem zumindest einen Basiskanal zu Grunde liegt, wobei der Heraufumsetzer wirksam ist, um die zusätzlichen Herabumsetzungsinformationen zum Erzeugen einer Heraufumsetzmatrix (802) zu verwenden.
- 30 18. Codierer zum Verarbeiten eines Mehrkanalaudioeingangssignals, der folgende Merkmale aufweist:
- einen Parametergenerator (104, 1001, 1520, 1522, 1414, 1416) zum Erzeugen einer spezifischen parametrischen Darstellung unter einer Mehrzahl unterschiedlicher parametrischer Darstellungen basierend auf Informationen, die bei dem Codierer verfügbar sind, wobei die parametrische Darstellung bei einem Heraufumsetzen eines oder mehrerer Basiskanäle zum Rekonstruieren eines Mehrkanalausgangssignals nützlich ist; und
- 35 eine Ausgabeschnittstelle (1408) zum Ausgeben der erzeugten parametrischen Darstellung und von Informationen, die implizit oder explizit die spezifische parametrische Darstellung unter der Mehrzahl unterschiedlicher parametrischer Darstellungen angeben,
- 40 **dadurch gekennzeichnet, dass** die Mehrzahl unterschiedlicher parametrischer Darstellungen eine erste parametrische Darstellung für ein wellenformbasiertes prädiktives Heraufumsetzschema (104) und eine zweite parametrische Darstellung für eine nicht wellenformbasierte Heraufumsetzregel, die energieabhängige Heraufumsetzparameter (1001) aufweist, umfasst.
- 45 19. Codierer gemäß Anspruch 18, bei dem die nicht wellenformbasierte Heraufumsetzregel eine energiebewahrende Heraufumsetzregel ist.
- 50 20. Codierer gemäß einem der Ansprüche 18 bis 19, bei dem eine erste parametrische Darstellung eine parametrische Darstellung ist, deren Parameter unter Verwendung einer Optimierungsprozedur bestimmt sind, und wobei eine zweite parametrische Darstellung durch ein Berechnen (1520) der Energien der ursprünglichen Kanäle und durch ein Berechnen von Parametern (1522) basierend auf Kombinationen von Energien bestimmt ist.
- 55 21. Codierer gemäß einem der Ansprüche 18 bis 20, der ferner ein Spektralbandreplikationsmodul (1512, 1514) zum Erzeugen von Spektralbandreplikationsseiteninformationen für zumindest ein Band des ursprünglichen Eingangssignals aufweist, das nicht in einem Basiskanal eingeschlossen ist, der durch den Codierer ausgegeben wird, wobei die Spektralbandreplikationsseiteninformationen implizit eine spezifische parametrische Darstellung angeben.

22. Codierer gemäß einem der Ansprüche 18 bis 21, der ferner folgendes Merkmal aufweist:

5 eine Energiemaßberechnungseinrichtung (1402) zum Berechnen eines Energiemaßes (ρ), das von einer Energiedifferenz zwischen einem Mehrkanaleingangssignal oder zumindest einem Basissignal, das von dem Mehrkanaleingangssignal abgeleitet ist, und einem heraufumgesetzten Signal abhängt, das durch eine einen Energieverlust einbringende Heraufumsetzoperation erzeugt ist; und

10 wobei die Ausgabeschnittstelle (1408) wirksam ist, um den zumindest einen Basiskanal nach einem Skalieren (401, 402) durch einen Skalierungsfaktor (403) abhängig von dem Energiemaß auszugeben oder das Energiemaß auszugeben.

23. Codierer gemäß Anspruch 22, bei dem das Energiemaß (ρ), das durch die Ausgabeschnittstelle ausgegeben wird, zum impliziten Signalisieren einer spezifischen parametrischen Darstellung verwendet wird

15 24. Codierer gemäß einem der Ansprüche 18 bis 23, der ferner eine Parameterdarstellungssteuerung zum Steuern des Parametergenerators oder der Ausgabeschnittstelle aufweist, welche parametrische Darstellung unter der Mehrzahl unterschiedlicher parametrischer Darstellungen erzeugt oder ausgegeben werden soll.

20 25. Codierer gemäß einem der Ansprüche 18 bis 24, bei dem die Parameterdarstellungssteuerung wirksam ist, um ein Ereignis in dem Codierer zu bestimmen oder um eine Zielfunktion zu berechnen.

25 26. Codierer gemäß Anspruch 25, bei dem das Ereignis in dem Codierer eine Berechnung von Spektralbandreplikationsinformationen ist, so dass die Steuerung wirksam ist, um die Ausgabeschnittstelle zu steuern, um eine zweite parametrische Darstellung für ein Band auszugeben, das nicht in einem Basiskanal eingeschlossen ist, und eine erste parametrische Darstellung für ein Band auszugeben, das in dem Basiskanal eingeschlossen ist.

30 27. Codierer gemäß einem der Ansprüche 18 bis 25, bei dem die Parameterdarstellungssteuerung wirksam ist, um bei der Zielfunktion einen Wert oder eine Kombination von Werten zu verwenden, die von einer Heraufumsetzqualität, einer Herabumsetzbitrate, einer Recheneffizienz auf der Codiererseite oder auf einer Decoderseite oder einem Energieverbrauch einer batteriebetriebenen Vorrichtung abgeleitet sind, wobei die Zielfunktion angibt, dass für ein bestimmtes Subband oder einen bestimmten Rahmen die erste Parametrisierung besser als die zweite Parametrisierung ist.

35 28. Codierer gemäß irgendeinem der Ansprüche, bei dem die Ausgabeschnittstelle wirksam ist, um unterschiedliche parametrische Darstellungen für unterschiedliche Frequenzbänder oder Zeitperioden auszugeben.

40 29. Codierer gemäß einem der Ansprüche 18 bis 28, der ferner eine Energiemaßberechnungseinrichtung zum Berechnen eines Energiemaßes basierend auf einer Beziehung einer Energie des heraufumgesetzten Signals, das durch ein Heraufumsetzen des zumindest einen Basiskanal unter Verwendung einer einen Energieverlust einbringenden Heraufumsetzregel erzeugt ist, und einer Energie des ursprünglichen Mehrkanalsignals aufweist.

45 30. Codierer gemäß einem der Ansprüche 18 bis 29, der ferner eine Herunterumsetzvorrichtung (1410) zum Berechnen zumindest eines Basiskanal aufweist, und wobei die Ausgabeschnittstelle (1408) wirksam ist, um den zumindest einen Basiskanal auszugeben.

50 31. Verfahren zum Erzeugen von zumindest drei Audioausgangskanälen (1100) unter Verwendung eines Eingangssignals, das zumindest einen Basiskanal (1102) aufweist, wobei der Basiskanal von dem ursprünglichen Mehrkanalsignal (101, 102, 103) abgeleitet ist, wobei das Eingangssignal ferner zumindest zwei unterschiedliche Heraufumsetzparameter (1108) und eine Heraufumsetzmodusangabe (1105) umfasst, die in einem ersten Zustand angibt, dass eine erste Heraufumsetzregel durchgeführt werden soll, und in einem zweiten Zustand angibt, dass eine unterschiedliche, zweite Heraufumsetzregel durchgeführt werden soll, das folgende Schritte aufweist:

55 Heraufumsetzen (1104) des zumindest einen Basiskanal unter Verwendung der zumindest zwei unterschiedlichen Heraufumsetzparameter (1108) basierend auf der ersten oder der zweiten Heraufumsetzregel ansprechend auf die Heraufumsetzmodusangabe (1005), so dass die zumindest drei Ausgangskanäle erhalten werden,

dadurch gekennzeichnet, dass die erste Heraufumsetzregel eine prädiktive Heraufumsetzregel (109) ist und die

zweite Heraufumsetzregel eine Heraufumsetzregel ist, die energieabhängige Heraufumsetzparameter (1003) aufweist.

32. Verfahren zum Verarbeiten eines Mehrkanalaudioeingangssignals, das folgende Schritte aufweist:

Erzeugen (104, 1001, 1520, 1522, 1414, 1416) einer spezifischen parametrischen Darstellung unter einer Mehrzahl unterschiedlicher parametrischer Darstellungen basierend auf Informationen, die bei dem Codierer verfügbar sind, wobei die parametrische Darstellung bei einem Heraufumsetzen eines oder mehrerer Basiskanäle zum Rekonstruieren eines Mehrkanalausgangssignals nützlich ist; und Ausgeben (1408) der erzeugten parametrischen Darstellung und von Informationen, die implizit oder explizit die spezifische parametrische Darstellung unter der Mehrzahl unterschiedlicher parametrischer Darstellungen angeben,

dadurch gekennzeichnet, dass die Mehrzahl unterschiedlicher parametrischer Darstellungen eine erste parametrische Darstellung für ein wellenformbasiertes prädiktives Heraufumsetzschema (104) und eine zweite parametrische Darstellung für eine nicht wellenformbasierte Heraufumsetzregel, die energieabhängige Heraufumsetzparameter (1001) aufweist, umfasst.

33. Codiertes Mehrkanalaudioinformationssignal, das eine spezifische parametrische Darstellung unter einer Mehrzahl unterschiedlicher parametrischer Darstellungen, wobei die parametrische Darstellung bei einem Heraufumsetzen eines oder mehrerer Basiskanäle zum Rekonstruieren eines Mehrkanalausgangssignals nützlich ist, und Informationen aufweist, die implizit oder explizit die spezifische parametrische Darstellung unter der Mehrzahl unterschiedlicher parametrischer Darstellungen angeben, **dadurch gekennzeichnet, dass** die Mehrzahl unterschiedlicher parametrischer Darstellungen eine erste parametrische Darstellung für ein wellenformbasiertes prädiktives Heraufumsetzschema (104) und eine zweite parametrische Darstellung für eine nicht wellenformbasierte Heraufumsetzregel, die energieabhängige Heraufumsetzparameter (1001) aufweist, umfasst.

34. Maschinenlesbares Medium, auf dem ein codiertes Mehrkanalinformationssignal gemäß Anspruch 33 gespeichert ist.

35. Sender oder Audioaufzeichnungsgerät mit einem Codierer gemäß einem der Ansprüche 18 bis 30.

36. Empfänger oder Audioabspielgerät mit einem Synthetisierer gemäß einem der Ansprüche 1 bis 17.

37. Übertragungssystem, das einen Sender gemäß Anspruch 35 und einen Empfänger gemäß Anspruch 36 aufweist.

38. Verfahren zum Senden oder Aufzeichnen von Audio, wobei das Verfahren ein Verfahren zum Verarbeiten gemäß Anspruch 32 aufweist.

39. Verfahren zum Empfangen oder Abspielen von Audio, wobei das Verfahren ein Verfahren zum Erzeugen gemäß Anspruch 31 umfasst.

40. Verfahren zum Empfangen gemäß Anspruch 39 und Senden gemäß Anspruch 38.

41. Computerprogramm, das eine Computerprogrammcodeeinrichtung aufweist, die, wenn dieselbe auf einem Computer läuft, alle Schritte eines Verfahrens gemäß einem der Verfahren der Ansprüche 31, 32, 38, 39 oder 40 durchführt.

Revendications

1. Synthétiseur multicanal pour générer au moins trois canaux de sortie audio (1100) à l'aide d'un signal d'entrée présentant au moins un canal de base (1102), le canal de base étant dérivé du signal multicanal original (101, 102, 103), le signal d'entrée comportant, par ailleurs, au moins deux paramètres de mélange ascendant différents (1108), et une indication de mode de mélangeur ascendant (1005) indiquant, dans un premier état, qu'il y a lieu de réaliser une première règle de mélange ascendant et indiquant, dans un deuxième état, qu'il y a lieu de réaliser une deuxième règle de mélange ascendant différente, comprenant:

un mélangeur ascendant (1104) pour effectuer un mélange ascendant de l'au moins un canal de base à l'aide des au moins deux paramètres de mélange ascendant différents (1108) sur base de la première ou de la deuxième règle de mélange ascendant en réponse à l'indication de mode de mélangeur ascendant (1005) de sorte que soient obtenus les au moins trois canaux de sortie,

5 **caractérisé par le fait que** la première règle de mélange ascendant est une règle de mélange ascendant prédictif (109) et que la deuxième règle de mélange ascendant est une règle de mélange ascendant présentant des paramètres de mélange ascendant fonction de l'énergie (1003).

10 **2.** Synthétiseur multicanal selon la revendication 1, dans lequel le mélangeur ascendant (1104) est opérationnel lors du mélange ascendant, pour calculer, en fonction de l'indication de mode de mélangeur ascendant (1005), les paramètres pour la première ou la deuxième règle de mélange ascendant à l'aide des au moins deux paramètres de mélange ascendant différents (1108) en fonction de l'indication de mode de mélangeur ascendant (1005).

15 **3.** Synthétiseur multicanal selon la revendication 1 ou 2, dans lequel l'indication de mode de mélangeur ascendant (1005) indique une signalisation sélective en fréquence ou par sous-bande ou sélective en temps ou par trame d'un mode de mélangeur ascendant, et dans lequel le mélangeur ascendant est opérationnel pour effectuer un mélange ascendant dudit au moins un canal de base à l'aide de règles de mélange ascendant différentes pour différentes bandes de fréquence ou parties de temps, comme indiqué par l'indication de mode de mélangeur ascendant (1005).

20 **4.** Synthétiseur multicanal selon la revendication 1, dans lequel la deuxième règle de mélange ascendant est définie comme suit:

25

$$C = \begin{pmatrix} \sqrt{\frac{L}{L + \alpha^2 C}} & 0 \\ 0 & \sqrt{\frac{R}{R + \alpha^2 C}} \\ \sqrt{\frac{C}{L + R + 4\alpha^2 C}} & \sqrt{\frac{C}{L + R + 4\alpha^2 C}} \end{pmatrix}$$

30

35 où L est une valeur d'énergie d'un canal d'entrée gauche, où C est une valeur d'énergie d'un canal d'entrée central, où R est une valeur d'énergie d'un canal d'entrée droit, et où α est un paramètre déterminé de mélange descendant.

40 **5.** Synthétiseur multicanal selon l'une des revendications 1 à 4, dans lequel la deuxième règle de mélange ascendant est telle qu'un canal de mélange descendant droit n'est pas ajouté à un canal à mélange ascendant gauche, et vice versa.

45 **6.** Synthétiseur multicanal selon l'une des revendications 1 à 5, dans lequel la première règle de mélange ascendant est déterminée par une correspondance de forme d'onde entre les formes d'onde du signal multicanal original et les formes d'onde des signaux générés par la première règle de mélange ascendant.

7. Synthétiseur multicanal selon l'une des revendications 1 à 6, dans lequel l'une des première ou deuxième règles de mélange ascendant est déterminée comme suit:

50

$$C = \begin{pmatrix} f_1(c_1, c_2) f_2(c_1, c_2) \\ f_1(c_2, c_1) f_1(c_2, c_1) \\ f_3(c_1, c_2) f_2(c_2, c_1) \end{pmatrix}$$

55

où les fonctions f_1, f_2, f_3 indiquent les fonctions des deux paramètres de mélange ascendant différents c_1, c_2 transmis, et

où les fonctions sont déterminées comme suit:

$$f_1(c_1, c_2) = \sqrt{1 - c_1^2}$$

$$f_2(c_1, c_2) = 0$$

$$f_3(c_1, c_2) = \frac{c_1}{2\alpha}$$

où α est un paramètre à valeur réelle.

8. Synthétiseur multicanal selon l'une des revendications 1 à 7, comprenant, par ailleurs, une unité SBR (1614) destinée à régénérer une bande de l'au moins un canal de base non comprise dans le canal de base transmis à l'aide d'une partie de l'au moins un canal de base compris dans le signal d'entrée, et dans lequel le synthétiseur multicanal est opérationnel pour appliquer la deuxième règle de mélange ascendant dans une bande régénérée de l'au moins un canal de base, et pour appliquer la première règle de mélange ascendant dans une bande du canal de base qui est comprise dans le signal d'entrée.
9. Synthétiseur multicanal selon la revendication 8, dans lequel l'indication de mode de mélangeur ascendant (1005) est une signalisation SBR (1606) comprise dans le signal d'entrée.
10. Synthétiseur multicanal selon l'une des revendications précédentes, dans lequel le signal d'entrée comprend une information indiquant une mesure d'énergie (1106) sur une erreur d'énergie fonction d'une règle de mélange ascendant introduisant une perte d'énergie, et dans lequel le mélangeur ascendant est opérationnel pour utiliser la règle de mélange ascendant introduisant une perte d'énergie comme l'une parmi les première ou deuxième règles de mélange ascendant et pour générer les au moins trois canaux de sortie de sorte que l'erreur d'énergie soit au moins partiellement compensée sur base de la mesure d'énergie.
11. Synthétiseur multicanal selon l'une des revendications précédentes, dans lequel le mélangeur ascendant est opérationnel pour extraire la mesure d'énergie (1106) du signal d'entrée et pour utiliser la mesure d'énergie comme indication de mode de mélangeur ascendant (1005) de sorte que le mélangeur ascendant soit opérationnel pour appliquer la règle de mélange ascendant introduisant une perte d'énergie en réponse à la présence de la mesure d'énergie (1106) dans le signal d'entrée.
12. Synthétiseur multicanal selon la revendication 11, dans lequel la mesure d'énergie indique une indication d'un rapport entre une énergie d'un résultat de mélange ascendant à l'aide de la règle de mélange ascendant introduisant une perte d'énergie et une énergie du signal multicanal original, ou une indication d'un rapport entre la différence d'énergie et une énergie du signal multicanal original ou une indication de l'erreur d'énergie en valeurs absolues.
13. Synthétiseur multicanal selon l'une des revendications précédentes, dans lequel le mélangeur ascendant comporte un calculateur (1600) destiné à dériver, en réponse à l'indication du mode de mélangeur ascendant (1005), une matrice de mélange ascendant sur base des au moins deux paramètres de mélange ascendant et des informations sur une règle de mélange descendant utilisée pour générer l'au moins un canal de base à partir du signal multicanal original.
14. Synthétiseur multicanal selon l'une des revendications 10 à 13, dans lequel le mélangeur ascendant (1104) comprend, par ailleurs, un décorrélateur (501, 502, 503, 501', 503') destiné à générer un signal décorrélé à partir de l'au moins un canal de base ou à partir des signaux de sortie de la règle de mélange ascendant introduisant une perte d'énergie, et dans lequel le mélangeur ascendant est opérationnel pour utiliser le signal décorrélé de sorte qu'une quantité d'énergie du signal décorrélé dans un canal de sortie soit inférieure ou égale à une quantité de l'erreur d'énergie

pouvant être dérivée par la mesure d'énergie.

- 5 15. Synthétiseur multicanal selon la revendication 14, dans lequel, lorsque l'énergie du signal décorrélé est inférieure à l'erreur d'énergie, le mélangeur ascendant est opérationnel pour effectuer une modulation ascendante d'un signal généré par la règle de mélange ascendant de sorte ascendante et le signal décorrélé ajouté soit égale à l'énergie du signal original.
- 10 16. Synthétiseur multicanal selon la revendication 14 ou 15, dans lequel l'énergie du signal décorrélé ajouté est déterminée par un facteur de décorrélation, dans lequel un haut facteur de décorrélation près de 1 indique qu'il y a lieu d'ajouter un signal décorrélé de niveau inférieur, tandis qu'un facteur de décorrélation inférieur près de 0 indique qu'il y a lieu d'ajouter un signal décorrélé de niveau supérieur, et dans lequel la mesure de décorrélation est extraite du signal d'entrée.
- 15 17. Synthétiseur multicanal selon l'une des revendications précédentes, dans lequel le signal d'entrée comprend, en plus des deux paramètres de mélange ascendant différents, des informations sur un mélange descendant à la base de l'au moins un canal de base, dans lequel le mélangeur ascendant est opérationnel pour utiliser les informations de mélange descendant additionnelles pour générer une matrice de mélange ascendant (802).
- 20 18. Codeur pour traiter un signal d'entrée audio multicanal, comprenant:
- un générateur de paramètres (104, 1001, 1520, 1522, 1414, 1416) pour générer une représentation paramétrique spécifique parmi une pluralité de représentations paramétriques différentes sur base des informations disponibles au niveau du codeur, la représentation paramétrique étant utile lors du mélange ascendant d'un ou de plusieurs canaux de base pour reconstruire un signal de sortie multicanal; et
- 25 une interface de sortie (1408) pour sortir la représentation paramétrique générée et les informations indiquant implicitement ou explicitement la représentation paramétrique spécifique parmi la pluralité de représentations paramétriques différentes,
- 30 **caractérisé par le fait que** la pluralité de représentations paramétriques différentes comprend une première représentation paramétrique pour un schéma de mélange ascendant prédictif sur base de la forme d'onde (104), et une deuxième représentation paramétrique pour une règle de mélange ascendant non sur base de la forme d'onde présentant des paramètres de mélange ascendant fonction de l'énergie (1001).
- 35 19. Codeur selon la revendication 18, dans lequel la règle de mélange ascendant non sur base de la forme d'onde est une règle de mélange ascendant conservant l'énergie.
- 40 20. Codeur selon l'une des revendications 18 à 19, dans lequel une première représentation paramétrique est une représentation paramétrique dont les paramètres sont déterminés à l'aide d'une procédure d'optimisation, et dans lequel une deuxième représentation paramétrique est déterminée en calculant (1520) les énergies des canaux originaux et en calculant les paramètres (1522) sur base de combinaisons d'énergies.
- 45 21. Codeur selon l'une des revendications 18 à 20, comprenant, par ailleurs, un module de reproduction de bande spectrale (1512, 1514) destiné à générer des informations latérales de reproduction de bande spectrale pour au moins une bande du signal d'entrée original qui n'est pas comprise dans un canal de base sorti par le codeur, les informations latérales de reproduction de bande spectrale indiquant implicitement une représentation paramétrique spécifique.
- 50 22. Codeur selon l'une des revendications 18 à 21, comprenant par ailleurs:
- un calculateur de mesure d'énergie (1402) destiné à calculer une mesure d'énergie (ρ) en fonction d'une différence d'énergie entre un signal d'entrée multicanal ou au moins un canal de base dérivé du signal d'entrée multicanal et un signal soumis à un mélange ascendant généré par une opération de mélange ascendant introduisant une perte d'énergie; et
- 55 dans lequel l'interface de sortie (1408) est fonctionnelle pour sortir l'au moins un canal de base après avoir été modulé (401, 402) par un facteur de modulation (403) en fonction de la mesure d'énergie ou pour sortir la mesure d'énergie.

23. Codeur selon la revendication 22, dans lequel la mesure d'énergie (ρ) sortie par l'interface de sortie est utilisée pour signaler implicitement une représentation paramétrique spécifique.

24. Codeur selon l'une des revendications 18 à 23, comprenant, par ailleurs, un contrôleur de représentation paramétrique destiné à contrôler le générateur de paramètres ou l'interface de sortie dont la représentation paramétrique parmi la pluralité de représentations paramétriques différentes doit être générée ou sortie.

25. Codeur selon l'une des revendications 18 à 24, dans lequel le contrôleur de représentation paramétrique est opérationnel pour déterminer un événement dans le codeur ou pour calculer une fonction cible.

26. Codeur selon la revendication 25, dans lequel l'événement dans le codeur est un calcul des informations de reproduction de bande spectrale de sorte que le contrôleur soit opérationnel pour commander l'interface de sortie pour sortir une deuxième représentation paramétrique pour une bande non comprise dans un canal de base, et pour sortir une première représentation paramétrique pour une bande comprise dans le canal de base.

27. Codeur selon l'une des revendications 18 à 25, dans lequel le contrôleur de représentation paramétrique est opérationnel pour utiliser, dans la fonction cible, une valeur ou une combinaison de valeurs dérivée de la qualité de mélange ascendant, d'un débit binaire de mélange descendant, d'une efficacité de calcul du côté du codeur ou du côté du décodeur ou d'une consommation d'énergie de dispositifs alimentés par batteries, la fonction cible indiquant que, pour une certaine sous-bande ou trame, la première paramétrisation est meilleure que la deuxième paramétrisation.

28. Codeur selon l'une quelconque des revendications, dans lequel l'interface de sortie est opérationnelle pour sortir des représentations paramétriques différentes pour des bandes de fréquence ou des périodes de temps différentes.

29. Codeur selon l'une quelconque des revendications 18 à 28, comprenant, par ailleurs, un calculateur de mesure d'énergie destiné à calculer une mesure d'énergie sur base d'un rapport entre une énergie du signal soumis à un mélange ascendant généré par mélange ascendant de l'au moins un canal de base à l'aide d'une règle de mélange ascendant introduisant une perte d'énergie, et l'énergie du signal multicanal original.

30. Codeur selon l'une des revendications 18 à 29, comprenant, par ailleurs, un dispositif mélangeur descendant (1410) destiné à calculer au moins un canal de base, et dans lequel l'interface de sortie (1408) est opérationnelle pour sortir l'au moins un canal de base.

31. Procédé pour générer au moins trois canaux de sortie audio (1100) à l'aide d'un signal d'entrée présentant au moins un canal de base (1102), le canal de base étant dérivé du signal multicanal original (101, 102, 103), le signal d'entrée comprenant, par ailleurs, au moins deux paramètres de mélange ascendant différents (1108), et une indication de mode de mélangeur ascendant (1005) indiquant, dans un premier état, qu'il y a lieu de réaliser une première règle de mélange ascendant et indiquant, dans un deuxième état, qu'il y a lieu de réaliser une deuxième règle de mélange ascendant différente, comprenant:

effectuer un mélange ascendant (1104) sur l'au moins un canal de base à l'aide des au moins deux paramètres de mélange ascendant différents (1108) sur base de la première ou de la deuxième règle de mélange ascendant en réponse à l'indication de mode de mélangeur ascendant (1005) de sorte que soient obtenus les au moins trois canaux de sortie,

caractérisé par le fait que la première règle de mélange ascendant est une règle de mélange ascendant prédictive (109) et la deuxième règle de mélange ascendant est une règle de mélange ascendant présentant des paramètres de mélange ascendant fonction de l'énergie.

32. Procédé de traitement d'un signal d'entrée audio multicanal, comprenant:

générer (104, 1001, 1520, 1522, 1414, 1416) une représentation paramétrique spécifique parmi une pluralité de représentations paramétriques différentes sur base des informations disponibles au niveau du codeur, la représentation paramétrique étant utile lors du mélange ascendant d'un ou de plusieurs canaux de base pour reconstruire un signal de sortie multicanal; et sortir (1408) la représentation paramétrique générée et les informations indiquant implicitement ou explicitement la représentation paramétrique spécifique parmi la pluralité de représentations paramétriques différentes,

caractérisé par le fait que la pluralité de représentations paramétriques différentes comprend une première représentation paramétrique pour un schéma de mélange ascendant prédictif sur base de la forme d'onde (104), et une deuxième représentation paramétrique pour une règle de mélange ascendant non sur base de la forme d'onde présentant des paramètres de mélange ascendant fonction de l'énergie (1001).

- 5
- 10
- 15
- 20
- 25
- 30
- 35
- 40
- 45
- 50
- 55
- 33. Signal d'information audio multicanal codé présentant une représentation paramétrique spécifique parmi une pluralité de représentations paramétriques différentes, la représentation paramétrique étant utile lors du mélange ascendant d'un ou de plusieurs canaux de base pour reconstruire un signal de sortie multicanal, et des informations indiquant implicitement ou explicitement la représentation paramétrique spécifique parmi la pluralité de représentations paramétriques différentes, **caractérisé par le fait que** la pluralité de représentations paramétriques différentes comprend une première représentation paramétrique pour un schéma de mélange ascendant prédictif sur base de la forme d'onde (104), et une deuxième représentation paramétrique pour une règle de mélange ascendant non sur base de la forme d'onde présentant des paramètres de mélange ascendant dépendant de l'énergie (1001).
 - 34. Support lisible en machine présentant, mémorisé sur ce dernier, un signal d'information multicanal codé selon la revendication 33.
 - 35. Emetteur ou enregistreur audio présentant un codeur selon l'une quelconque des revendications 18 à 30.
 - 36. Récepteur ou lecteur audio présentant un synthétiseur selon l'une quelconque des revendications 1 à 17.
 - 37. Système d'émission présentant un émetteur selon la revendication 35 et un récepteur selon la revendication 36.
 - 38. Procédé d'émission ou d'enregistrement audio, le procédé présentant un procédé de traitement selon la revendication 32.
 - 39. Procédé de réception ou de lecture audio, le procédé comprenant un procédé de génération selon la revendication 31.
 - 40. Procédé de réception selon la revendication 39 et d'émission selon la revendication 38.
 - 41. Programme d'ordinateur comprenant des moyens de code de programme effectuant, lorsqu'il est exécuté sur un ordinateur, toutes les étapes d'un procédé selon l'un quelconque des procédés des revendications 31, 32, 38, 39 ou 40.

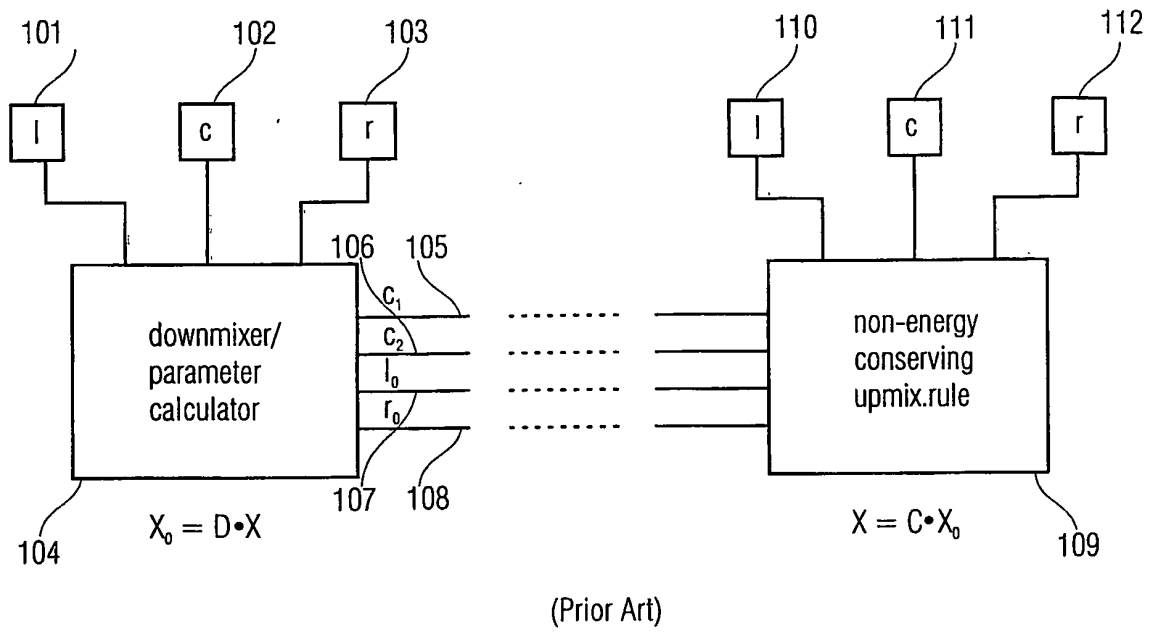

Fig. 1

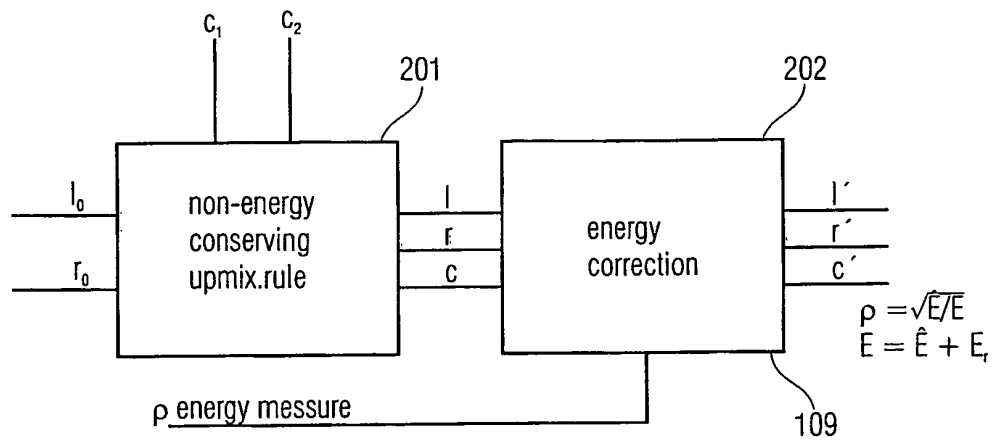

Fig. 2

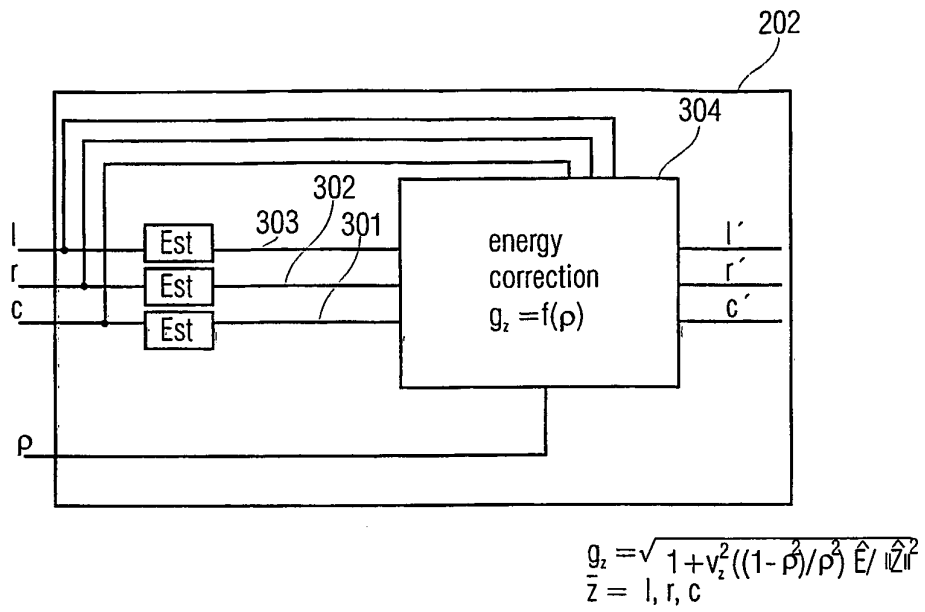

Fig. 3

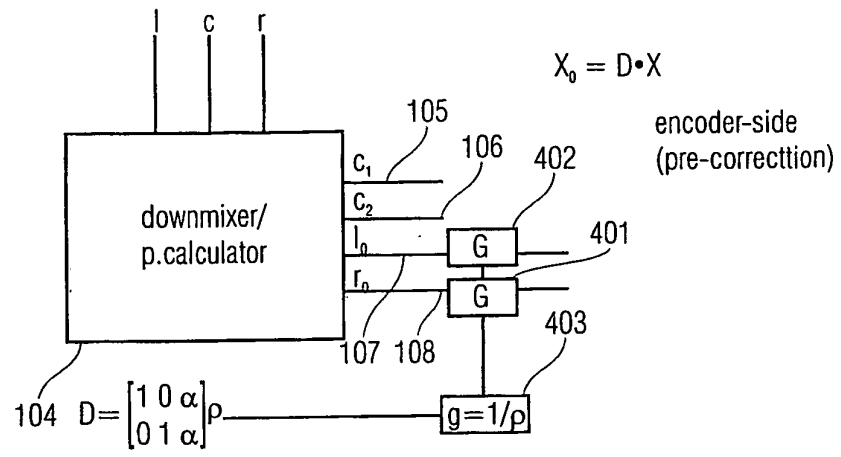

Fig. 4

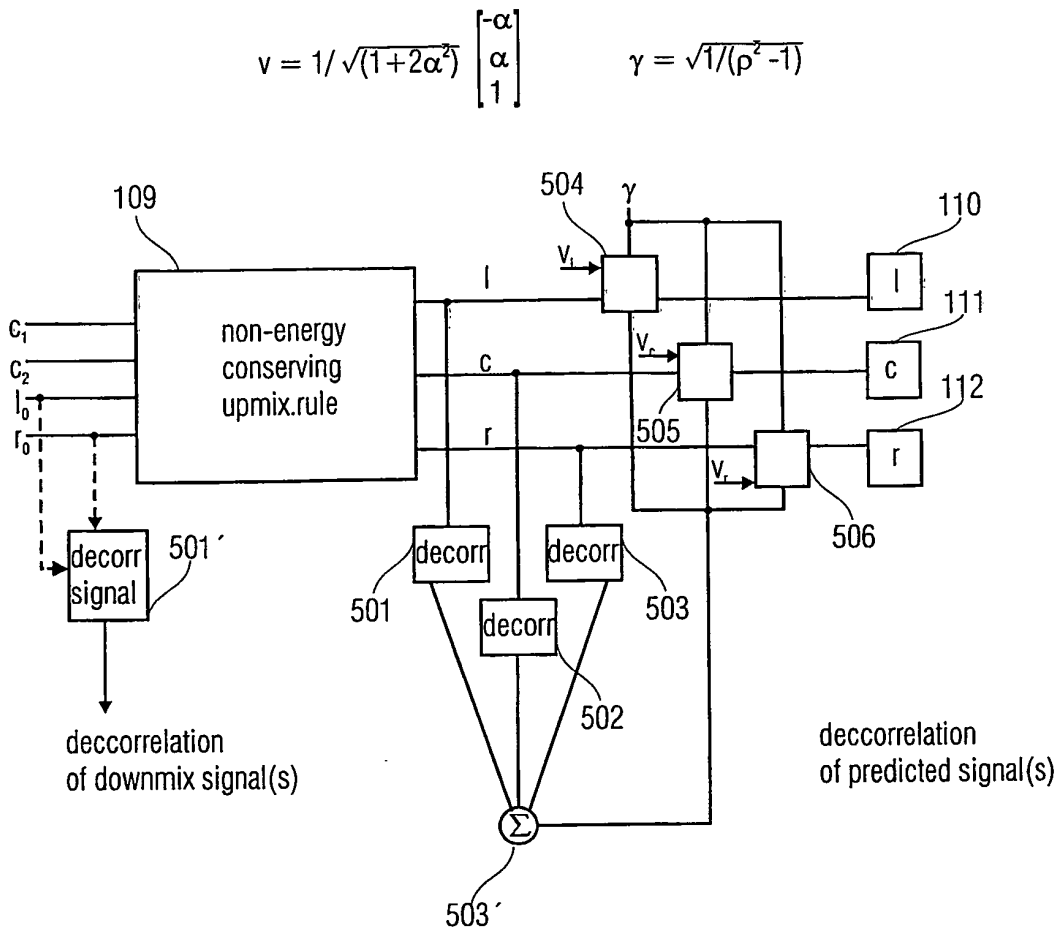

Fig. 5

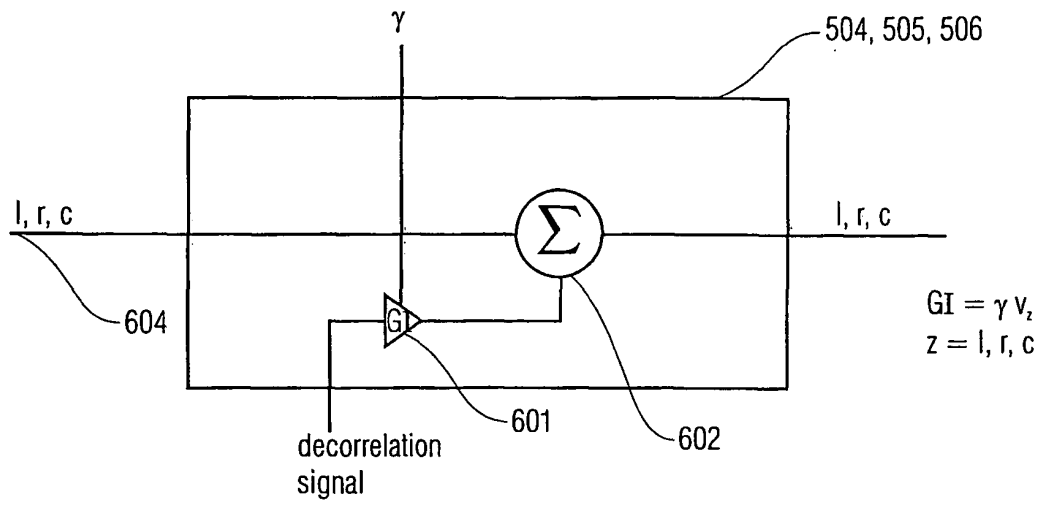

Fig. 6

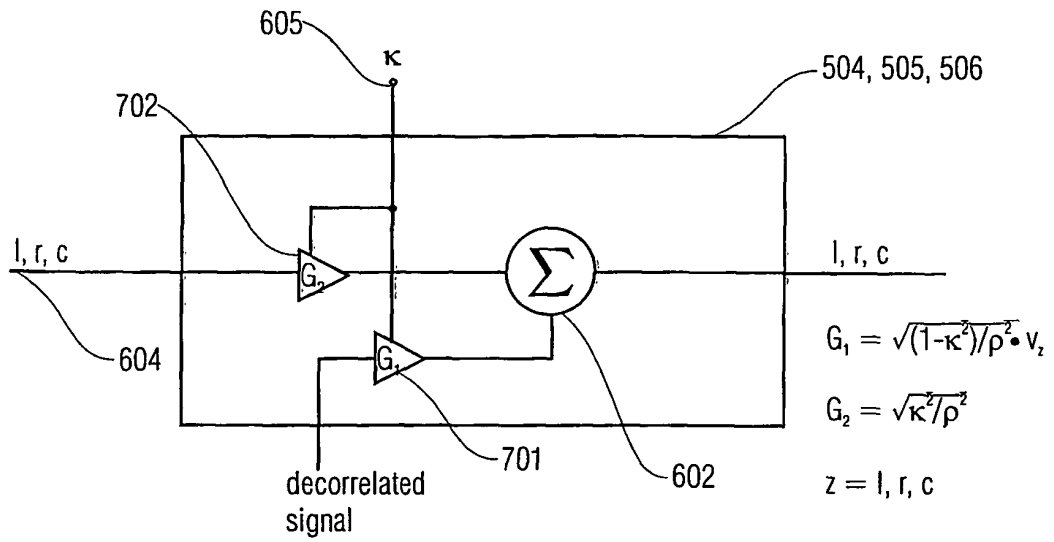

Fig. 7

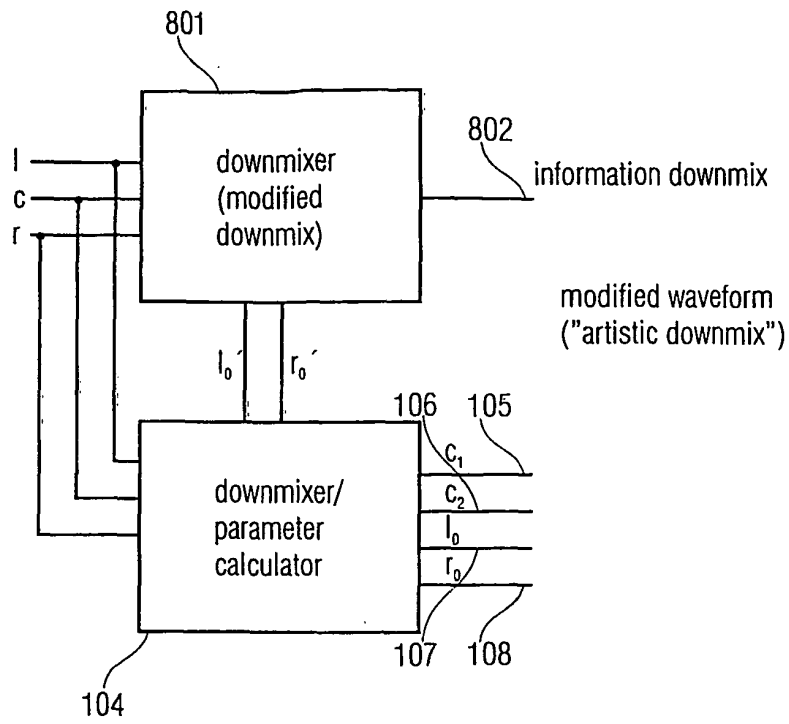

Fig. 8

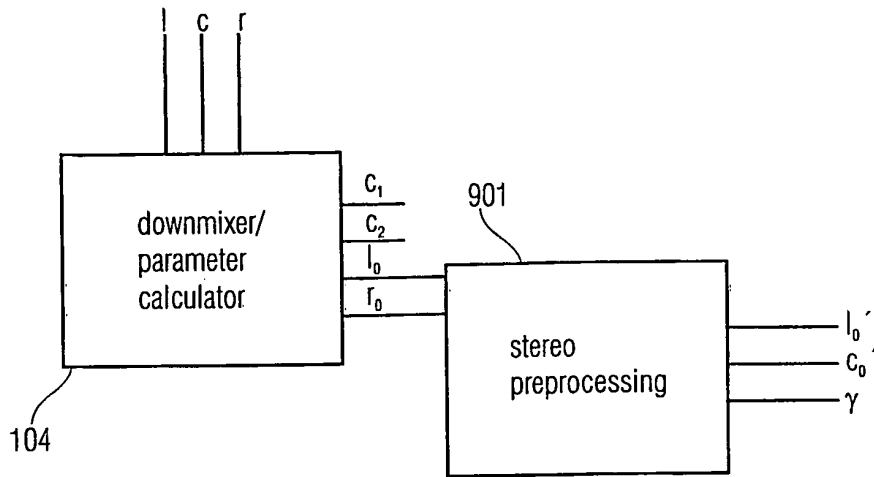

Fig. 9

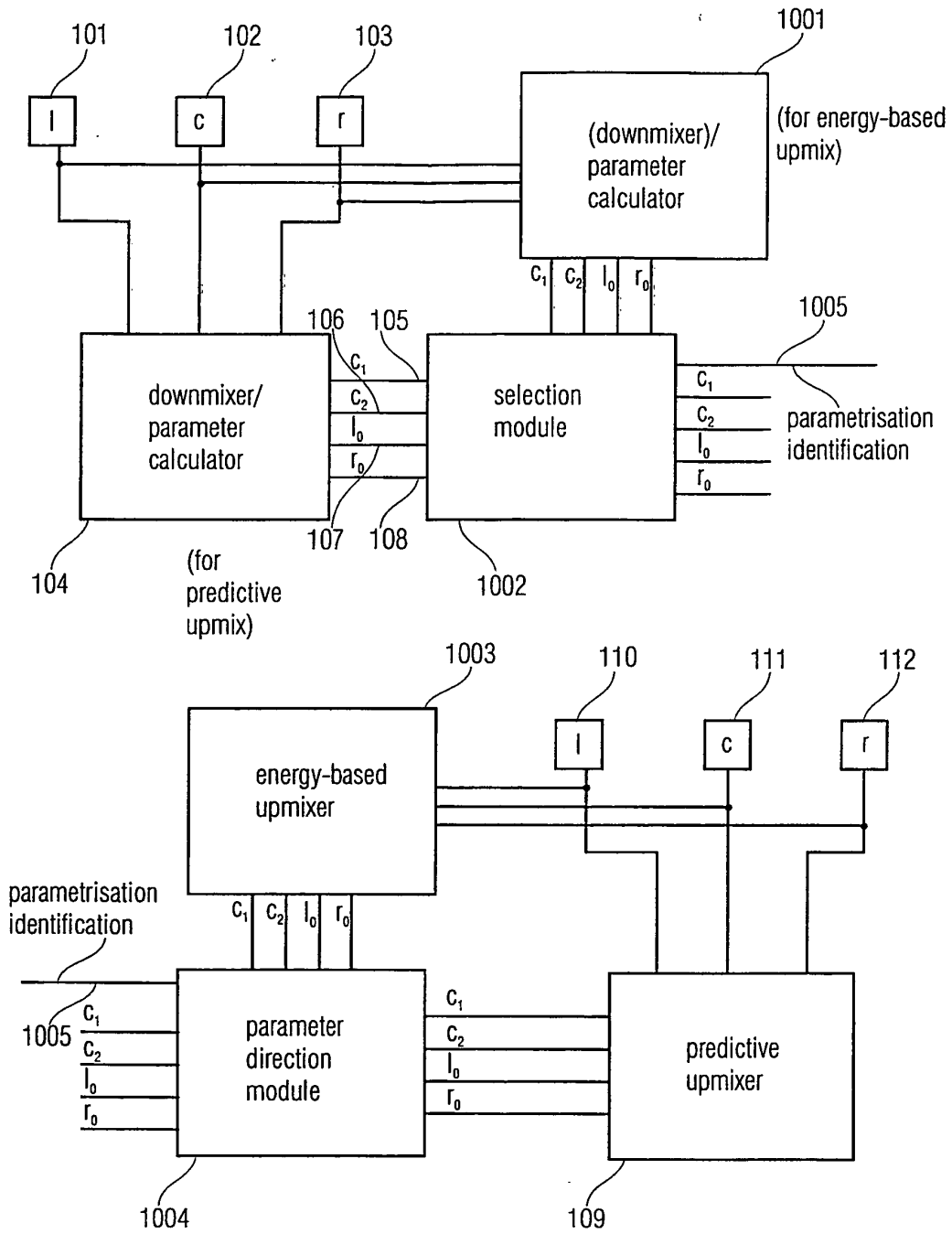

Fig. 10

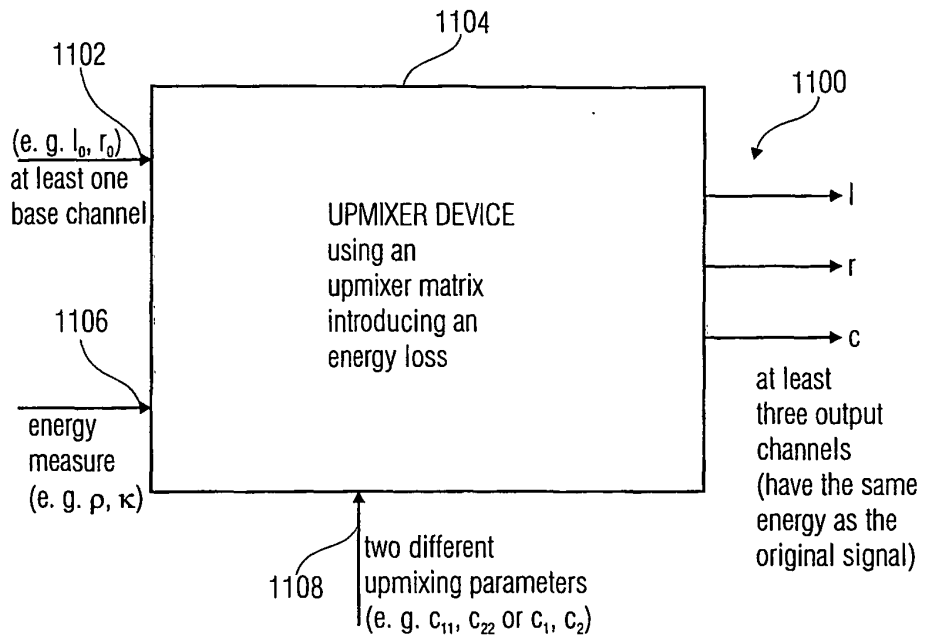

Fig. 11

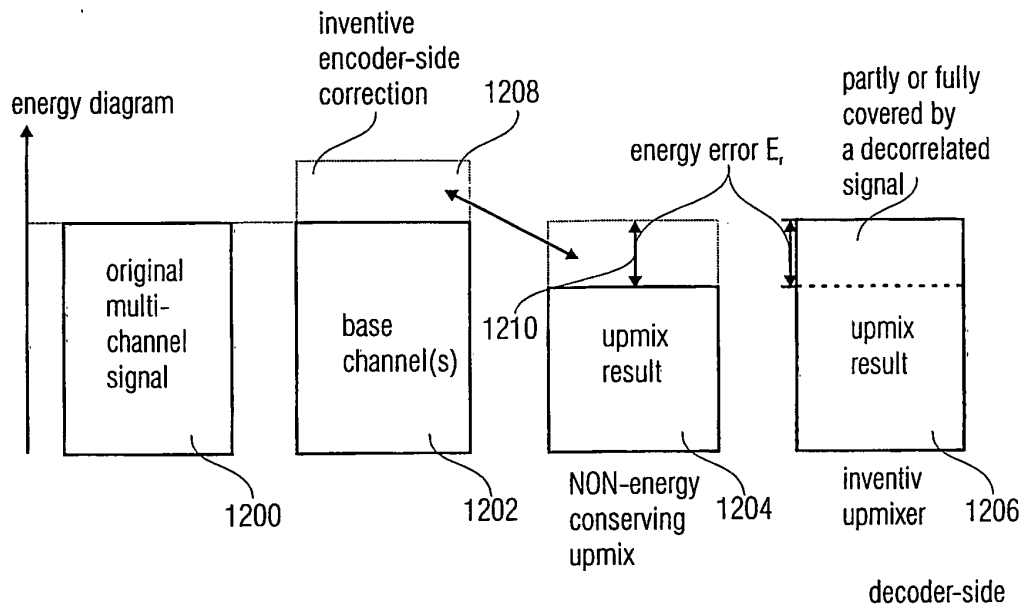

Fig. 12

No.	energy compensation method
1	decoder-side/ subsequent to upmix (Fig. 2)
2	encoder-side/ subsequent to downmix (Fig. 4)
3	decoder-side/ before upmix
4	encoder-side/ before downmix
5	no scaling, but addition of controlled amount of decorr. Signal (Fig. 5)
6	partly scaling, energy remainder is filled up with decorr. Signal (Fig. 7)
8	decorr. Signal is derived from base channel(s) (-> Nos. 5, 6)

Fig. 13

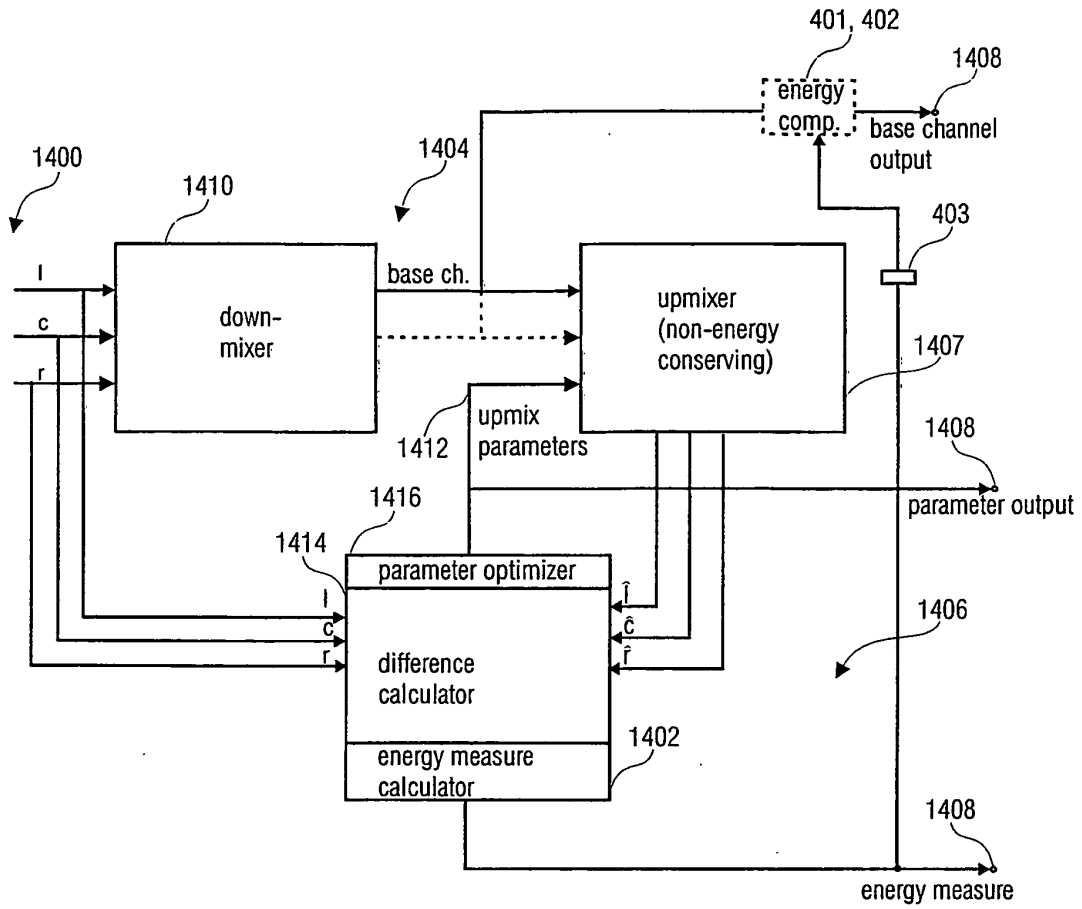

Fig. 14a

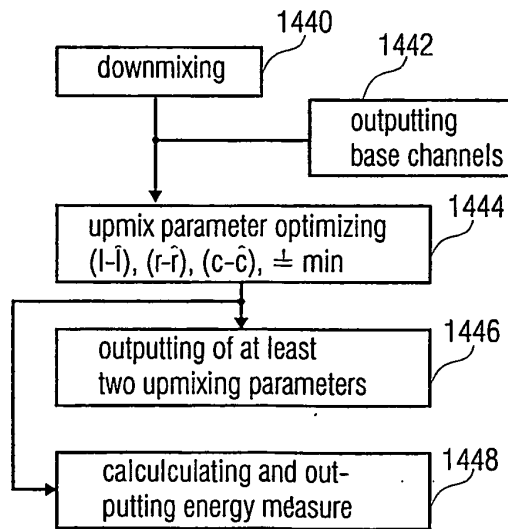

Fig. 14b

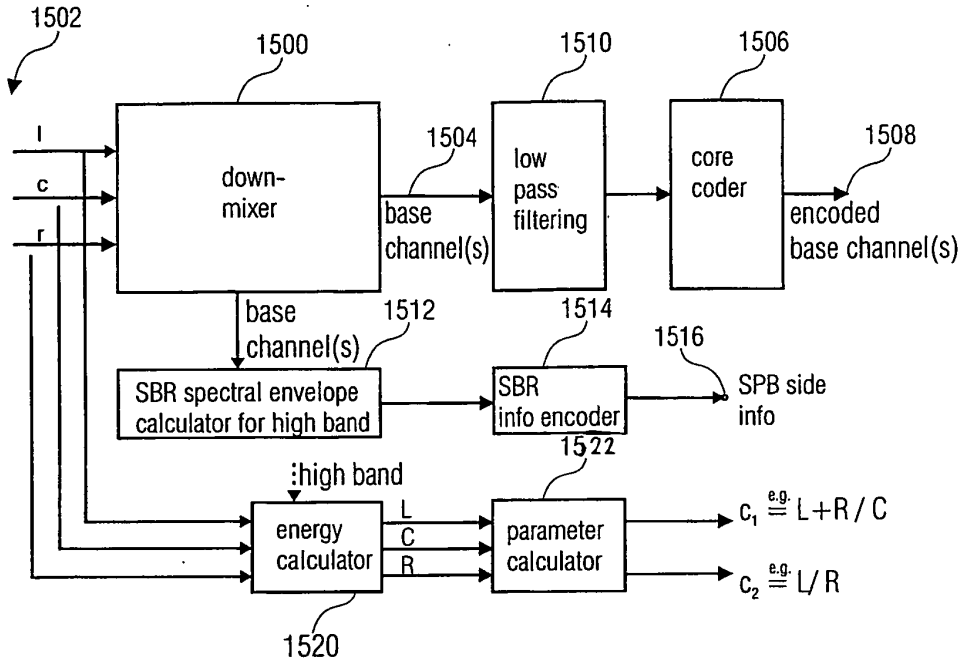

Fig. 15a

1005

ID	SUBBAND	parameters
P	1	predictive Fig14a
P	2	predictive Fig14a
.	.	.
.	.	.
.	.	.
P	i	predictive Fig14a
E	i+1	energy style Fig. 15a
.	.	.
.	.	.
.	.	.
E	N	energy style Fig. 15a

low Band

high band

Fig. 15b

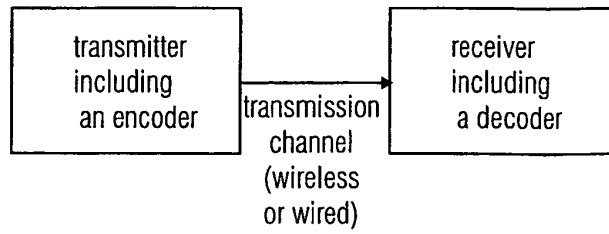

Fig. 17

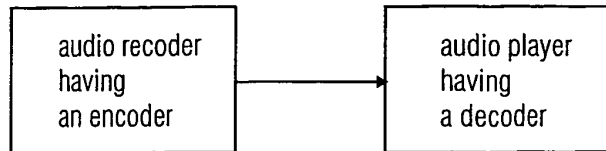

Fig. 18

REFERENCES CITED IN THE DESCRIPTION

This list of references cited by the applicant is for the reader's convenience only. It does not form part of the European patent document. Even though great care has been taken in compiling the references, errors or omissions cannot be excluded and the EPO disclaims all liability in this regard.

Patent documents cited in the description

- WO 9857436 A [0007] [0074]

Non-patent literature cited in the description

- **TEN KATE W R TH.** Compatibility matrixing of multichannel bit-rate-reduced audio signals. *Journal of the Audio Engineering Society*, December 1996, vol. 44 (12), 1104-1119 [0010]