

(19)



(11)

EP 1 735 774 B1

(12)

EUROPEAN PATENT SPECIFICATION

(45) Date of publication and mention of the grant of the patent:
14.05.2008 Bulletin 2008/20

(21) Application number: **05718568.8**

(22) Date of filing: **25.03.2005**

(51) Int Cl.:
G10L 19/00 (2006.01)

(86) International application number:
PCT/IB2005/051037

(87) International publication number:
WO 2005/098821 (20.10.2005 Gazette 2005/42)

(54) **MULTI-CHANNEL ENCODER**

MEHRKANAL-CODIERER

CODEUR A CANUX MULTIPLES

(84) Designated Contracting States:
**AT BE BG CH CY CZ DE DK EE ES FI FR GB GR
HU IE IS IT LI LT LU MC NL PL PT RO SE SI SK TR**

(30) Priority: **05.04.2004 EP 04101405
22.06.2004 EP 04102863**

(43) Date of publication of application:
27.12.2006 Bulletin 2006/52

(73) Proprietor: **Koninklijke Philips Electronics N.V.
5621 BA Eindhoven (NL)**

(72) Inventors:

- **BREEBAART, Dirk, J.
NL-5656 AA Eindhoven (NL)**
- **SCHUIJERS, Erik, G., P.
NL-5656 AA Eindhoven (NL)**
- **HOTH, Gerard, H.
NL-5656 AA Eindhoven (NL)**
- **VAN LOON, Machiel, W.
NL-5656 AA Eindhoven (NL)**

(74) Representative: **van der Veer, Jhannis Leendert
et al
Philips
Intellectual Property & Standards
P.O. Box 220
5600 AE Eindhoven (NL)**

(56) References cited:
WO-A-20/05069274

- **FALLER C ET AL: "BINAURAL CUE CODING: A NOVEL AND EFFICIENT REPRESENTATION OF SPATIAL AUDIO" AUDIO ENGINEERING SOCIETY CONVENTION PAPER, NEW YORK, NY, US, 10 May 2002 (2002-05-10), pages 1841-1844, XP001153972**
- **HERRE J ET AL: "MP3 surround: Efficient and compatible coding of multi-channel audio" AES 116TH CONVENTION, AUDIO ENGINEERING SOCIETY, 8 May 2004 (2004-05-08), pages 1-14, XP002340080 Berlin, Germany**

EP 1 735 774 B1

Note: Within nine months from the publication of the mention of the grant of the European patent, any person may give notice to the European Patent Office of opposition to the European patent granted. Notice of opposition shall be filed in a written reasoned statement. It shall not be deemed to have been filed until the opposition fee has been paid. (Art. 99(1) European Patent Convention).

Description

FIELD OF THE INVENTION

5 **[0001]** The present invention relates to multi-channel encoders, for example multi-channel audio encoders utilizing parametric descriptions of spatial audio. Moreover, the invention also relates to methods of processing signals, for example spatial audio signals, in such multi-channel encoders. Furthermore, the invention relates to decoders operable to decode signals generated by such multi-channel encoders.

10 BACKGROUND TO THE INVENTION

[0002] Audio recording and reproduction has in recent years progressed from monaural single-channel format to dual-channel stereo format and more recently to multi-channel format, for example five-channel audio format as often used in home movie systems. The introduction of super audio compact disk (SACD) and digital versatile disc (DVD) data carriers has resulted in such five-channel audio reproduction contemporarily gaining interest. Many users presently own equipment capable of providing five-channel audio playback in their homes; correspondingly, five-channel audio program content on suitable data carriers is becoming increasingly available, for example the aforementioned SACD and DVD types of data carriers. On account of growing interest in multi-channel program content, more efficient coding of multi-channel audio program content is becoming an important issue, for example to provide one or more of enhanced quality, longer playing time or even more channels.

[0003] An example of a multichannel encoder is presented in Faller C et al. "Binaural Cue Coding: A Novel and Efficient Representation of Spatial Audio", Audio Engineering Society Convention Paper, New York, NY, US, 10 May 2002, pages 1841-1844, XP001153972.

[0004] Encoders capable of representing spatial audio information such as for audio program content by way of parametric descriptors are known. For example, in a published international PCT patent application no. PCT/IB2003/002858 (WO 2004/008805), encoding of a multi-channel audio signal including at least a first signal component (LF), a second signal component (LR) and a third signal component (RF) is described. This coding utilizes a method comprising steps of:

- 30 (a) encoding the first and second signal components by using a first parametric encoder for generating a first encoded signal (L) and a first set of encoding parameters (P2);
 (b) encoding the first encoded signal (L) and a further signal (R) by using a second parametric encoder for generating a second encoded signal (T) and a second set of encoding parameters (P1) wherein the further signal (R) is derived from at least the third signal component (RF); and
 35 (c) representing the multi-channel audio signal at least by a resulting encoded signal (T) derived from at least the second encoded signal (T), the first set of encoding parameters (P2) and the second set of encoding parameters (P1).

[0005] Parametric descriptions of audio signals have gained interest in recent years because it has been shown that transmitting quantized parameters that describe audio signals requires relative little transmission capacity. These quantized parameters are capable of being received and processed in decoders to regenerate audio signals perceptually not significantly differing from their corresponding original audio signals.

[0006] Contemporary multi-channel encoders generate output encoded data at a bit rate that scales substantially linearly with a number of audio channels conveyed in the output encoded data. Such a characteristic renders inclusion of additional channels problematic because playing duration for a given data carrier storage capacity or quality of audio representation would have to be accordingly sacrificed to accommodate more channels.

SUMMARY OF THE INVENTION

[0007] An object of the present invention is to provide for a multi-channel encoder which is operable to provide more efficient encoding of multi-channel data content, for example multi-channel audio data content.

[0008] The inventors have appreciated that, by use of appropriate encoding methods, output encoded data is capable of conveying information corresponding to, for example, five-channel audio program content, whilst using a bit rate conventionally required to convey two-channel audio program content, namely stereo.

[0009] Thus, according to a first aspect of the present invention, there is provided a multi-channel encoder arranged to process input signals conveyed in N input channels to generate corresponding output signals conveyed in M output channels together with parametric data such that M and N are integers and N is greater than M, the encoder including:

- (a) a down-mixer for down-mixing the input signals to generate corresponding output signals; and

(b) an analyzer for processing the input signals either during down-mixing or as a separate process, said analyzer being operable to generate said parametric data complementary to the output signals, said parametric data describing mutual differences between the N channels of input signal so as to allow substantially for regenerating during decoding of one or more of the N channels of input signal from the M channels of output signal, said output signals being in a form compatible for reproduction in decoders providing for N or for fewer than N output channels to enable backwards compatibility; characterized by the parametric data comprising at least one parameter describing a power of a central channel signal with respect to a power of a right channel signal and a left channel signal for a two channel downmix of the central channel signal, the right channel signal and the left channel signal; the at least one parameter being given by:

$$IID_C = 10 \log_{10} \left(\frac{\varepsilon^2 \sum_k C[k] C^*[k]}{\sum_k L[k] L^*[k] + \sum_k R[k] R^*[k]} \right)$$

where C[k] denotes sample k of the central channel signal C; R[k] denotes sample k of the right signal R, L[k] denotes sample k of the left signal L and ε denotes a weight determining a strength of the central signal in the two channel downmix..

[0010] The invention is of advantage in that the multi-channel encoder is capable of more efficiently encoding multi-channel input signals into an output stream which, for example, can be rendered to be compatible with two-channel stereo playback apparatus.

[0011] Such backwards compatibility of the encoder with earlier types of corresponding decoder is provided in three ways:

- (a) the output down-mixed signals from the encoder are generated in such a way that playback of these signals, namely without additional processing or decoding, results in a spatial image which is a good approximation of, for example, a 5-channel spatial image, given the limitations of a corresponding limited number of loudspeakers. This property assures backward playback compatibility;
- (b) spatial parameters associated with the down-mixed signals are placed in the ancillary data portion of the bit stream. A decoder which is not able to decode the ancillary data portion will still be able to decode the transmitted signal. This property assures backward decoding compatibility; and
- (c) parameters stored in the ancillary part of the bit-stream and the decoder structure are formulated in such a way that a parametric decoder is able to regenerate appropriate 2-, 3- and 4-channel signals. This property provides flexibility in terms of playback system utilized, and hence provides backwards compatibility with 2-, 3- and 4- channel systems.

[0012] Preferably, in the encoder, the analyzer includes processing means for converting the input signals by way of transformation from a temporal domain to a frequency domain and for processing these transformed input signals to generate the parametric data. Processing of the input signals in a frequency domain is of benefit in providing efficient encoding within the encoder. More preferably, in the encoder, at least one of the down-mixer and analyzer are arranged to process the input signals as a sequence of time-frequency tiles to generate the output signals.

[0013] Preferably, in the encoder, the tiles are obtained by transformation of mutually overlapping analysis windows. Such overlapping allows for better continuity and thereby reducing encoding artefacts when the output signals are subsequently decoded to regenerate a representation of the input signals.

[0014] Preferably, the encoder includes a coder for processing the input signals to generate M intermediate audio data channels for inclusion in the M output signals, the analyzer being arranged to output information in the parametric data relating to at least one of:

- (a) inter-channel input signal power ratios or logarithmic level differences ;
- (b) inter-channel coherence between the input signals;
- (c) a power ratio between the input signals of one or more channels and a sum of powers of the input signals of one or more channels; and
- (d) phase differences or time differences between signal pairs.

More preferably, the phase differences in (d) are average phase differences.

[0015] Preferably, in the encoder, calculation of at least one of the phase differences, the coherence data and the

power ratio is followed by principal component analysis (PCA) and/or inter-channel phase alignment to generate the output signals.

[0016] Preferably, to provide a closer resemblance to the original input signals when the input data is regenerated, in the encoder, at least one of the input signals conveyed in the N channels corresponds to an effects channel.

[0017] Preferably, the encoder is adapted to generate the output signals in a form suitable for playback using conventional playback systems.

[0018] According to a second aspect of the invention, there is provided a method of encoding input signals conveyed in N input channels in a multi-channel encoder to generate corresponding output signals conveyed in M output channels together with parametric data such that M and N are integers and N is greater than M, the method including steps of:

- (a) down-mixing the input signals to generate the corresponding output signals; and
- (b) processing in an analyzer the input signals either when being down-mixed or separately, said processing providing said parametric data complementary to the output signals, said parametric data describing mutual differences between the N channels of input data so as to allow substantially for regeneration of the N channels of input signal from the M channels of output signal during decoding, said output signals being in a form compatible for reproduction in decoders providing for N or for fewer than N output channels; characterized by the parametric data comprising at least one parameter describing a power of a central channel signal with respect to a power of a right channel signal and a left channel signal for a two channel downmix of the central channel signal, the right channel signal and the left channel signal; the at least one parameter being given by:

$$IID_C = 10 \log_{10} \left(\frac{\epsilon^2 \sum_k C[k] C^*[k]}{\sum_k L[k] L^*[k] + \sum_k R[k] R^*[k]} \right)$$

where C[k] denotes sample k of the central channel signal C; R[k] denotes sample k of the right signal R, L[k] denotes sample k of the left signal L and ϵ denotes a weight determining a strength of the central signal in the two channel downmix..

[0019] Preferably, the method is adapted to encode input signals corresponding to 5-channels and generate the output signals and parametric data in a form compatible with one or more of corresponding 2-channel stereo decoders, 3 channel decoders and 4-channel decoders.

[0020] Preferably, in the method, the processing includes converting the input signals by way of transformation from a temporal domain to a frequency domain.

[0021] Preferably, in the method, at least one of the input signals is processed as a sequence of time-frequency tiles to generate the output signals.

[0022] Preferably, in the method, the tiles correspond to mutually overlapping analysis windows.

[0023] Preferably, the method includes a step of using a coder for processing the input signals to generate M intermediate audio data channels for inclusion in the output signals, the coder being arranged to output information in the parametric data relating to at least one of:

- (a) inter-channel input signal power ratios or logarithmic level differences;
 - (b) inter-channel coherence between the input signals;
 - (c) a power ratio between the input signals of one or more channels and a sum of powers of the input signals of one or more channels; and
 - (d) phase differences or time differences between signal pairs.
- More preferably, the phase differences in (d) are average phase differences.

[0024] Preferably, in the method, calculation of at least one of the level differences, the coherence data and the power ratio is followed by principal component analysis and/or phase alignment to generate the output signals.

[0025] Preferably, in the method, at least one of the input signals conveyed in the N channels corresponds to an effects channel.

[0026] According to a third aspect of the invention, there is provided encoded data content stored on a data carrier, said data content being generated using the method according to the second aspect of the invention.

[0027] According to a fourth aspect of the invention, there is provided a decoder operable to decode encoded output data as generated by an encoder according to the first aspect of the invention, said encoded output data comprising M channels and associated parametric data generated from input signals of N channels such that $M < N$ where M and N

are integers, the decoder including a processor:

- (a) for receiving the encoded output data and converting it from a time domain to a frequency domain;
- (b) for applying the parametric data in the frequency domain to extract content from the M channels to regenerate from the M channels regenerated data content corresponding to input signals of one or more of N channels not directly included in or omitted from the encoded output data; and
- (c) for processing the regenerated data content for outputting one or more of the regenerated input signals of N channels at one or more outputs of the decoder ;

characterized by the parametric data comprising at least one parameter describing a power of a central channel signal with respect to a power of a right channel signal and a left channel signal for a two channel downmix of the central channel signal, the right channel signal and the left channel signal; the at least one parameter being given by:

$$IID_c = 10 \log_{10} \left(\frac{\varepsilon^2 \sum_k C[k]C^*[k]}{\sum_k L[k]L^*[k] + \sum_k R[k]R^*[k]} \right)$$

where C[k] denotes sample k of the central channel signal C; R[k] denotes sample k of the right signal R, L[k] denotes sample k of the left signal L and ε denotes a weight determining a strength of the central signal in the two channel downmix. Preferably, in the decoder, the processor is operable to apply an all-pass decorrelation filter to obtain decorrelated versions of signals for use in regenerating said one or more input signals of N channels at the decoder.

[0028] Preferably, in the decoder, the processor is operable to apply inverse encoder rotation to split signals of the M channels and decorrelated versions thereof into their constituent components for regenerating said one or more input signals of N channels at the decoder.

[0029] It will be appreciated that features of the invention are susceptible to being combined in any combination without departing from the scope of the invention, which is defined in the claims.

DESCRIPTION OF THE DIAGRAMS

[0030] Embodiments of the invention will now be described, by way of example only, with reference to the following diagrams wherein:

Figure 1 is a schematic diagram of a first multi-channel encoder according to the invention;

Figure 2 is a schematic diagram of a second multi-channel encoder according to the invention including provision for effects, for example low-frequency effects, and

Figure 3 is a schematic diagram of a multi-channel decoder according to the invention, the decoder being complementary to the encoders of Figures 1 and 2 and capable of decoding output data provided from such encoders.

DESCRIPTION OF EMBODIMENTS OF THE INVENTION

[0031] In order to improve encoding executed within a multi-channel encoder provided with N channels of input data and arranged to encode the input data to generate a corresponding encoded output data stream, the inventors have envisaged that the encoder is beneficially operable:

(a) to down-mix the input data of the N channels into M channels such that M<N; and

(b) to generate a relatively small amount of parametric overhead data to combine with data of the M channels when generating the output data stream, the parametric data being arranged to enable reconstruction of data corresponding to the N channels at a subsequent decoder supplied with the output data stream.

[0032] For example, the multi-channel encoder is preferably a five-channel encoder, namely N = 5. The five-channel encoder is configured to down-mix data corresponding to five input channels to generate two channels of intermediate data, namely M = 2. Moreover, the five-channel encoder is operable to generate associated parametric overhead data to combine with data of the two channels to generate the output data stream, the parametric data being sufficient to enable the decoder to reconstruct a representation of the five input channels. The decoder is of benefit in that it is capable

of being backwards compatible to support situations where $N = 2, 3, 4$, namely backwards compatible with 2-channel, 3-channel and 4-channel output situations.

[0033] In a preferred embodiment of the invention, an encoder is operable to process N input data channels. The N input channels preferably correspond to a center audio data channel, a left-front audio data channel, a left-rear audio data channel, a right-front audio data channel and a right rear audio data channel; such five channels are capable of creating an apparent 3-dimensional distribution of sound appropriate for domestic cinema-type programme content reproduction. The N input data channels are down-mixed into two intermediate audio data channels, for example encoded using a contemporary stereo audio coder. The coder beneficially employs principal component analysis and/or phase alignment of the left-front and the left-rear data channels. The encoder is also arranged to employ a separate principal component analysis and/or phase alignment on the right-front and the right-rear input channels. Moreover, the encoder is operable to generate parametric overhead data including information relating to the following:

- (a) inter-channel level differences between the left-front and left-rear data channels;
- (b) inter-channel level differences between the right-front and right-rear data channels;
- (c) inter-channel coherence data relating to the left-front and left-rear channels;
- (d) inter-channel coherence data relating to the right-front and right-rear data channels; and
- (e) a power ratio between the center data channel and a sum of powers of the left-front, left-rear, right-front and right rear data channels.

[0034] The two intermediate data channels and the parametric overhead data are combined to generate encoded output data from the encoder. Optionally, data relating to inter-channel phase differences and preferably overall phase differences between the left-front and left-rear data channels on the one hand, and right-front and right-rear data channels on the other hand are included in the encoded output data from the encoder. Parametric analysis performed in (a) to (e) with regard to this example embodiment of the invention preferably involves temporal and frequency analysis; more preferably, the analysis is performed by way of time-frequency tiles as will be further elucidated later.

[0035] Operation of the encoder in the preferred embodiment of the invention will now be described in greater detail in terms of its associated mathematical functions with reference to Figure 1 whose parts and signals are defined as provided in Table 1.

Table 1:

10	Encoder	320	Centre signal, S_c
20	First channel	330	Right front signal, S_{rf}
30	Second channel	340	Right rear signal, S_{rr}
40	Third channel	350	Left front transformed signal, TS_{if}
100	Segment and transform unit	360	Left rear transformed signal, TS_{lr}
110	Parameter analysis unit	370	First parameter set, PS 1
120	Parameter-to-down-mix vector unit	380	Left intermediate signal, LI
130	Down-mix unit	400	Centre intermediate signal, CI
140	Segment and transform unit	410	Right front transformed signal, TS_{rf}
150	Segment and transform unit	420	Right rear transformed signal, TS_{rr}
160	Parameter analysis unit	430	Second parameter set, PS2
170	Parameter-to-down-mix vector unit	440	Right intermediate signal, RI
180	Down-mix unit	450	Third parameter set, PS3
200	Mixing and parameter extraction unit	460	Right pre-output signal, PR_{out}
210	Inverse transform and OLA unit	470	Left pre-output signal, PL_{out}
300	Left front input signal, S_{if}	480	Right output signal, R_{out}
310	Left rear input signal, S_{lr}	490	Left output signal, L_{out}

[0036] In Figure 1, there is shown an encoder indicated generally by 10. The encoder 10 comprises first, second and third input channels 20, 30, 40 respectively. Output signals 380, 400, 440, namely LI, CI, RI, from these three channels

20, 30, 40 respectively are coupled to a mixing and parameter extraction unit 200. The extraction unit 200 comprises associated right and left pre-output signals 460, 470, namely PR_{out} , PL_{out} , which are connected to an inverse transform and OLA unit 210 for generating encoded right and left output signals 480, 490, namely R_{out} , L_{out} respectively.

[0037] The first channel 20 includes a segment and transform unit 100 for receiving left front and left rear input signals 300, 310 respectively, namely S_{lf} , S_{lr} . Corresponding left front and left rear transformed signals 350, 360, namely TS_{lf} , TS_{lr} , are coupled to a down-mix unit 130 of the channel 20, and also to parameter analysis unit 110 of the channel 20. A first parameter set signal 370, namely PS1, is coupled to an input of the parameter-to-down-mix vector conversion unit 120 whose corresponding output is coupled to the down-mix unit 130.

[0038] The second channel 30 includes a segment and transform unit 140 arranged to receive a center input signal 320, namely S_c . The center intermediate signal 400, namely CI, is coupled from the transform unit 140 to the parameter extraction unit 200 as described in the foregoing.

[0039] The third channel 40 includes a segment and transform unit 150 for receiving right front and right rear input signals 330, 340 respectively, namely S_{rf} , S_{rr} . Corresponding right front and right rear transformed signals 410, 420, namely TS_{rf} , TS_{rr} , are coupled to a down-mix unit 180 of the channel 40, and also to parameter analysis unit 160 of the channel 40. A second parameter set signal 430, namely PS2, is coupled to an input of the parameter-to-down-mix vector conversion unit 170 whose corresponding output is coupled to the down-mix unit 180.

[0040] The Parameter extraction unit 200 is arranged to receive signal 380, 400, 440 from the channels 20, 30, 40 to generate the third parameter set output 450, namely PS3, as well as the pre-output signals 470, 460, namely PR_{out} , PL_{out} for the OLA unit 210.

[0041] The encoder 10 is susceptible to being implemented in dedicated hardware. Alternatively, the encoder 10 can be based on computer hardware arranged to execute software for implementing processing functions of the encoder 10. As a further alternative, the encoder 10 can be implemented by a combination of dedicated hardware coupled to computer hardware operating under software control.

[0042] Operation of the encoder 10 will now be described with reference to Figure 1. The signals $S_{lf}[n]$, $S_{lr}[n]$, $S_{rf}[n]$, $S_{rr}[n]$, $S_c[n]$ describe discrete temporal waveforms for left-front, left-rear, right-front, right-rear and centre audio signals respectively. In the channels 20, 30, 40, these five signals are segmented using a common segmentation, preferably using overlapping analysis windows. Subsequently, each segment is converted from a temporal domain to a frequency domain using a complex transform, for example a Fourier transform or equivalent type of transform; alternatively, complex filter-bank structures, for example implemented using at least one of hardware or simulated in software, may be employed to obtain time/frequency tiles. Such signal processing results in segmented sub-band representations of the input signals in frequency domain denoted by $L_f[k]$, $L_r[k]$, $R_f[k]$, $R_r[k]$, $C[k]$ wherein a parameter k denotes a frequency index, L denotes left, R denotes right, f denotes front, r denotes rear and C denotes center.

[0043] In the parameter extraction unit 200, data processing is executed in a first step to estimate relevant parameters between left-front and left-rear signals. These parameters include a level difference IID_L , a phase difference IPD_L and a coherence ICC_L . Preferably, the phase difference IPD_L corresponds to an average phase difference. Moreover, these parameters IID_L , IPD_L and ICC_L are calculated as provided in Equations 1 to 3 (Eq. 1 to 3):

$$IID_L = 10 \log_{10} \left(\frac{\sum_k L_f[k] L_f^*[k]}{\sum_k L_r[k] L_r^*[k]} \right) \quad \text{Eq. 1}$$

$$IPD_L = \angle \left(\frac{\sum_k L_f[k] L_r^*[k]}{\sqrt{\sum_k L_f[k] L_f^*[k] \sum_k L_r[k] L_r^*[k]}} \right) \quad \text{Eq. 2}$$

$$ICC_L = \left(\frac{\sum_k L_f[k] L_r^*[k]}{\sqrt{\sum_k L_f[k] L_f^*[k] \sum_k L_r[k] L_r^*[k]}} \right) \quad \text{Eq. 3}$$

wherein a symbol * denotes a complex conjugate.

[0044] The processes described by Equations 1 to 3 is also repeated for right-front and right-rear signals, such processing resulting in corresponding parameters IID_R , IPD_R and ICC_R relating to level difference, phase difference and coherence respectively.

[0045] In the parameter-to-down-mix vector conversion unit 120, data processing is executed in a second step to compute complex weights for the down-mix of the two signals left-front L_f and left-rear L_r . In the preferred embodiment, the down-mix vector sent to the down-mix unit 130 is arranged to maximize the energy of the down-mix signal $Y[k]$ by applying a rotation α of the input signal space and/or complex phase alignment.

[0046] The down-mix is applied as follows. The two signals L_f and L_r are rotated to obtain a dominant signal $Y[k]$ and a corresponding residual signal $Q[k]$ using a rotation angle α which maximizes the energy of the dominant signal $Y[k]$ as depicted by Equation 4 (Eq. 4):

$$\begin{bmatrix} Y[k] \\ Q[k] \end{bmatrix} = \begin{bmatrix} \cos\alpha & \sin\alpha \\ -\sin\alpha & \cos\alpha \end{bmatrix} \begin{bmatrix} L_f[k] \exp(j(-OPD_L)) \\ L_r[k] \exp(j(-OPD_L + IPD_L)) \end{bmatrix} \quad \text{Eq. 4}$$

wherein an angle OPD_L denotes an overall phase rotation angle, whilst the phase difference IPD_L is calculated to ensure a maximum phase-alignment of the two signals L_f , L_r . The rotation angle α is calculable from the extracted parameters using Equations 5 and 6 (Eq. 5 and 6):

$$\alpha = \frac{1}{2} \arctan\left(\frac{2gICC_L}{g^2 - 1}\right) \quad \text{Eq. 5}$$

wherein

$$g = 10^{\frac{IID_L}{20}} \quad \text{Eq.6}$$

[0047] The signal $Q[k]$ from Equation 4 is subsequently discarded in the parameter extraction unit 200, the signal $Y[k]$ is scaled by a scalar β to obtain the signal $L[k]$ in such a way that the signal $L[k]$ has a similar power to that of the signal $Q[k]$ plus the power of the signal $Y[k]$; in other words, the signal $Q[k]$ is discarded whilst a corresponding loss in signal power arising is compensated by scaling the signal $Y[k]$. The scalar β is calculable using Equations 7 and 8 (Eq. 7 and 8):

$$\beta = \sqrt{1 + \frac{1 - \sqrt{\mu}}{1 + \sqrt{\mu}}} \quad \text{Eq. 7}$$

wherein

$$\mu = 1 + \frac{4ICC_L^2 - 4}{\left(g + \frac{1}{g}\right)^2} \quad \text{Eq. 8}$$

[0048] The first and second steps are also repeated for the right-front and right-rear signal pairs, resulting in generation of the corresponding signal R[k]. It is to be noted that the use of PCA rotation can be circumvented by using a fixed value for the rotation angle α .

[0049] A third processing step executed within the encoder 10 involves mixing the center signal C[k] into both of the signals L[k] and R[k] resulting in generation of the pre-output signals 470, 460 respectively, namely PL_{out}, PR_{out}. Such mixing is executed according to Equation 9 (Eq. 9):

$$\begin{bmatrix} PL_{out}[k] \\ PR_{out}[k] \end{bmatrix} = \begin{bmatrix} L[k] + \varepsilon C[k] \\ R[k] + \varepsilon C[k] \end{bmatrix} \quad \text{Eq. 9}$$

wherein a parameter ε denotes a weight determining the strength of the signal C[k] in mixing associated with Equation 9, for example $\varepsilon = 0.707$ typically. Preferably, respective combinations of L, C and R are aligned in terms of phase, otherwise phase cancellation would occur.

[0050] A parameter IID_C describing the power of signal C with respect to the power of signals L and R is calculable from Equation 10 (Eq. 10):

$$IID_C = 10 \log_{10} \left(\frac{\varepsilon^2 \sum_k C[k]C^*[k]}{\sum_k L[k]L^*[k] + \sum_k R[k]R^*[k]} \right) \quad \text{Eq. 10}$$

[0051] The foregoing process comprising the aforementioned first, second and third steps is repeated in the encoder 10 for each time/frequency tile.

[0052] The signals PL_{out}[k] and PR_{out}[k] are subsequently transformed in the encoder to a temporal domain and combined with previous segments using an overlap-add type of summation to generate the aforesaid output signals 490, 480 respectively, namely L_{out}, R_{out}.

[0053] Output data from the encoder 10 is susceptible to being communicated by way of a communication network, for example via the Internet or other similar broadcast network. Alternatively, or additionally, the output data is capable of being conveyed by way of a data carrier, for example a DVD optical data disk or other similar type of data carrying medium.

[0054] The output data from the encoder 10 is capable of being decoded in decoders compatible with the encoder 10, for example in a decoder indicated generally by 800 in Figure 3. The decoder 800 includes a data processing unit 810 for subjecting output signals 480, 490 and associated parameter data 370, 430, 450, 690 received from the encoders 10, 600 to various mathematical operations to generate corresponding decoded output signals (DOP).

[0055] In order to provide backwards compatibility, such decoders can be at least one of stereo, 3-channel and 5-channel apparatus. In a stereo-type decoder compatible with the encoder 10, namely where decoder 800 includes only two decoded outputs for DOP, the stereo-type decoder having two playback channels, the signals R_{out}, L_{out} provided from the encoder 10 are reproduced in the stereo-type decoder over two playback channels without further processing being performed.

[0056] In a 3-channel decoder compatible with the encoder 10, the decoder having three playback channels, namely where the decoder 800 includes three decoded outputs for DOP, the two signals R_{out}, L_{out}, for example read from a data carrier such as a DVD optical disk, are segmented and then transformed to the aforementioned frequency domain. Corresponding recreated signals L[k], R[k] and C[k] are then derived using Equations 11 to 16 (Eq. 11 to 16):

$$\begin{bmatrix} L[k] \\ R[k] \\ C[k] \end{bmatrix} = \begin{bmatrix} w_L L_{out} \\ w_R R_{out} \\ w_{LC} L_{out} + w_{RC} R_{out} \end{bmatrix} \quad \text{Eq. 11}$$

wherein

$$w_{LC} = \frac{0.5}{\epsilon} \sqrt{\frac{\sigma_C^2}{\sigma_L^2}} \quad \text{Eq. 12}$$

$$w_{RC} = \frac{0.5}{\epsilon} \sqrt{\frac{\sigma_C^2}{\sigma_L^2}} \quad \text{Eq. 13}$$

$$\sigma_L^2 = \sum_k L[k] L^*[k] \quad \text{Eq. 14}$$

$$\sigma_R^2 = \sum_k R[k] R^*[k] \quad \text{Eq. 15}$$

$$\sigma_C^2 = \frac{\sigma_L^2 + \sigma_R^2}{2 + 10^{-10} \frac{-IID_C}{-10}} \quad \text{Eq. 16}$$

[0057] Three-channel audio signals for user-appreciation are then derived from the signals L[k], R[k] and C[k] in a manner similar to that described in the foregoing.

[0058] In a five-channel decoder compatible with the encoder 10, namely the decoder 800 providing five decoded outputs, a three-channel playback reconstruction as described in the foregoing is employed resulting in regeneration of the signals L[k], R[k] and C[k] at the decoder. In the five-channel decoder, a further step is executed which involves splitting the signal L[k] in its constituent components, namely a front left component L_f[k] and a rear left component L_r[k]; similarly, the signal R[k] is also split into its constituent components, namely a front right component R_f[k] and a rear right component R_r[k]. Such signal splitting utilizes an inverse encoder rotation operation complementary to the rotation performed in the encoder 10 as described in the foregoing. The dominant signal Y[k] and the residual signal Q[k] required for the inverse rotation are derived in the five-way decoder using Equations 17 and 18 (Eq. 17, 18):

$$\begin{bmatrix} Y[k] \\ Q[k] \end{bmatrix} = \begin{bmatrix} L[k] \cos \gamma \\ H[k] L[k] \sin \gamma \end{bmatrix} \quad \text{Eq. 17}$$

wherein

$$\gamma = \arctan\left(\frac{1 - \sqrt{\mu}}{1 + \sqrt{\mu}}\right) \quad \text{Eq. 18}$$

for which the parameter μ is previous defined in Equation 8 (Eq. 8) in the foregoing. In Equation 17, $H[k]$ denotes an all-pass decorrelation filter to obtain a decorrelated version of the signal $L[k]$. Subsequently, the signals $L_f[k]$ and $L_r[k]$ are generated using an inverse encoder rotation function as described by Equation 19 (Eq. 19):

$$\begin{bmatrix} L_f[k] \\ L_r[k] \end{bmatrix} = \begin{bmatrix} \cos\alpha & -\sin\alpha \\ \sin\alpha & \cos\alpha \end{bmatrix} \begin{bmatrix} \exp(jOPD_L) & 0 \\ 0 & \exp(jOPD_L - IPD_L) \end{bmatrix} \begin{bmatrix} Y[k] \\ Q[k] \end{bmatrix} \quad \text{Eq. 19}$$

[0059] Similar processing is also applied for right hand channel components.

[0060] In a four-channel decoder compatible with the encoder 10, the four-channel decoder is operable to firstly decode five channels in a manner akin to that employed in the aforementioned five-channel decoder to generate five audio signals S_{lf} , S_{lr} , S_{rf} , S_{rr} and S_C . Thereafter, simple mixing occurs according to Equations 20 and 21 (Eq. 20, 21) to generate left-front and right-front audio signals $S_{lf,playback}$, $S_{rf,playback}$ for user appreciation:

$$S_{lf,playback} = S_{lf} + qS_C \quad \text{Eq. 20}$$

$$S_{rr,playback} = S_{rf} + qS_C \quad \text{Eq. 21}$$

wherein a coefficient $q = 0.707$.

[0061] The coefficient q ensures for the four-channel decoder that the total power of the center signal components is substantially constant, irrespective of playback through a single center loudspeaker or as a phantom apparent source of sound for the user created by left front and right front loudspeakers coupled to the four-channel decoder.

[0062] It will be appreciated that embodiments of the invention described in the foregoing are susceptible to being modified without departing from the scope of the invention as defined by the accompanying claims.

[0063] The inventors have identified that the encoder 10 does not support coding of an effects channel (LFE), for example a low frequency effects channel. Such a LFE channel is of benefit, for example, for conveying sound effects information such as thunder-sound information or explosion sound information which beneficially accompanies visual information simultaneously presented to users in, for example, a home movie system. Thus, the inventors have appreciated in an embodiment of the present invention that it is beneficial to modify the encoder 10 to enhance its second channel 30 and thereby generate an encoder as depicted in Figure 2 and indicated therein generally by 600. Optionally, the LFE channel has a relatively restricted frequency bandwidth of substantially 120 Hz although selective relatively greater bandwidths are also capable of being accommodated.

[0064] The encoder 600 is generally similar to the encoder 10 except that the second channel 30 of the encoder 600 is furnished with a parameter analysis unit 630, a parameter to down-mix vector unit 640 and a down-mix unit 650 connected in a similar manner to corresponding components of the first and third channels 20, 40 respectively; the channel 30 of the encoder 600 is operable to output a fourth parameter set 690, namely PS4. Moreover, the second channel 30 of the encoder 600 includes a low frequency effects (lfe) input 610 for receiving a low frequency effects signal S_{lfe} , and also an input 620 for receiving the aforementioned center signal S_C . Preferably, processing of the signal S_{lfe} is limited to a frequency bandwidth of 120 Hz from sub-audio frequencies upwards and therefore potentially suitable for driving contemporary sub-woofer type loudspeakers. However, embodiments of the invention are susceptible to being implemented with the second channel 30 having a much greater bandwidth than 120 Hz, for example to provide high frequency signal information corresponding to impulse-like sounds.

[0065] Inclusion of low frequency effect information in output from the encoder 600 requires use of additional parameters in comparison to the encoder 10. A signal presented to the input 610 is analyzed in the encoder 600 to determine corresponding representative parameters which are analyzed on a time/frequency tile basis in a similar manner to other

aforementioned audio signals processed through the encoder 10. Corresponding decoders are preferably arranged to include additional features for decoding the low frequency information to regenerate, for example, a signal suitable for amplification to drive audio sub-woofer loudspeakers in home movie systems.

[0066] In the accompanying claims, numerals and other symbols included within brackets are included to assist understanding of the claims and are not intended to limit the scope of the claims in any way.

[0067] Expressions such as "comprise", "include", "incorporate", "contain", "is" and "have" are to be construed in a non-exclusive manner when interpreting the description and its associated claims, namely construed to allow for other items or components which are not explicitly defined also to be present. Reference to the singular is also to be construed to be a reference to the plural and vice versa.

Claims

1. A multi-channel encoder (10; 600) arranged to process input signals (300, 310, 320, 330, 340; 300, 310, 610, 620, 330, 340) conveyed in N input channels to generate corresponding output signals (480, 490) conveyed in M output channels together with parametric data (450) such that M and N are integers and N is greater than M, the encoder including:

- (a) a down-mixer for down-mixing the input signals to generate corresponding output signals; and
- (b) an analyzer for processing the input signals either during down-mixing or as a separate process, said analyzer being operable to generate said parametric data complementary to the output signals, said parametric data describing mutual differences between the N channels of input signal so as to allow substantially for regenerating during decoding of one or more of the N channels of input signal from the M channels of output signal, said output signals being in a form compatible for reproduction in decoders providing for N or for fewer than N output channels to enable backwards compatibility; **characterized by** the parametric data comprising at least one parameter describing a power of a central channel signal with respect to a power of a right channel signal and a left channel signal for a two channel downmix of the central channel signal, the right channel signal and the left channel signal; the at least one parameter being given by:

$$IID_C = 10 \log_{10} \left(\frac{\epsilon^2 \sum_k C[k] C^*[k]}{\sum_k L[k] L^*[k] + \sum_k R[k] R^*[k]} \right)$$

wherein a symbol * denotes a complex conjugate, where C[k] denotes sample k of the central channel signal C; R[k] denotes sample k of the right signal R, L[k] denotes sample k of the left signal L and ϵ denotes a weight determining a strength of the central signal in the two channel downmix.

2. An encoder according to Claim 1, wherein the encoder is a 5-channel encoder arranged to generate the output signals and parametric data in a form compatible with at least one of corresponding 2-channel stereo decoders, 3 channel decoders and 4-channel decoders.

3. An encoder according to Claim 1, wherein the analyzer includes processing means for converting the input signals by way of transformation from a temporal domain to a frequency domain and for processing these transformed input signals to generate the parametric data.

4. An encoder according to Claim 3, wherein at least one of the down-mixer and the analyzer are arranged to process the input signals as a sequence of time-frequency tiles to generate the output signals.

5. An encoder according to Claim 4, wherein the tiles are obtained by transformation of mutually overlapping analysis windows.

6. An encoder according to Claim 1, including a coder for processing the input signals to generate M intermediate audio data channels for inclusion in the M output signals, the analyzer being arranged to output information in the

parametric data relating to at least one of:

- (a) inter-channel input signal power ratios or logarithmic level differences;
- (b) inter-channel coherence between the input signals;
- (c) a power ratio between the input signals of one or more channels and a sum of powers of the input signals of one or more channels; and
- (d) phase differences or time differences between signal pairs.

7. An encoder according to Claim 6, wherein in (d) said phase differences are average phase differences.
8. An encoder according to Claim 6, wherein calculation of at least one of the phase differences, coherence data and the power ratios is followed by principal component analysis (PCA) and/or inter-channel phase alignment to generate the N output signals.
9. An encoder according to Claim 1, wherein at least one of the input signals conveyed in the N channels corresponds to an effects channel.
10. An encoder according to Claim 1 adapted to generate the output signals in a form suitable for playback using conventional playback systems.
11. A method of encoding input signals conveyed in N input channels in a multi-channel encoder to generate corresponding output signals conveyed in M output channels together with parametric data such that M and N are integers and N is greater than M, the method including steps of:

- (a) down-mixing the input signals to generate the corresponding output signals; and
- (b) processing in an analyzer the input signals when being down-mixed or separately, said processing providing said parametric data complementary to the output signals, said parametric data describing mutual differences between the N channels of input signal so as to allow substantially for regeneration of the N channels of input signal from the M channels of output signal during decoding, said output signals being in a form compatible for reproduction in decoders providing for N or for fewer than N channels; **characterized by** the parametric data comprising at least one parameter describing a power of a central channel signal with respect to a power of a right channel signal and a left channel signal for a two channel downmix of the central channel signal, the right channel signal and the left channel signal; the at least one parameter being given by:

$$IID_C = 10 \log_{10} \left(\frac{\epsilon^2 \sum_k C[k] C^*[k]}{\sum_k L[k] L^*[k] + \sum_k R[k] R^*[k]} \right)$$

, wherein a symbol * denotes a complex conjugate,

where C[k] denotes sample k of the central channel signal C; R[k] denotes sample k of the right signal R, L[k] denotes sample k of the left signal L and ε denotes a weight determining a strength of the central signal in the two channel downmix.

12. A method according to Claim 11, adapted to encode input signals corresponding to 5-channels and generate the output signals and parametric data in a form compatible with one or more of corresponding 2-channel stereo decoders, 3 channel decoders and 4-channel decoders.
13. A method according to Claim 11, wherein said processing includes converting the input signals by way of transformation from a temporal domain to a frequency domain.
14. A method according to Claim 13, wherein at least one of the input signals are processed as a sequence of time-frequency tiles to generate the output signals.
15. A method according to Claim 14, wherein the tiles correspond to mutually overlapping analysis windows.

16. A method according to Claim 11, the method including a step of using a coder for processing the input signals to generate M intermediate audio data channels for inclusion in the output signals, the coder being arranged to output information in the parametric data relating to at least one of:

- (a) inter-channel input power ratios or logarithmic level differences;
- (b) inter-channel coherence between the input signals;
- (c) a power ratio between the input signals of one or more channels and a sum of powers of the input signals of one or more channels; and
- (d) power differences or time differences between signal pairs.

17. A method according to Claim 16, wherein the power differences are average power differences.

18. A method according to Claim 16, wherein calculation of at least one of the phase difference, the coherence data and the power ratio is followed by principal component analysis (PCA) and/or inter-channel phase alignment to generate the output signals.

19. A method according to Claim 11, wherein at least one of the input signals conveyed in the N channels corresponds to an effects channel.

20. Encoded data content being generated using the method of Claim 11.

21. Data carrier on which encoded data as claimed in Claim 20 is stored.

22. A decoder (800) operable to decode encoded output data (370, 430, 450, 480, 490, 690) as generated by an encoder (10; 600) according to Claim 1, said encoded output data (370, 430, 450, 480, 490, 690) comprising M channels (480, 490) and associated parametric data (370, 430, 450, 690) generated from input signals of N channels such that $M < N$ where M and N are integers, the decoder (800) including a processor (810):

- (a) for receiving the encoded output data (370, 430, 450, 460, 490, 690) and converting it from a time domain to a frequency domain;
- (b) for applying the parametric data in the frequency domain to extract content from the M channels to regenerate from the M channels regenerated data content corresponding to input signals of one or more of N channels not directly included in or omitted from the encoded output data; and
- (c) for processing the regenerated data content for outputting one or more of the regenerated input signals of N channels at one or more outputs of the decoder; **characterized by** the parametric data comprising at least one parameter describing a power of a central channel signal with respect to a power of a right channel signal and a left channel signal for a two channel downmix of the central channel signal, the right channel signal and the left channel signal; the at least one parameter being given by:

$$IID_C = 10 \log_{10} \left(\frac{\epsilon^2 \sum_k C[k] C^*[k]}{\sum_k L[k] L^*[k] + \sum_k R[k] R^*[k]} \right)$$

, wherein a symbol * denotes a complex conjugate,

where C[k] denotes sample k of the central channel signal C; R[k] denotes sample k of the right signal R, L[k] denotes sample k of the left signal L and ϵ denotes a weight determining a strength of the central signal in the two channel downmix.

23. A decoder (800) according to Claim 22, wherein said processor (810) is operable to apply an all-pass decorrelation filter to obtain decorrelated versions of signals for use in regenerating said one or more input signals of N channels at the decoder.

24. A decoder (800) according to Claim 23, wherein the processor is operable to apply inverse encoder rotation to split signals of the M channels and decorrelated versions thereof into their constituent components for regenerating said

one or more input signals of N channels at the decoder.

25. A decoder (800) according to Claim 24, said decoder (800) being operable to generate its one or more decoder outputs (1300 to 1340) solely from said encoded output data (450, 480, 490) received at the decoder (800).

5

Patentansprüche

1. Mehrkanalcodierer (10; 600) vorgesehen zum Verarbeiten von Eingangssignalen (300, 310, 320, 330, 340; 300, 310, 610, 620, 330, 340) transportiert in N Eingangskanälen zum Erzeugen entsprechender Ausgangssignale (480, 490), transportiert in M Ausgangskanälen, zusammen mit parametrischen Daten (450), so dass M und N ganze Zahlen sind und N größer ist als M, wobei der Codierer Folgendes enthält:

10

- (a) einen Heruntermischer zum Heruntermischen der Eingangssignale zum Erzeugen entsprechender Ausgangssignale, und
 (b) einen Analysator zum Verarbeiten der Eingangssignale entweder während der Heruntermischung oder als Einzelprozess, wobei der genannte Analysator wirksam ist zum Erzeugen der genannten parametrischen Daten komplementär zu den Ausgangssignalen,

15

wobei die genannten parametrischen Daten Unterschiede zwischen den N Kanälen des Eingangssignals beschreiben, damit im Wesentlichen eine Regeneration während der Decodierung eines oder mehrerer der N Kanäle des Eingangssignals aus den M Kanälen des Ausgangssignals ermöglicht wird, wobei die genannten Ausgangssignale in einer Form sind, die kompatibel ist zur Reproduktion in Decodern, die N oder weniger als N Ausgangskanäle schaffen um eine Rückwärtskompatibilität zu ermöglichen, **dadurch gekennzeichnet, dass** die parametrischen Daten wenigstens einen Parameter enthalten, der die Leistung eines Zentralkanalsignals gegenüber der Leistung eines Rechtskanalsignals und eines Linkskanalsignals für eine Zweikanalheruntermischung des Zentralkanalsignals, des Rechtskanalsignals und des Linkskanalsignals beschreibt; wobei der wenigstens eine Parameter gegeben wird durch:

20

25

30

$$IID_C = 10 \log_{10} \left(\frac{\varepsilon^2 \sum_k C[k] C^*[k]}{\sum_k L[k] L^*[k] + \sum_k R[k] R^*[k]} \right)$$

35

wobei ein Symbol * eine konjugierte Zahl bezeichnet,
 wobei C[k] den Abtastwert k des Zentralkanalsignals C bezeichnet, wobei R[k] den Abtastwert k des Rechtssignals R bezeichnet, wobei L[k] den Abtastwert des Linkssignals L bezeichnet und wobei ε eine Gewichtung bezeichnet, die eine Stärke des Zentralsignals in der Zweikanalheruntermischung bezeichnet.

40

2. Codierer nach Anspruch 1, wobei der Codierer ein 5-Kanalcodierer ist, vorgesehen zum Erzeugen der Ausgangssignale und parametrischen Daten in einer Form, die mit wenigstens einem Decoder von entsprechenden 2-Kanal-Stereo-Decodern, 3-Kanaldecodern und 4-Kanaldecodern kompatibel ist

45

3. Codierer nach Anspruch 1, wobei der Analysator Verarbeitungsmittel zum Umwandeln der Eingangssignale durch Transformation aus einer zeitlichen Domäne in eine Frequenzdomäne und zum Verarbeiten dieser transformierten Eingangssignale zum Erzeugen der parametrischen Daten aufweist.

50

4. Codierer nach Anspruch 3, wobei wenigstens der Abwärtsmischer oder der Analysator dazu vorgesehen sind, die Eingangssignale als eine Folge von Zeit-Frequenzfliesen zum Erzeugen der Ausgangssignale zu verarbeiten.

5. Codierer nach Anspruch 4, wobei die Tiles durch Transformation einander überlappender Analysenfenster erhalten werden .

55

6. Codierer nach Anspruch 1, mit einem Codierer zum Verarbeiten der Eingangssignale zum Erzeugen von M Zwischenaudiodatenkanäle zum Einschließen in die M Ausgangssignale, wobei der Analysator dazu vorgesehen ist, Information in den parametrischen Daten auszuliefern, und zwar in Bezug auf:

EP 1 735 774 B1

- (a) Interkanaleingangssignalleistungsverhältnisse oder logarithmische Pegeldifferenzen;
(b) Interkanalkohärenz zwischen den Eingangssignalen,
(c) ein Leistungsverhältnis zwischen den Eingangssignalen eines oder mehrerer Kanäle und einer Summe von Leistungen der Eingangssignale eines oder mehrerer Kanäle; und
(d) Phasendifferenzen oder Zeitdifferenzen zwischen Signalpaaren.

7. Codierer nach Anspruch 6, wobei in (d) die genannten Phasendifferenzen mittlere Phasendifferenzen sind.
8. Codierer nach Anspruch 6, wobei der Berechnung wenigstens einer der Phasendifferenzen, der Kohärenzdaten und der Leistungsverhältnisse eine grundsätzliche Komponentenanalyse (PCA) und/oder eine Interkanalphaseausrichtung folgt, und zwar zum Erzeugen der N Ausgangssignale.
9. Codierer nach Anspruch 1, wobei wenigstens eines der Eingangssignale, die in den N Kanälen transportiert werden, einem Effektekanal entspricht.
10. Codierer nach Anspruch 1, vorgesehen zum Erzeugen der Ausgangssignale in einer Form, geeignet zur Wiedergabe, und zwar unter Anwendung herkömmlicher Wiedergabesysteme.
11. Verfahren zum Codieren von Eingangssignalen, transportiert in N Eingangskanälen in einem Mehrkanalcodierer zum Erzeugen entsprechender Ausgangssignale, transportiert in M Ausgangskanälen zusammen mit parametrischen Daten, so dass M und N ganze Zahlen sind und N größer ist als M, wobei das Verfahren die nachfolgenden Verfahrensschritte umfasst:

- (a) das Heruntermischen der Eingangssignale zum Erzeugen der entsprechenden Ausgangssignale, und
(b) das Verarbeiten der Eingangssignale in einem Analysator entweder während der Heruntermischung oder als Einzelprozess, wobei die Verarbeitung die genannten parametrischen Daten schafft, und zwar komplementär zu den Ausgangssignalen, wobei die genannten parametrischen Daten Unterschiede zwischen den N Kanälen des Eingangssignals beschreiben, damit im Wesentlichen eine Regeneration während der Decodierung eines oder mehrerer der N Kanäle des Eingangssignals aus den M Kanälen des Ausgangssignals ermöglicht wird, wobei die genannten Ausgangssignale in einer Form sind, die kompatibel ist zur Reproduktion in Decodern, die N oder weniger als N Ausgangskanäle schaffen, **dadurch gekennzeichnet, dass** die parametrischen Daten wenigstens einen Parameter enthalten, der die Leistung eines Zentralkanalsignals gegenüber der Leistung eines Rechtskanalsignals und eines Linkskanalsignals für eine Zweikanalheruntermischung des Zentralkanalsignals, des Rechtskanalsignals und des Linkskanalsignals beschreibt; wobei der wenigstens eine Parameter gegeben wird durch:

$$IID_C = 10 \log_{10} \left(\frac{\varepsilon^2 \sum_k C[k] C^*[k]}{\sum_k L[k] L^*[k] + \sum_k R[k] R^*[k]} \right)$$

wobei ein Symbol * eine konjugierte Zahl bezeichnet,
wobei C[k] den Abtastwert k des Zentralkanalsignals C bezeichnet, wobei R[k] den Abtastwert k des Rechtssignals R bezeichnet, wobei L[k] den Abtastwert des Linkssignals L bezeichnet und wobei ε eine Gewichtung bezeichnet, die eine Stärke des Zentralsignals in der Zweikanalheruntermischung bezeichnet.

12. Verfahren nach Anspruch 11, vorgesehen zum Codieren von Eingangssignalen entsprechend 5-Kanälen und zum Erzeugen der Ausgangssignale und parametrischer Daten in einer Form, die mit einem oder mehreren entsprechenden 2-Kanal-Stereodecodern, 3-Kanaldecodern und 4-Kanaldecodern kompatibel ist.
13. Verfahren nach Anspruch 11, wobei die genannte Verarbeitung das Umwandeln der Eingangssignale durch Transformation aus einer Zeitdomäne in eine Frequenzdomäne.
14. Verfahren nach Anspruch 13, wobei wenigstens eines der Eingangssignale als eine Sequenz Zeit-Frequenzfließen verarbeitet werden, und zwar zum Erzeugen der Ausgangssignale.

EP 1 735 774 B1

15. Verfahren nach Anspruch 14, wobei die Fliesen mit einander überlappenden Analysenfenstern übereinstimmen.
16. Verfahren nach Anspruch 11, wobei das Verfahren einen Verfahrensschritt der Verwendung eines Codierers umfasst zum Verarbeiten der Eingangssignale zum Erzeugen von M Zwischen-Audiodatenkanälen zum Einschließen in die Ausgangssignale, wobei der Codierer dazu vorgesehen ist, Information in den parametrischen Daten auszuliefern, die sich auf wenigstens eines der nachfolgenden Verhältnisse beziehen:
- (a) Zwischenkanaleingangsleistungsverhältnisse oder logarithmische Pegeldifferenzen;
 - (b) Zwischenkanalkohärenz zwischen den Eingangssignalen;
 - (c) ein Leistungsverhältnis zwischen den Eingangssignalen eines oder mehrerer Kanäle und eine Summe von Leistungen der Eingangssignale eines oder mehrerer Kanäle; und
 - (d) Leistungsdifferenzen oder Zeitdifferenzen zwischen Signalpaaren.
17. Verfahren nach Anspruch 16, wobei die Leistungsdifferenzen mittlere Leistungsdifferenzen sind.
18. Verfahren nach Anspruch 16, wobei der Berechnung der Phasendifferenz, der Kohärenzdaten oder des Leistungsverhältnisses eine grundsätzliche Komponentenanalyse (PCA) und/oder eine Zwischenkanalphasenausrichtung folgt, und zwar zum Erzeugen der Ausgangssignale.
19. Verfahren nach Anspruch 11, wobei wenigstens eines der in den N Kanälen transportierten Eingangssignale mit einem Effektekanal übereinstimmt.
20. Codierter Dateninhalt, erzeugt unter Anwendung des Verfahrens nach Anspruch 11.
21. Datenträger, auf dem codierte Daten nach Anspruch 20 gespeichert sind.
22. Decoder (800), vorgesehen zum Decodieren codierter Ausgangsdaten (370, 430, 450, 480, 490, 690), wie von einem Codierer (10; 600) nach Anspruch 1 codiert, wobei die genannten codierten Ausgangssignale (370, 430, 450, 480, 490, 690) M Kanäle (480, 590) und assoziierte parametrische Daten (370, 430, 450, 690), erzeugt aus Eingangssignalen von N Kanälen enthalten, so dass $M < N$ ist, wobei M und N ganze Zahlen sind, wobei der Decoder (800) einen Prozessor (810) enthält:

- (a) zum Empfangen der codierten Ausgangsdaten (370, 430, 450, 460, 490, 690) und zum Umwandeln derselben aus einer Zeitdomäne in eine Frequenzdomäne;
- (b) zum Anwenden der parametrischen Daten in der Frequenzdomäne zum Extrahieren von Inhalt aus den M Kanälen zum Regenerieren regenerierten Dateninhalts aus den M Kanälen entsprechend Eingangssignalen eines oder mehrerer der N Kanäle, die nicht unmittelbar in die codierten Ausgangssignale eingeschlossen oder aus denselben fortgelassen worden sind; und
- (c) zum Verarbeiten des regenerierten Dateninhalts zum Ausliefern eines oder mehrerer der regenerierten Eingangssignale von N Kanälen an einem oder mehreren Ausgängen des Decoders, **dadurch gekennzeichnet, dass** die parametrischen Daten wenigstens einen Parameter enthalten, der eine Leistung eines Zentralkanalsignals gegenüber einer Leistung eines Rechtskanalsignals und eines Linkskanalsignals für eine Zweikanalheruntermischung des Zentralkanalsignals, des Rechtskanalsignals und des Linkskanalsignals beschreibt; wobei der wenigstens eine Parameter gegeben wird durch:

$$IID_C = 10 \log_{10} \left(\frac{\epsilon^2 \sum_k C[k] C^*[k]}{\sum_k L[k] L^*[k] + \sum_k R[k] R^*[k]} \right)$$

wobei ein Symbol * eine konjugierte Zahl bezeichnet,
wobei $C[k]$ den Abtastwert k des Zentralkanalsignals C bezeichnet, wobei $R[k]$ den Abtastwert k des Rechtssignals R bezeichnet, wobei $L[k]$ den Abtastwert des Linkssignals L bezeichnet und wobei ϵ eine Gewichtung bezeichnet, die eine Stärke des Zentralsignals in der Zweikanalheruntermischung bezeichnet.

23. Decoder (800) nach Anspruch 22, wobei der genannte Prozessor (810) vorgesehen ist zum Anwenden eines Allpassdekorrelationsfilters zum Erhalten dekorrelierter Versionen von Signalen zur Verwendung bei der Regeneration des genannten einen Eingangssignals oder der genannten mehreren Eingangssignale von N Kanälen in dem Decoder.

5

24. Decoder (800) nach Anspruch 23, wobei der Prozessor wirksam ist zum Anwenden einer invertierten Codierrotation zum Spalten von Signalen der M Kanäle und dekorrelierten Versionen davon in ihre Basiskomponenten zum Regenerieren des genannten einen Signals oder der genannten mehreren Signale von N Kanälen in dem Decoder,

10 25. Decoder (800) nach Anspruch 24, wobei der genannte Decoder (800) wirksam ist zum Erzeugen seines einen Decoderausgangssignals oder von mehreren Ausgangssignalen (1300 bis 1340) nur aus den genannten codierten Ausgangsdaten (450, 480, 490), empfangen in dem Decoder (800).

15 **Revendications**

1. Codeur multi-canal (10; 600) agencé pour traiter de signaux d'entrée (300, 310, 320, 330, 340 ; 300, 310, 610, 620, 330, 340) transmis par N canaux d'entrée pour générer des signaux de sortie correspondants (480, 490) transmis par M canaux de sortie avec des données paramétriques (450) telles que M et N sont des entiers et que N est plus grand que M, le codeur comprenant :

20

(a) un mélangeur abaisseur afin de mélanger abaisser les signaux d'entrée pour générer les signaux de sortie correspondants, et

25

(b) un analyseur afin de traiter les signaux d'entrée soit pendant le mélange abaissement soit comme traitement séparé, ledit analyseur étant utilisable pour générer lesdites données paramétriques complémentaires aux signaux de sortie, lesdites données paramétriques décrivant des différences réciproques entre les N canaux de signal d'entrée afin de permettre substantiellement une régénération pendant le décodage d'un ou plus des N canaux du signal d'entrée à partir des M canaux de signal de sortie, lesdits signaux de sortie étant sous une forme compatible à la reproduction dans des décodeurs fournissant N canaux ou moins de N canaux de sortie de manière à assumer la compatibilité arrière, **caractérisé en ce que** les données paramétriques comprennent au moins un paramètre décrivant une puissance d'un signal de canal central relativement à une puissance d'un signal de canal droit et d'un signal de canal gauche pour un mélange abaissement à deux canaux du signal de canal central, du canal de signal droit et du canal de signal gauche; ledit au moins un paramètre étant donné par :

30

35

$$IID_c = 10 \log_{10} \left(\frac{\varepsilon^2 \sum_k C[k] C^*[k]}{\sum_k L[k] L^*[k] + \sum_k R[k] R^*[k]} \right),$$

40

où un symbole * indique un complexe conjugué,
où C[k] indique un échantillon k d'un signal de canal central C ; R[k] indique un échantillon k du signal droit R, L[k] indique un échantillon k du signal gauche L et ε indique un poids déterminant une force du signal central dans le mélange abaissement à deux canaux.

45

2. Codeur selon la revendication 1 dans lequel le codeur est un codeur à 5 canaux agencé pour générer les signaux de sortie et les données paramétriques sous une forme compatible avec au moins un des décodeurs stéréos à 2 canaux, décodeurs à 3 canaux et décodeurs à 4 canaux correspondants.

50

3. Codeur selon la revendication 1 dans lequel l'analyseur comprend un moyen de traitement pour convertir les signaux d'entrée au moyen d'une transformation d'un domaine temporel vers un domaine fréquentiel et pour traiter ces signaux d'entrée transformés pour générer les données paramétriques.

55

4. Codeur selon la revendication 3 dans lequel au moins l'un parmi le mélangeur abaisseur et l'analyseur sont agencés pour traiter les signaux d'entrée comme une séquence de pavages temps-fréquence pour générer les signaux de sortie.

5. Codeur selon la revendication 4 dans lequel les pavages sont obtenus par transformation de fenêtres d'analyse se

chevauchant mutuellement.

6. Codeur selon la revendication 1, comprenant un codeur pour traiter les signaux d'entrée pour générer M canaux de données audio intermédiaires pour inclusion dans les M signaux de sortie, l'analyseur étant agencé pour produire des informations de sortie dans les données paramétriques concernant au moins un point parmi les suivants :

- (a) les rapports de puissance de signal d'entrée inter-canal ou les différences logarithmiques de niveau;
- (b) la cohérence inter-canal entre les signaux d'entrée ;
- (c) un rapport de puissance entre les signaux d'entrée d'un ou de plusieurs canaux et une somme des puissances des signaux d'entrée d'un ou de plusieurs canaux; et
- (d) les différences de phase ou les différences temporelle entre paires de signaux.

7. Codeur selon la revendication 6 dans lequel lesdites différences de phase en (d) sont des différences de phase moyennes.

8. Codeur selon la revendication 6 dans lequel le calcul de ladite au moins une parmi les différences de phase, la donnée de cohérence et les rapports de puissance est suivi par une analyse en composante principale (ACP - PCA principal component analysis) et/ou un alignement de phase inter-canal pour générer les N signaux de sortie.

9. Codeur selon la revendication 1, dans lequel au moins un des signaux d'entrée transmis dans les N canaux correspondant à un canal d'effets.

10. Codeur selon la revendication 1 agencé pour générer les signaux de sortie sous une forme adaptée à la reproduction en utilisant des systèmes de reproduction conventionnels.

11. Procédé de codage de signaux d'entrée transmis par N canaux d'entrée dans un codeur multi-canal pour générer des signaux de sortie correspondants transmis par M canaux de sortie avec des données paramétriques telles que M et N sont des entiers et que N est plus grand que M, le procédé comprenant les étapes de :

- (a) mélange-abaissement des signaux d'entrée pour générer les signaux de sortie correspondants, et
- (b) traitement des signaux d'entrée dans un analyseur pendant le mélange abaissement ou séparément, ledit traitement fournissant lesdites données paramétriques complémentaires aux signaux de sortie, lesdites données paramétriques décrivant des différences réciproques entre les N canaux de signal d'entrée afin de permettre substantiellement une régénération pendant le décodage d'un ou plus des N canaux du signal d'entrée à partir des M canaux de signal de sortie, lesdits signaux de sortie étant sous une forme compatible à la reproduction dans des décodeurs fournissant N canaux ou moins de N canaux, **caractérisé en ce que** les données paramétriques comprennent au moins un paramètre décrivant une puissance d'un signal de canal central relativement à une puissance d'un signal de canal droit et d'un signal de canal gauche pour un mélange abaissement à deux canaux du signal de canal central, du canal de signal droit et du canal de signal gauche; ledit au moins un paramètre étant donné par :

$$IID_c = 10 \log_{10} \left(\frac{\varepsilon^2 \sum_k C[k]C^*[k]}{\sum_k L[k]L^*[k] + \sum_k R[k]R^*[k]} \right),$$

où un symbole * indique un complexe conjugué,

où C[k] indique un échantillon k d'un signal de canal central C; R[k] indique un échantillon k du signal droit R, L[k] indique un échantillon k du signal gauche L et ε indique un poids déterminant une force du signal central dans le mélange abaissement à deux canaux.

12. Procédé selon la revendication 11 agencé pour coder des signaux d'entrée correspondant à 5 canaux et générer les signaux de sortie et les données paramétriques sous une forme compatible avec un ou plusieurs des décodeurs stéréos à 2 canaux, décodeurs à 3 canaux et décodeurs à 4 canaux correspondants.

13. Procédé selon la revendication 11 dans lequel ledit traitement comprend une conversion des signaux d'entrée au

EP 1 735 774 B1

moyen d'une transformation d'un domaine temporel vers un domaine fréquentiel.

14. Procédé selon la revendication 13 dans lequel au moins un des signaux d'entrée est traité comme une séquence de pavages temps-fréquence pour générer les signaux de sortie.

15. Procédé selon la revendication 14 dans lequel les pavages correspondent à des fenêtres d'analyse se chevauchant mutuellement.

16. Procédé selon la revendication 11, le procédé comprenant une étape utilisant un codeur pour traiter les signaux d'entrée pour générer M canaux de données audio intermédiaires pour inclusion dans les signaux de sortie, le codeur étant agencé pour produire des informations dans les données paramétriques concernant au moins un point parmi les suivants :

(a) les rapports de puissance d'entrée inter-canal ou les différences logarithmiques de niveau;

(b) la cohérence inter-canal entre les signaux d'entrée ;

(c) un rapport de puissance entre les signaux d'entrée d'un ou de plusieurs canaux et une somme des puissances des signaux d'entrée d'un ou de plusieurs canaux; et

(d) les différences de puissance ou les différences temporelle entre paires de signaux.

17. Procédé selon la revendication 16 dans lequel lesdites différences de puissance sont des différences de puissance moyennes.

18. Procédé selon la revendication 16 dans lequel le calcul de ladite au moins une parmi la différence de phase, la donnée de cohérence et les rapports de puissance est suivi par une analyse en composante principale (ACP - PCA principal component analysis) et/ou un alignement de phase inter-canal pour générer les signaux de sortie.

19. Procédé selon la revendication 11, dans lequel au moins un des signaux d'entrée transmis dans les N canaux correspond à un canal d'effets.

20. Contenu de données codées qui sont générées en utilisant le procédé de la revendication 11.

21. Support de données sur lequel sont stockées des données codées comme revendiqué à la revendication 20.

22. Décodeur (800) utilisable pour décoder des données de sorties codées (370, 430, 450, 480, 490, 690) telles que générées par un codeur (10, 600) selon la revendication 1, lesdites données de sortie codées (370, 430, 450, 480, 490, 690) comprenant M canaux (480, 490) et des données paramétriques associées (370, 430, 450, 690) générées à partir des signaux d'entrées de N canaux tels que $M < N$ où M et N sont des entiers, le décodeur (800) comprenant un processeur (810) :

(a) pour recevoir les données de sortie codées (370, 430, 450, 460, 490, 690) et les convertir d'un domaine temporel vers domaine fréquentiel ;

(b) pour appliquer les données paramétriques dans le domaine fréquentiel et extraire un contenu à partir des M canaux pour régénérer à partir des M canaux un contenu de données régénérées correspondant aux signaux d'entrée d'un ou de plusieurs des N canaux pas directement inclus ou omis dans les données de sortie codées, et

(c) pour traiter le contenu des données régénérées et produire à une ou plusieurs sorties du décodeur un ou plusieurs des signaux d'entrée régénérés des N canaux, **caractérisé en ce que** les données paramétriques comprennent au moins un paramètre décrivant une puissance d'un signal de canal central relativement à une puissance d'un signal de canal droit et d'un signal de canal gauche pour un mélange abaissement à deux canaux du signal de canal central, du canal de signal droit et du canal de signal gauche; ledit au moins un paramètre étant donné par :

$$IID_c = 10 \log_{10} \left(\frac{\varepsilon^2 \sum_k C[k] C^*[k]}{\sum_k L[k] L^*[k] + \sum_k R[k] R^*[k]} \right),$$

EP 1 735 774 B1

où un symbole * indique un complexe conjugué,

où $C[k]$ indique un échantillon k d'un signal de canal central C ; $R[k]$ indique un échantillon k du signal droit R , $L[k]$ indique un échantillon k du signal gauche L et ε indique un poids déterminant une force du signal central dans le mélange abaissé à deux canaux.

- 5
- 23.** Décodeur (800) selon la revendication 22 dans lequel le dit processeur (810) est utilisable pour appliquer un filtre de décorrélation passe-tout pour obtenir des versions décorrélées des signaux à utiliser dans la régénération au décodeur desdits un ou plusieurs signaux d'entrée des N canaux.
- 10
- 24.** Décodeur (800) selon la revendication 23 dans lequel ledit processeur est utilisable pour appliquer une rotation inverse à celle de l'encodeur pour décomposer les signaux des M canaux et les versions décorrélées de ceux-ci en leurs composantes constitutives afin de régénérer au décodeur lesdits un ou plusieurs signaux d'entrée des N canaux.
- 15
- 25.** Décodeur (800) selon la revendication 24 dans lequel ledit décodeur (800) est utilisable pour générer ses une ou plusieurs sorties de décodeur (1300 à 1340) uniquement à partir desdites données de sortie codées (450, 480, 490) reçues au décodeur (800).

20

25

30

35

40

45

50

55

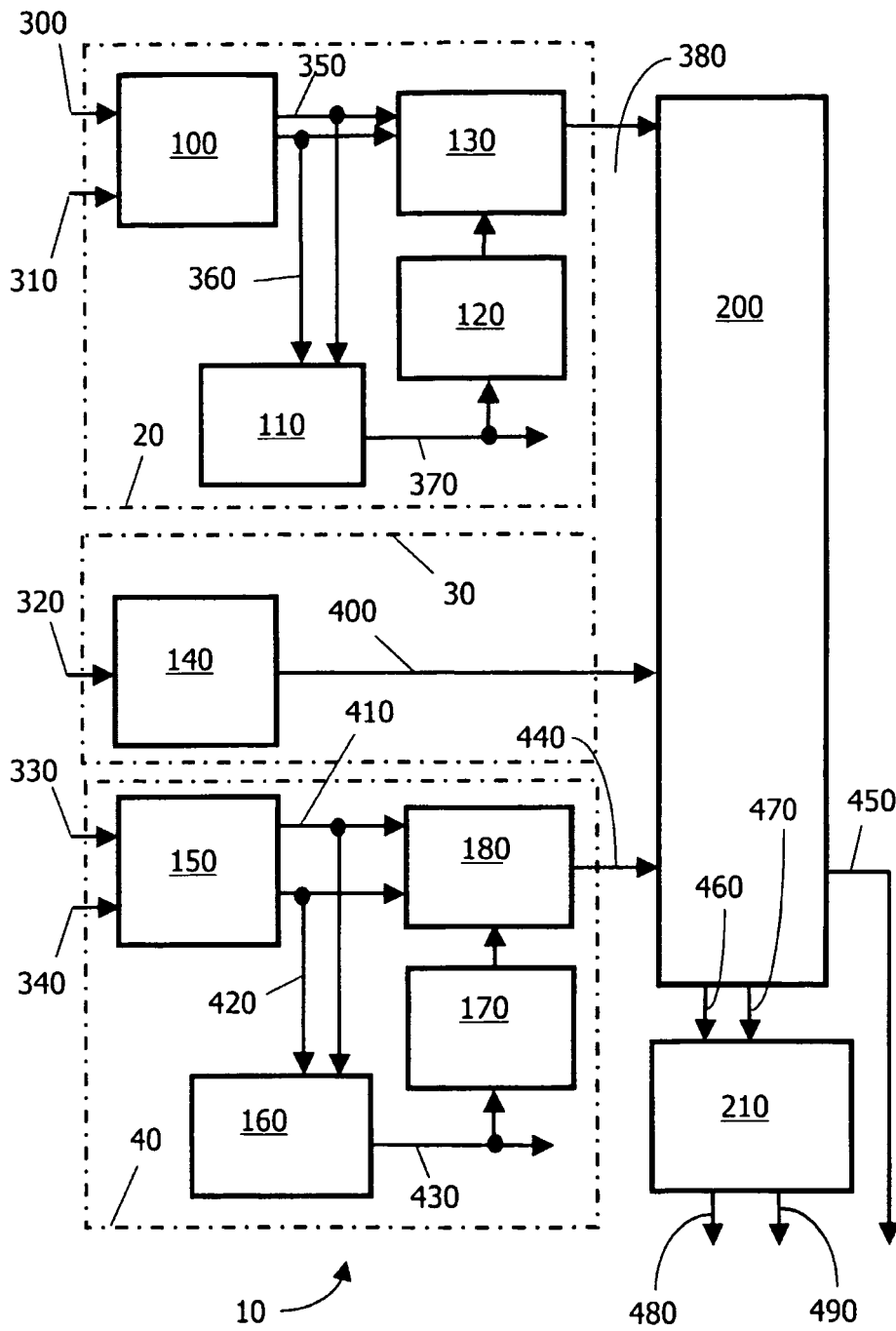

FIG. 1

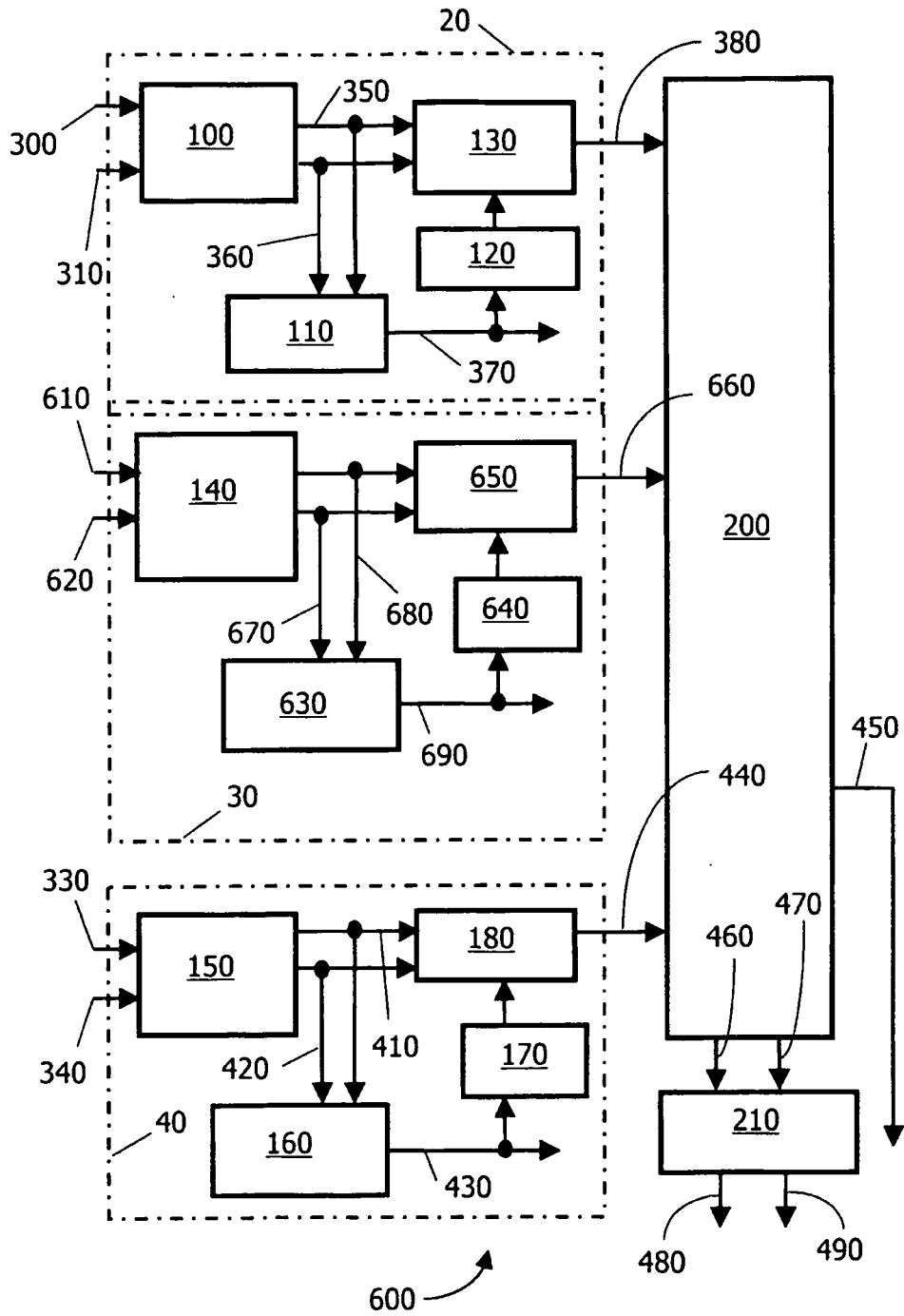

FIG.2

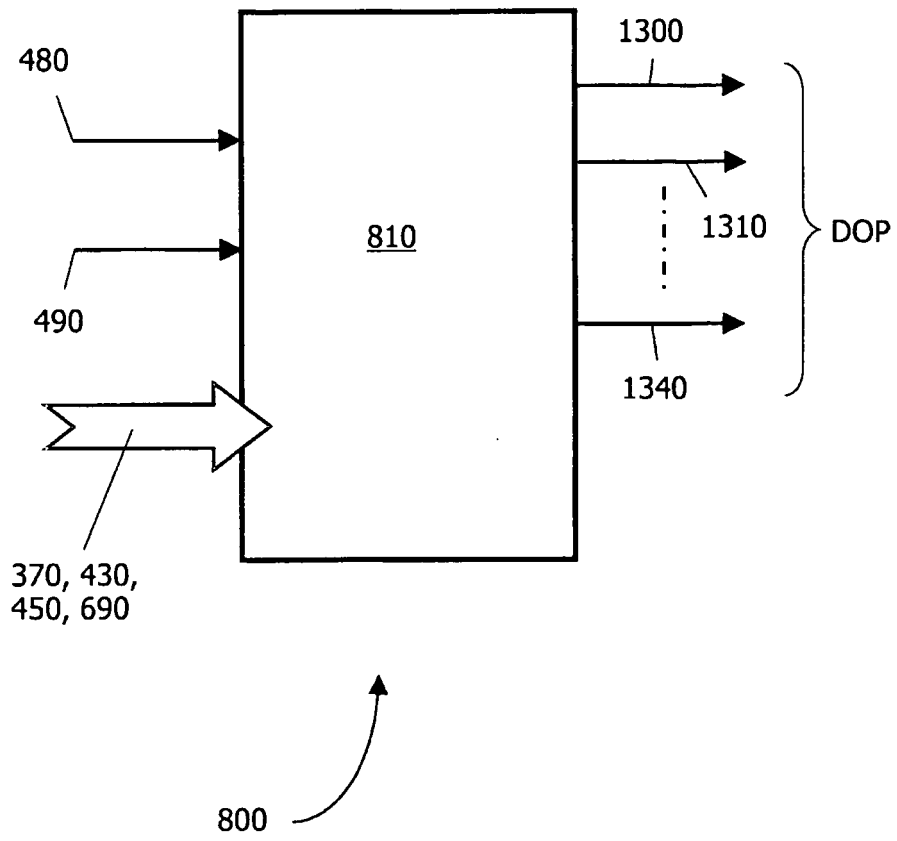

FIG.3

REFERENCES CITED IN THE DESCRIPTION

This list of references cited by the applicant is for the reader's convenience only. It does not form part of the European patent document. Even though great care has been taken in compiling the references, errors or omissions cannot be excluded and the EPO disclaims all liability in this regard.

Patent documents cited in the description

- US 2003002858 W [0004]
- WO 2004008805 A [0004]

Non-patent literature cited in the description

- **FALLER C et al.** Binaural Cue Coding: A Novel and Efficient Representation of Spatial Audio. *Audio Engineering Society Convention Paper*, 10 May 2002, 1841-1844 [0003]