

(19)



(11)

**EP 1 671 316 B1**

(12)

**EUROPEAN PATENT SPECIFICATION**

(45) Date of publication and mention of the grant of the patent:  
**01.08.2007 Bulletin 2007/31**

(51) Int Cl.:  
**G10L 19/00 (2006.01)**

(21) Application number: **04770014.1**

(86) International application number:  
**PCT/IB2004/051775**

(22) Date of filing: **16.09.2004**

(87) International publication number:  
**WO 2005/031704 (07.04.2005 Gazette 2005/14)**

(54) **ENCODING AUDIO SIGNALS**

CODIERUNG VON AUDIOSIGNALEN

CODAGE DE SIGNAUX AUDIO

(84) Designated Contracting States:  
**AT BE BG CH CY CZ DE DK EE ES FI FR GB GR HU IE IT LI LU MC NL PL PT RO SE SI SK TR**

(56) References cited:  
**US-A1- 2003 026 441**

(30) Priority: **29.09.2003 EP 03103591**

- **BREEBAART J ET AL: "High-quality parametric spatial audio coding at low bitrates" PREPRINTS OF PAPERS PRESENTED AT THE 116TH AES CONVENTION, 8 May 2004 (2004-05-08), pages 1-13, XP009042418 BERLIN**

(43) Date of publication of application:  
**21.06.2006 Bulletin 2006/25**

- **SCHUIJERS E ET AL: "ADVANCES IN PARAMETRIC CODING FOR HIGH-QUALITY AUDIO" PREPRINTS OF PAPERS PRESENTED AT THE 114TH AES CONVENTION, 22 March 2003 (2003-03-22), pages 1-11, XP008021606 AMSTERDAM**

(73) Proprietor: **Koninklijke Philips Electronics N.V. 5621 BA Eindhoven (NL)**

(72) Inventor: **BREEBAART, Dirk, J. NL-5656 AA Eindhoven (NL)**

(74) Representative: **van der Veer, Johannis Leendert et al  
Philips  
Intellectual Property & Standards  
P.O. Box 220  
5600 AE Eindhoven (NL)**

**EP 1 671 316 B1**

Note: Within nine months from the publication of the mention of the grant of the European patent, any person may give notice to the European Patent Office of opposition to the European patent granted. Notice of opposition shall be filed in a written reasoned statement. It shall not be deemed to have been filed until the opposition fee has been paid. (Art. 99(1) European Patent Convention).

**Description**

FIELD OF THE INVENTION

5 **[0001]** The invention relates to an encoder for audio signals, and a method of encoding audio signals.

BACKGROUND OF THE INVENTION

10 **[0002]** Within the field of audio coding it is generally desired to encode an audio signal in order to reduce the bit rate without unduly compromising the perceptual quality of the audio signal. The reduced bit rate is advantageous for limiting the bandwidth when communicating the audio signal or the amount of storage required for storing the audio signal.

**[0003]** Parametric descriptions of audio signals have gained interest during the last years, especially in the field of audio coding. It has been shown that transmitting (quantized) parameters which describe audio signals require only a limited transmission capacity to enable to synthesize perceptually substantially equal audio signals at the receiving end.

15 **[0004]** US2003/0026441 discloses the synthesizing of an auditory scene by applying two or more different sets of one or more spatial parameters (e.g. an inter-ear level difference ILD, or an inter-ear time difference ITD) to two or more different frequency bands of a combined audio signal, wherein each different frequency band is treated as if it corresponds to a single audio source in the auditory scene. In one embodiment, the combined audio signal corresponds to the combination of the left and right audio signals of a binaural signal corresponding to an input auditory scene. The different sets of spatial parameters are applied to reconstruct the input auditory scene. The transmission bandwidth requirements are reduced by reducing to one the number of different audio signals that need to be transmitted to a receiver configured to synthesize/reconstruct the auditory scene.

20 **[0005]** In the transmitter, a TF transform is applied to corresponding parts of each of the left and right audio signals of the input binaural signal to convert the signals to the frequency domain. An auditory scene analyzer processes the converted left and right audio signals in the frequency domain to generate a set of auditory scene parameters for each one of a plurality of different frequency bands in those converted signals. For each corresponding pair of frequency bands, the analyzer compares the converted left and right audio signals to generate one or more spatial parameters. In particular, for each frequency band, the cross-correlation function between the converted left and right audio signals is estimated. The maximum value of the cross-correlation indicates how much the two signals are correlated. The location in time of the maximum of the cross-correlation corresponds to the ITD. The ILD can be obtained by computing the level difference of the power values of the left and right audio signals.

SUMMARY OF THE INVENTION

35 **[0006]** It is an object of the invention to provide an encoder for encoding audio signals which requires less processing power.

**[0007]** To reach this object, a first aspect of the invention provides an encoder for encoding audio signals. A second aspect of the invention provides a method of encoding audio signals. Advantageous embodiments are defined in the dependent claims.

40 **[0008]** The encoder disclosed in US2003/0026441 first transforms the audio signals from the time domain to the frequency domain. This transformation is usually referred to as the Fast Fourier Transform, further referred to as FFT. Usually, the audio signal in the time domain is divided into a sequence of time segments or frames, and the transformation to the frequency domain is performed sequentially for each one of the frames. The relevant part of the frequency domain is divided into frequency bands. In each frequency band the cross-correlation function is determined of the input audio signals. This cross-correlation function has to be transformed from the frequency domain to the time domain. This transformation is usually referred to as the inverse FFT further referred to as IFFT. In the time domain, the maximum value of the cross-correlation function has to be determined to find the location in time of this maximum and thus the value of the ITD.

45 **[0009]** The encoder in accordance with the first aspect of the invention also has to transform the audio signals from the time domain to the frequency domain, and also has to determine the cross-correlation function in the frequency domain. In the encoder in accordance with the invention, the spatial parameter used is the inter-channel phase difference further referred to as IPD or the inter-channel coherence further referred to as IC, or both. Also other spatial parameters such as the inter-channel level differences further referred to as ILD may be coded. The inter-channel phase difference IPD is comparable with the inter-ear time difference ITD of the prior art.

50 **[0010]** However instead of performing the IFFT and the search for the maximum value of the cross-correlation function in the time domain, a complex coherence value is calculated by summing the (complex) cross-correlation function values in the frequency domain. The inter-channel phase difference IPD is estimated by the argument of the complex coherence value, the inter-channel coherence IC is estimated by the absolute value of the complex coherence value.

**[0011]** In the prior art US2003/0026441, the inverse FFT and the search for the maximum of the cross-correlation function in the time domain requires a high amount of processing effort. This prior art is silent about the determination of the coherence parameter.

**[0012]** In the encoder in accordance with the invention the inverse FFT is not required, the complex coherence value is calculated by summing the (complex) cross-correlation function values in the frequency domain. Either the IPD or the IC, or the IPD and the IC are determined in a simple manner from this sum. Thus, the high computational effort for the inverse FFT is replaced by a simple summing operation. Consequently, the approach in accordance with the invention requires less computational effort.

**[0013]** It should be noted that although prior art US2003/0026441 uses an FFT to yield a complex-valued frequency-domain representation of the input signals, complex filter banks may also be used. Such filter banks use complex modulators to obtain a set of band-limited complex signals (cf. Ekstrand, P. (2002). Bandwidth extension of audio signals by spectral band replication. Proc. 1<sup>st</sup> Benelux Workshop on model based processing and coding of audio (MPCA-2002), Leuven, Belgium). The IPD and IC parameters can be computed in a similar way as for the FFT, with the only difference that summation is required across time instead of frequency bin.

**[0014]** The frequency domain is divided into a predetermined number of frequency sub-bands, further also referred to as sub-bands. The frequency range covered by different sub-bands may increase with the frequency. The complex cross-correlation function is determined for each sub-band, by using both the input audio signals in the frequency domain in this sub-band. The input audio signals in the frequency domain in a particular one of the sub-bands are also referred to as sub-band audio signals. The result is a cross-correlation function for each one of the sub-bands. Alternatively, the cross-correlation function may only be determined for a sub-set of the sub-bands, depending on the required quality of the synthesized audio signals. The complex coherence value is calculated by summing the (complex) cross-correlation function values in each of the sub-bands. And thus, also the IPD and/or IC are determined per sub-band. This sub-band approach enables to provide a different coding for different frequency sub-bands and allows to further optimize the quality of the decoded audio signal versus the bit-rate of the coded audio signal.

**[0015]** In an embodiment the cross-correlation function is calculated as a multiplication of one of the input audio signals in a band-limited, complex domain and the complex conjugated other one of the input audio signals to obtain a complex cross-correlation function which can be thought to be represented by an absolute value and an argument.

**[0016]** In an embodiment a corrected cross-correlation function is calculated as the cross-correlation function wherein the argument is replaced by the derivative of said argument. At high frequencies, it is known that the human auditory system is not sensitive to fine-structure phase-differences between the two input channels. However, considerable sensitivity to the time difference and coherence of the envelope exists. Hence at high frequencies, it is more relevant to compute the envelope ITD and envelope coherence for each frequency band. However, this requires an additional step of computing the (Hilbert) envelope. In the embodiment in accordance with the invention as defined in claim 3, it is possible to calculate the complex coherence value by summing the corrected cross-correlation function directly in the frequency domain. Again, the IPD and/or IC can be determined in a simple manner from this sum as the argument and phase of the sum, respectively.

**[0017]** In an embodiment for lower frequencies, the complex cross-correlation functions per sub-band are obtained by multiplying one of the sub-band audio signals with the complex conjugated other one of the sub-band audio signals. The complex cross-correlation function has an absolute value and an argument. The complex coherence value is obtained by summing the values of the cross-correlation function in each of the sub-bands. For higher frequencies, corrected cross-correlation functions are determined which are determined in the same manner as the cross-correlation functions for lower frequencies but wherein the argument is replaced by a derivative of this argument. Now, the complex coherence value per sub-band is obtained by summing the values of the corrected cross-correlation function per sub-band. The IPD and/or IC are determined in the same manner from the complex coherence value, independent on the frequency.

**[0018]** These and other aspects of the invention are apparent from and will be elucidated with reference to the embodiments described hereinafter.

#### BRIEF DESCRIPTION OF THE DRAWINGS

**[0019]** In the drawings:

Fig. 1 shows a block diagram of an audio encoder,

Fig. 2 shows a block diagram of an audio encoder of an embodiment in accordance with the invention,

Fig. 3 shows a block diagram of part of the audio encoder of another embodiment in accordance with the invention, and

Fig. 4 shows a schematic representation of the sub-band division of the audio signals in the frequency domain.

## DETAILED DESCRIPTION OF THE PREFERRED EMBODIMENT

**[0020]** Fig. 1 shows a block diagram of an audio encoder. The audio encoder receives two input audio signals  $x(n)$  and  $y(n)$  which are digitized representations of, for example, the left audio signal and the right audio signal of a stereo signal in the time domain. The indices  $n$  refer to the samples of the input audio signals  $x(n)$  and  $y(n)$ . The combining circuit 1 combines these two input audio signals  $x(n)$  and  $y(n)$  into a monaural signal MAS. The stereo information in the input audio signals  $x(n)$  and  $y(n)$  is parameterized in the parameterizing circuit 10 which comprises the circuits 100 to 113 and supplies, by way of example only, the parameters ITDi, the inter-channel time difference per frequency sub-band (or the IPDi: inter-channel phase difference per frequency sub-band) and C<sub>li</sub> (inter-channel coherence per frequency sub-band). The monaural signal MAS and the parameters ITDi, IC<sub>i</sub> are transmitted in a transmission system or stored on a storage medium (not shown). At the receiver or decoder (not shown) the original signals  $x(n)$  and  $y(n)$  are reconstructed from the monaural signal MAS and the parameters ITDi, IC<sub>i</sub>.

**[0021]** Usually, the input audio signals  $x(n)$  and  $y(n)$  are processed per time segment or frame. The segmentation circuit 100 receives the input audio signal  $x(n)$  and stores the received samples during a frame to be able to supply the stored samples  $S_x(n)$  of the frame to the FFT-circuit 102. The segmentation circuit 101 receives the input audio signal  $y(n)$  and stores the received samples during a frame to be able to supply the stored samples  $S_y(n)$  of the frame to the FFT-circuit 103.

**[0022]** The FFT-circuit 102 performs a Fast Fourier Transformation on the stored samples  $S_x(n)$  to obtain an audio signal  $X(k)$  in the frequency domain. In the same manner, the FFT-circuit 103 performs a Fast Fourier Transformation on the stored samples  $S_y(n)$  to obtain an audio signal  $Y(k)$  in the frequency domain. The sub-band dividers 104 and 105 receive the audio signals  $X(k)$  and  $Y(k)$ , respectively, to divide the frequency spectra of these audio signals  $X(k)$  and  $Y(k)$  into frequency sub-bands  $i$  (see Fig. 4) to obtain the sub-band audio signals  $X_i(k)$  and  $Y_i(k)$ . This operation is further elucidated with respect to Fig. 4.

**[0023]** The cross-correlation determining circuit 106 calculates the complex cross-correlation function  $R_i$  of the sub-band audio signals  $X_i(k)$  and  $Y_i(k)$  for each relevant subband. Usually, the cross-correlation function  $R_i$  is obtained in each relevant sub-band by multiplying one of the audio signals in the frequency domain  $X_i(k)$  with the complex conjugated other one of the audio signals in the frequency domain  $Y_i(k)$ . It would be more correct to indicate the cross-correlation function with  $R_i(X, Y)(k)$  or  $R_i(X(k), Y(k))$ , but for clarity this is abbreviated to  $R_i$ .

**[0024]** The optional normalizing circuit 107 normalizes the cross-correlation function  $R_i$  to obtain a normalized cross-correlation function  $P_i(X, Y)(k)$  or  $P_i(X(k), Y(k))$  which is abbreviated to  $P_i$ :

$$P_i = R_i(X_i, Y_i) / \text{sqrt}(\text{sum}(X_i(k) \cdot \text{conj } X_i(k)) * (\text{sum } X_i(k) \cdot \text{conj } X_i(k)))$$

wherein sqrt is the square root, and conj is the complex conjugation.

It is to be noted that this normalization process requires the computation of the energies of the sub-band signals  $X_i(k)$ ,  $Y_i(k)$  of the two input signals  $x(n)$ ,  $y(n)$ . However, this operation is required anyway in order to compute the inter-channel intensity difference IID for the current sub-band  $i$ . The IID is determined by the quotient of these energies. Thus, the cross function  $R_i$  can be normalized by taking the goniometric mean of the corresponding sub-band intensities of the two input signals  $X_i(k)$ ,  $Y_i(k)$ .

**[0025]** The known IFFT (Inverse Fast Fourier Transform) circuit 108 transforms the normalized cross-correlation function  $P_i$  in the frequency domain back to the time domain, yielding the normalized cross-correlation  $r_i(x(n), y(n))$  or  $r_i(x, y)(n)$  in the time domain which is abbreviated as  $r_i$ . The circuit 109 determines the peak value of the normalized cross-correlation  $r_i$ . The inter-channel time delay ITDi for a particular sub-band is the argument  $n$  of the normalized cross-correlation  $r_i$  at which the peak value occurs. Or said in other words, the delay which corresponds to this maximum in the normalized cross-correlation  $r_i$  is the ITDi. The inter-channel coherence IC<sub>i</sub> for the particular sub-band is the peak value. The ITDi provides the required shift of the two input audio signals  $x(n)$ ,  $y(n)$  with respect to each other to obtain the highest possible similarity. The IC<sub>i</sub> indicates how similar the shifted input audio signals  $x(n)$ ,  $y(n)$  are in each sub-band. Alternatively, the IFFT may be performed on the not normalized cross-correlation function  $R_i$ .

**[0026]** Although this block diagram shows separate blocks performing operations, the operations may be performed by a single dedicated circuit or integrated circuit. It is also possible to perform all the operations or a part of the operations by a suitably programmed microprocessor.

**[0027]** Fig. 2 shows a block diagram of an audio encoder of an embodiment in accordance with the invention. This audio encoder comprises the same circuits 1, and 100 to 107 as shown in Fig. 1 which operate in the same manner. Again, the optional normalizing circuit 107 normalizes the cross-correlation function  $R_i$  to obtain a normalized cross-correlation function  $P_i$ . The coherence value computing circuit 111 computes a complex coherence value  $Q_i$  for each relevant sub-band  $i$  by summing the complex normalized cross-correlation function  $P_i$ :

$$Q_i = \text{sum} (P_i(X_i(k), Y_i(k)))$$

5 The FFT-bin index  $k$  is determined by the bandwidth of each sub-band. Preferably, to minimize computation efforts, only the positive ( $k = 0$  to  $K/2$ , where  $K$  is the FFT size) or negative frequencies ( $k = -K/2$  to  $0$ ) are summed. This computation is performed in the frequency domain and thus does not require an IFFT to first transform the normalized cross-correlation function  $P_i$  to the time domain. The coherence estimator 112 estimates the coherence  $IC_i$  with the absolute value of the complex coherence value  $Q_i$ . The phase difference estimator 113 estimates the IPD $_i$  with the argument or angle of the complex coherence value  $Q_i$ .

10 **[0028]** Thus now, the inter-channel coherence  $IC_i$  and the inter-channel phase difference IPD $_i$  are obtained for each relevant sub-band  $i$  without requiring, in each relevant sub-band, an IFFT operation and a search for the maximum value of the normalized cross-correlation  $r_i$ . This saves a considerable amount of processing power. Alternatively, the complex coherence value  $Q_i$  may be obtained by summing the not normalized cross-correlation function  $R_i$ .

15 **[0029]** Fig. 3 shows a block diagram of part of the audio encoder of another embodiment in accordance with the invention.

**[0030]** For high frequencies, for example above 2 kHz or above 4 kHz, in the prior art (cf. Baumgarte, F., Faller, C (2002). Estimation of auditory spatial cues for binaural cue coding. Proc. ICASSP'02), the envelope coherence may be calculated which is even more computational intensive than computing the waveform coherence as elucidated with respect to Fig. 1. Experimental results demonstrated that the envelope coherence can be fairly accurately estimated by replacing the phase values ARG of the frequency domain (normalized) complex cross-correlation function  $R_i$  by the derivative DA of these phase values ARG.

20 **[0031]** Fig. 3 shows the same cross-correlation determining circuit 106 as in Fig. 1. The cross-correlation determining circuit 106 calculates the complex cross-correlation function  $R_i$  of the sub-band audio signals  $X_i(k)$  and  $Y_i(k)$  for each relevant sub-band. Usually, the cross-correlation function  $R_i$  is obtained in each relevant sub-band by multiplying one of the audio signals in the frequency domain  $X_i(k)$  with the complex conjugated other one of the audio signals in the frequency domain  $Y_i(k)$ . The circuit 114 which receives the cross-correlation function  $R_i$  comprises a calculation unit 1140 which determines the derivative DA of the argument ARG of this complex cross-correlation function  $R_i$ . The amplitude AV of the cross-correlation function  $R_i$  is unchanged. The output signal of the circuit 114 is a corrected cross-correlation function  $R'_i(X_i(k), Y_i(k))$  (which is also referred to as  $R'_i$ ) which has the amplitude AV of the cross-correlation function  $R_i$  and an argument which is the derivative DA of the argument ARG:

$$35 \quad | R'_i(X_i(k), Y_i(k)) | = | R_i(X_i(k), Y_i(k)) |$$

and

$$40 \quad \arg(R'_i(X_i(k), Y_i(k))) = d(\arg(R_i(X_i(k), Y_i(k))))/dk$$

45 The coherence value computing circuit 11 computes a complex coherence value  $Q_i$  for each relevant sub-band  $i$  by summing the complex cross-correlation function  $R'_i$ . Thus, instead of the computational intensive Hilbert envelope approach now only simple operations are required.

**[0032]** The above described approach can of course also be applied on the normalized complex cross-correlation function  $P_i$  to obtain a corrected complex normalized cross-correlation function  $P'_i$ .

50 **[0033]** Fig. 4 shows a schematic representation of the sub-band division of the audio signals in the frequency domain. Fig. 4A shows how the audio signal  $X(k)$  in the frequency domain is divided into sub-band audio signals  $X_i(k)$  in sub-bands  $i$  of the frequency spectrum  $f$ . Fig. 4B shows how the audio signal  $Y(k)$  in the frequency domain is divided into sub-band audio signals  $Y_i(k)$  in sub-bands  $i$  of the frequency spectrum  $f$ . The frequency-domain signals  $X(k)$  and  $Y(k)$  are grouped into sub-bands  $i$ , resulting in sub-bands  $X_i(k)$  and  $Y_i(k)$ . Each sub-band  $X_i(k)$  corresponds to a certain range of FFT-bin indexes  $k=[k_{si}...k_{ei}]$ , where  $k_{si}$  and  $k_{ei}$  indicate the first and last FFT bin index  $k$ , respectively. Similarly each subband  $Y_i(k)$  corresponds to the same range of FFT-bin indexes  $k$ .

55 **[0034]** It should be noted that the above-mentioned embodiments illustrate rather than limit the invention, and that those skilled in the art will be able to design many alternative embodiments without departing from the scope of the

appended claims.

**[0035]** The invention is not limited to stereo signals and may, for example, be implemented on multi-channel audio as used in DVD and SACD.

**[0036]** In the claims, any reference signs placed between parentheses shall not be construed as limiting the claim. Use of the verb "comprise" and its conjugations does not exclude the presence of elements or steps other than those stated in a claim. The article "a" or "an" preceding an element does not exclude the presence of a plurality of such elements. The invention may be implemented by means of hardware comprising several distinct elements, and by means of a suitably programmed computer. In the device claim enumerating several means, several of these means may be embodied by one and the same item of hardware. The mere fact that certain measures are recited in mutually different dependent claims does not indicate that a combination of these measures cannot be used to advantage.

## Claims

1. An encoder for encoding audio signals, the encoder comprising:

- means (1) for generating a monaural signal (MAS) comprising a combination of at least two input audio signals  $(x(n), y(n))$ , and
- means (10) for generating a set of spatial parameters (IPDi; ICi) indicative of spatial properties of the at least two input audio signals  $(x(n), y(n))$ , wherein the set of spatial parameters (IPDi; ICi) at least comprises an inter-channel coherence value (ICi) and/or an inter-channel phase difference value (IPDi), wherein the means (10) for generating the set of spatial parameters (IPDi; ICi) comprises
  - means (102, 103) for transforming the input audio signals  $(x(n), y(n))$  into a frequency domain to obtain audio signals in the frequency domain  $(X(k), Y(k))$ ,
  - means (104, 105) for dividing the audio signals in the frequency domain  $(X(k), Y(k))$  into corresponding pluralities of sub-band signals  $(Xi(k), Yi(k))$  associated with frequency sub-bands (i), **characterized by**
  - means (106, 107) for generating a cross-correlation function  $(Ri; Pi)$  for each of the at least two input audio signals  $(x(n), y(n))$  from the sub-band signals  $(Xi(k), Yi(k))$  for at least one of the frequency sub-bands (i) belonging to a subset of the frequency sub-bands (i),
  - means (111) for determining a complex coherence value  $(Qi)$  by summing values of the cross-correlation function  $(Ri; Pi)$  in each one of the frequency sub-bands (i) of the subset, and
  - means (112) for determining an absolute value of the complex coherence value  $(Qi)$  to obtain an estimate of the inter-channel coherence value (ICi) in each one of the frequency sub-bands (i) of the subset, and/or
  - means (113) for determining an argument of the complex coherence value  $(Qi)$  to obtain an estimate of the inter-channel phase difference value (IPDi) in each one of the frequency sub-bands (i) of the subset.

2. An encoder for encoding audio signals as claimed in claim 1, wherein the means (106, 107) for generating a cross-correlation function  $(Ri; Pi)$  are arranged for calculating a complex cross-correlation function  $(Ri, Pi)$  as a multiplication of one of the sub-band signals in the frequency domain  $(Xi(k))$  with the complex conjugated other one of the sub-band signals in the frequency domain  $(Yi(k))$ .

3. An encoder for encoding audio signals as claimed in claim 2, wherein the means (106, 107) for generating the cross-correlation function  $(Ri; Pi)$  are arranged for calculating a corrected cross-correlation function  $(R'i)$  being the cross-correlation function  $(Ri)$  wherein its argument (ARG) is replaced by a derivative (DA) of said argument (ARG), and wherein the means (111) for determining the complex coherence value  $(Qi)$  is arranged for summing the values of the corrected cross-correlation function  $(R'i)$ .

4. An encoder for encoding audio signals as claimed in claim 1, wherein the means (106, 107) for generating the cross-correlation function  $(Ri; Pi)$  are arranged for calculating for frequency sub-bands (i) below a predetermined frequency, the cross-correlation function  $(Ri; Pi)$  as a multiplication of one of the sub-band signals in the frequency domain  $(Xi(k))$  and the complex conjugated other one of the sub-band signals in the frequency domain  $(Yi(k))$ , wherein the means (111) for determining the complex coherence value  $(Qi)$  is arranged for summing the values of the cross-correlation function  $(Ri; Pi)$  in each one of the frequency sub-bands (i) of the subset, and for frequency sub-bands (i) above the predetermined frequency, corrected cross-correlation functions  $(R'i)$  being the cross-correlation function  $(Ri)$  wherein its argument (ARG) is replaced by a derivative (DA) of said argument (ARG), and wherein the means (111) for determining the complex coherence value  $(Qi)$  is arranged for summing the values of the corrected cross-correlation function  $(R'i)$  in at least each one of the frequency sub-bands (i) of the subset.

5. A method of encoding audio signals, the method comprising

- generating (1) a monaural signal (MAS) comprising a combination of at least two input audio signals ( $x(n)$ ,  $y(n)$ ), and
- generating (10) a set of spatial parameters (IPDi; ICi) indicative of spatial properties of the at least two input audio signals ( $x(n)$ ,  $y(n)$ ), wherein the set of spatial parameters (IPDi; ICi) at least comprises an inter-channel coherence value (ICi) and/or an inter-channel phase difference value (IPDi), wherein the means (10) for generating the set of spatial parameters (IPDi; ICi) comprises
- transforming (102, 103) the input audio signals ( $x(n)$ ,  $y(n)$ ) into a frequency domain to obtain audio signals in the frequency domain ( $X(k)$ ,  $Y(k)$ ),
- dividing (104, 105) the audio signals in the frequency domain ( $X(k)$ ,  $Y(k)$ ) into corresponding pluralities of sub-band signals ( $X_i(k)$ ,  $Y_i(k)$ ) associated with frequency sub-bands (i), **characterized by**
- generating (106, 107) a cross-correlation function ( $R_i$ ;  $P_i$ ) for each of the at least two input audio signals ( $x(n)$ ,  $y(n)$ ) from the sub-band signals ( $X_i(k)$ ,  $Y_i(k)$ ) for at least one of the frequency sub-bands (i) belonging to a subset of the frequency sub-bands (i),
- determining (111) a complex coherence value ( $Q_i$ ) by summing values of the cross-correlation function ( $R_i$ ;  $P_i$ ) in each one of the frequency sub-bands (i) of the subset, and
- determining (112) an absolute value of the complex coherence value ( $Q_i$ ) to obtain an estimate of the inter-channel coherence value (ICi) in each one of the frequency sub-bands (i) of the subset, and/or
- determining (113) an argument of the complex coherence value ( $Q_i$ ) to obtain an estimate of the inter-channel phase difference value (IPDi) in each one of the frequency sub-bands (i) of the subset.

Patentansprüche

1. Codierer zum Codieren von Audiosignalen, wobei der Codierer Folgendes umfasst:

- Mittel (1) zum Erzeugen eines Monosignals (MAS) mit einer Kombination wenigstens zweier Eingangsaudiosignale ( $x(n)$ ,  $y(n)$ ), und
- Mittel (10) zum Erzeugen eines Satzes räumlicher Parameter (IPDi; ICi), indikativ für räumliche Eigenschaften der wenigstens zwei Eingangsaudiosignale ( $x(n)$ ,  $y(n)$ ), wobei der Satz räumlicher Parameter (IPDi; ICi) wenigstens einen Zwischenkanalkohärenzwert (ICi) und/oder einen Zwischenkanalphasendifferenzwert (IPDi) aufweist, wobei die Mittel (10) zum Erzeugen des Satzes räumlicher Parameter (IPDi; ICi) die nachfolgenden Mittel aufweist:
- Mittel (102, 103) zum Transformieren der Eingangsaudiosignale ( $x(n)$ ,  $y(n)$ ) in eine Frequenzdomäne zum Erhalten von Audiosignalen in dem Frequenzbereich ( $X(k)$ ,  $Y(k)$ ),
- Mittel (104, 105) zum Aufteilen der Audiosignale in dem Frequenzbereich ( $X(k)$ ,  $Y(k)$ ) in entsprechende Mengen Teilbandsignale ( $X_i(k)$ ,  $Y_i(k)$ ), assoziiert mit Frequenzteilbändern (i), **gekennzeichnet durch:**
- Mittel (106, 107) zum Erzeugen einer Kreuzkorrelationsfunktion ( $R_i$ ;  $P_i$ ) für jedes der wenigstens zwei Eingangsaudiosignale ( $x(n)$ ,  $y(n)$ ) aus den Teilbandsignalen ( $X_i(k)$ ,  $Y_i(k)$ ) für wenigstens eines der Frequenzteilbänder (i), die zu einem Subsatz der Frequenzteilbänder (i) gehören,
- Mittel (111) zum Ermitteln eines komplexen Kohärenzwertes ( $Q_i$ ) **durch** Summierung von Werten der Kreuzkorrelationsfunktion ( $R_i$ ;  $P_i$ ) in jedem der Frequenzteilbänder (i) des Subsatzes, und
- Mittel (112) zum Ermitteln eines Absolutwertes des komplexen Kohärenzwertes ( $Q_i$ ) zum Erhalten einer Schätzung des Zwischenkanalkohärenzwertes (ICi) in jedem der Frequenzteilbänder (i) des Subsatzes, und/oder
- Mittel (113) zum Ermitteln eines Argumentes des komplexen Kohärenzwertes ( $Q_i$ ) zum Erhalten einer Schätzung des Zwischenkanalphasendifferenzwertes (IPDi) in jedem der Frequenzteilbänder (i) des Subsatzes.

2. Codierer zum Codieren von Audiosignalen nach Anspruch 1, wobei die Mittel (106, 107) zum Erzeugen einer Kreuzkorrelationsfunktion ( $R_i$ ;  $P_i$ ) vorgesehen sind zum Berechnen einer komplexen Kreuzkorrelationsfunktion ( $R_i$ ,  $P_i$ ) als eine Multiplikation eines der Teilbandsignale in dem Frequenzbereich ( $X_i(k)$ ) mit dem komplexen konjugierten anderen Signal der Teilbandsignale in dem Frequenzbereich ( $Y_i(k)$ ).

3. Codierer zum Codieren von Audiosignalen nach Anspruch 2, wobei die Mittel (106, 107) zum Erzeugen der Kreuz-

## EP 1 671 316 B1

korrelationsfunktion ( $R_i$ ;  $P_i$ ) vorgesehen sind zum Berechnen einer korrigierten Kreuzkorrelationsfunktion ( $R'_i$ ), welche die Kreuzkorrelationsfunktion ( $R_i$ ) ist, in der das Argument (ARG) durch eine Ableitung (DA) des genannten Argumentes (ARG) ersetzt worden ist, und wobei die Mittel (111) zum Ermitteln des komplexen Kohärenzwertes ( $Q_i$ ) vorgesehen ist zum Summieren der Werte der korrigierten Kreuzkorrelationsfunktion ( $R'_i$ ).

5  
4. Codierer zum Codieren von Audiosignalen nach Anspruch 1, wobei die Mittel (106, 107) zum Erzeugen der Kreuzkorrelationsfunktion ( $R_i$ ;  $P_i$ ) vorgesehen sind zum Berechnen

10  
- für Frequenzteilbänder ( $i$ ) unterhalb einer vorbestimmten Frequenz, der Kreuzkorrelationsfunktion ( $R_i$ ;  $P_i$ ) als eine Multiplikation eines der Teilbandsignale in dem Frequenzbereich ( $X_i(k)$ ) mit dem komplexen konjugierten anderen Signal der Teilbandsignale in dem Frequenzbereich ( $Y_i(k)$ ), wobei die Mittel (111) zum Ermitteln des komplexen Kohärenzwertes ( $Q_i$ ) vorgesehen ist zum Summieren der Werte der Kreuzkorrelationsfunktion ( $R_i$ ;  $P_i$ ) in jedem der Frequenzteilbänder ( $i$ ) des Satzes, und

15  
- für Frequenzteilbänder ( $i$ ) über der vorbestimmten Frequenz, korrigierter Kreuzkorrelationsfunktionen ( $R'_i$ ), welche die Kreuzkorrelationsfunktion ( $R_i$ ) sind, wobei das Argument (ARG) durch eine Ableitung (DA) des genannten Argumentes (ARG) ersetzt worden ist, und wobei die Mittel (111) zum Ermitteln des komplexen Kohärenzwertes ( $Q_i$ ) vorgesehen ist zum Summieren der Werte der korrigierten Kreuzkorrelationsfunktion ( $R'_i$ ) in wenigstens jedem der Frequenzteilbänder ( $i$ ) des Satzes.

20  
5. Verfahren zum Codieren von Audiosignalen, wobei das Verfahren die nachfolgenden Verfahrensschritte umfasst:

- das Erzeugen (1) eines Monosignal (MAS) mit einer Kombination wenigstens zweier Eingangsaudiosignale ( $x(n)$ ,  $y(n)$ ), und

25  
- das Erzeugen (10) eines Satzes räumlicher Parameter (IPDi; ICi), indikativ für räumliche Eigenschaften der wenigstens zwei Eingangsaudiosignale ( $x(n)$ ,  $y(n)$ ), wobei der Satz räumlicher Parameter (IPDi; ICi) wenigstens einen Zwischenkanalkohärenzwert (ICi) und/oder einen Zwischenkanalphasendifferenzwert (IPDi) aufweist, wobei die Mittel (10) zum Erzeugen des Satzes räumlicher Parameter (IPDi; ICi) die nachfolgenden Verfahrensschritte aufweist:

30  
- das Transformieren (102, 103) der Eingangsaudiosignale ( $x(n)$ ,  $y(n)$ ) in eine Frequenzdomäne zum Erhalten von Audiosignalen in dem Frequenzbereich ( $X(k)$ ,  $Y(k)$ ),

- das Aufteilen (104, 105) der Audiosignale in dem Frequenzbereich ( $X(k)$ ,  $Y(k)$ ) in entsprechende Mengen Teilbandsignale ( $X_i(k)$ ,  $Y_i(k)$ ), assoziiert mit Frequenzteilbändern ( $i$ ), **gekennzeichnet durch**:

35  
- das Erzeugen (106, 107) einer Kreuzkorrelationsfunktion ( $R_i$ ;  $P_i$ ) für jedes der wenigstens zwei Eingangsaudiosignale ( $x(n)$ ,  $y(n)$ ) aus den Teilbandsignalen ( $X_i(k)$ ,  $Y_i(k)$ ) für wenigstens eines der Frequenzteilbänder ( $i$ ), die zu einem Subsatz der Frequenzteilbänder ( $i$ ) gehören,

- das Ermitteln (111) eines komplexen Kohärenzwertes ( $Q_i$ ) **durch** Summierung von Werten der Kreuzkorrelationsfunktion ( $R_i$ ;  $P_i$ ) in jedem der Frequenzteilbänder ( $i$ ) des Satzes, und

40  
- das Ermitteln (112) eines Absolutwertes des komplexen Kohärenzwertes ( $Q_i$ ) zum Erhalten einer Schätzung des Zwischenkanalkohärenzwertes (ICi) in jedem der Frequenzteilbänder ( $i$ ) des Satzes, und/oder

45  
- das Ermitteln (113) eines Argumentes des komplexen Kohärenzwertes ( $Q_i$ ) zum Erhalten einer Schätzung des Zwischenkanalphasendifferenzwertes (IPDi) in jedem der Frequenzteilbänder ( $i$ ) des Satzes.

### Revendications

50  
1. Codeur pour coder des signaux audio, le codeur comprenant :

- un moyen (1) pour générer un signal monophonique (MAS) comprenant une combinaison d'au moins deux signaux audio d'entrée ( $x(n)$ ,  $y(n)$ ), et

55  
- un moyen (10) pour générer un ensemble de paramètres spatiaux (IPDi; ICi) indicatifs de propriétés spatiales des au moins deux signaux audio d'entrée ( $x(n)$ ,  $y(n)$ ), où l'ensemble de paramètres spatiaux (IPDi; ICi) comprend au moins une valeur de cohérence entre canaux (ICi) et/ou une valeur de différence de phase entre canaux (IPDi), où le moyen (10) destiné à la génération de l'ensemble de paramètres spatiaux (IPDi; ICi) comprend

- des moyens (102, 103) pour transposer les signaux audio d'entrée ( $x(n)$ ,  $y(n)$ ) dans un domaine fréquentiel



pour obtenir des signaux audio dans le domaine fréquentiel ( $X(k)$ ,  $Y(k)$ ),

- des moyens (104, 105) pour diviser les signaux audio dans le domaine fréquentiel ( $X(k)$ ,  $Y(k)$ ) en pluralités correspondantes de signaux de sous-bande ( $X_i(k)$ ,  $Y_i(k)$ ) associées à des sous-bandes de fréquences (i), **caractérisé par**

- des moyens (106, 107) pour générer une fonction d'intercorrélation ( $R_i$ ;  $P_i$ ) pour chacun des au moins deux signaux audio d'entrée ( $x(n)$ ,  $y(n)$ ) à partir des signaux de sous-bande ( $X_i(k)$ ,  $Y_i(k)$ ) pour au moins une des sous-bandes de fréquences (i) appartenant à un sous-ensemble des sous-bandes de fréquences (i),

- un moyen (111) pour déterminer une valeur de cohérence complexe ( $Q_i$ ) en additionnant des valeurs de la fonction d'intercorrélation ( $R_i$ ;  $P_i$ ) dans chacune des sous-bandes de fréquences (i) du sous-ensemble, et

- un moyen (112) pour déterminer une valeur absolue de la valeur de cohérence complexe ( $Q_i$ ) pour obtenir une estimation de la valeur de cohérence entre canaux ( $IC_i$ ) dans chacune des sous-bandes de fréquences (i) du sous-ensemble, et/ou

- un moyen (113) pour déterminer un argument de la valeur de cohérence complexe ( $Q_i$ ) pour obtenir une estimation de la valeur de différence de phase entre canaux ( $IPDi$ ) dans chacune des sous-bandes de fréquences (i) du sous-ensemble.

2. Codeur pour coder des signaux audio selon la revendication 1, dans lequel les moyens (106, 107) destinés à la génération d'une fonction d'intercorrélation ( $R_i$ ;  $P_i$ ) sont configurés pour calculer une fonction d'intercorrélation complexe ( $R_i$ ;  $P_i$ ) comme une multiplication d'un des signaux de sous-bande dans le domaine fréquentiel ( $X_i(k)$ ) par le complexe conjugué de l'autre signal de sous-bande dans le domaine fréquentiel ( $Y_i(k)$ ).

3. Codeur pour coder des signaux audio selon la revendication 2, dans lequel les moyens (106, 107) destinés à la génération de la fonction d'intercorrélation ( $R_i$ ;  $P_i$ ) sont configurés pour calculer une fonction d'intercorrélation corrigée ( $R'_i$ ) qui est la fonction d'intercorrélation ( $R_i$ ) dans laquelle l'argument (ARG) est remplacé par une dérivée (DA) dudit argument (ARG), et où le moyen (111) destiné à la détermination de la valeur de cohérence complexe ( $Q_i$ ) est configuré pour additionner les valeurs de la fonction d'intercorrélation corrigée ( $R'_i$ ).

4. Codeur pour coder des signaux audio selon la revendication 1, dans lequel les moyens (106, 107) destinés à la génération de la fonction d'intercorrélation ( $R_i$ ;  $P_i$ ) sont configurés pour calculer, pour des sous-bandes de fréquences (i) au-dessous d'une fréquence prédéterminée, la fonction d'intercorrélation ( $R_i$ ;  $P_i$ ) comme une multiplication d'un des signaux de sous-bande dans le domaine fréquentiel ( $X_i(k)$ ) par le complexe conjugué de l'autre signal de sous-bande dans le domaine fréquentiel ( $Y_i(k)$ ), où le moyen (111) destiné à la détermination de la valeur de cohérence complexe ( $Q_i$ ) est configuré pour additionner les valeurs de la fonction d'intercorrélation ( $R_i$ ;  $P_i$ ) dans chacune des sous-bandes de fréquences (i) du sous-ensemble, et,

pour des sous-bandes de fréquences (i) au-dessus de la fréquence prédéterminée, des fonctions d'intercorrélation corrigées ( $R'_i$ ) qui sont la fonction d'intercorrélation ( $R_i$ ) dans laquelle l'argument (ARG) est remplacé par une dérivée (DA) dudit argument (ARG), et où le moyen (111) destiné à la détermination de la valeur de cohérence complexe ( $Q_i$ ) est configuré pour additionner les valeurs de la fonction d'intercorrélation corrigée ( $R'_i$ ) dans, au moins, chacune des sous-bandes de fréquences (i) du sous-ensemble.

5. Procédé de codage de signaux audio, le procédé comprenant

- la génération (1) d'un signal monophonique (MAS) comprenant une combinaison d'au moins deux signaux audio d'entrée ( $x(n)$ ,  $y(n)$ ), et

- la génération (10) d'un ensemble de paramètres spatiaux ( $IPDi$ ;  $IC_i$ ) indicatifs de propriétés spatiales des au moins deux signaux audio d'entrée ( $x(n)$ ,  $y(n)$ ), où l'ensemble de paramètres spatiaux ( $IPDi$ ;  $IC_i$ ) comprend au moins une valeur de cohérence entre canaux ( $IC_i$ ) et/ou une valeur de différence de phase entre canaux ( $IPDi$ ), où le moyen (10) destiné à la génération de l'ensemble de paramètres spatiaux ( $IPDi$ ;  $IC_i$ ) comprend

- la transposition (102, 103) des signaux audio d'entrée ( $x(n)$ ,  $y(n)$ ) dans un domaine fréquentiel pour obtenir des signaux audio dans le domaine fréquentiel ( $X(k)$ ,  $Y(k)$ ),

- la division (104, 105) des signaux audio dans le domaine fréquentiel ( $X(k)$ ,  $Y(k)$ ) en pluralités correspondantes de signaux de sous-bande ( $X_i(k)$ ,  $Y_i(k)$ ) associées à des sous-bandes de fréquences (i), **caractérisé par**

- la génération (106, 107) d'une fonction d'intercorrélation ( $R_i$ ;  $P_i$ ) pour chacun des au moins deux signaux audio d'entrée ( $x(n)$ ,  $y(n)$ ) à partir des signaux de sous-bande ( $X_i(k)$ ,  $Y_i(k)$ ) pour au moins une des sous-bandes de fréquences (i) appartenant à un sous-ensemble des sous-bandes de fréquences (i),

- la détermination (111) d'une valeur de cohérence complexe ( $Q_i$ ) en additionnant des valeurs de la fonction d'intercorrélation ( $R_i$ ;  $P_i$ ) dans chacune des sous-bandes de fréquences (i) du sous-ensemble, et

- la détermination (112) d'une valeur absolue de la valeur de cohérence complexe ( $Q_i$ ) pour obtenir une estimation

## EP 1 671 316 B1

de la valeur de cohérence entre canaux ( $IC_i$ ) dans chacune des sous-bandes de fréquences ( $i$ ) du sous-ensemble, et/ou

- la détermination (113) d'un argument de la valeur de cohérence complexe ( $Q_i$ ) pour obtenir une estimation de la valeur de différence de phase entre canaux ( $IPD_i$ ) dans chacune des sous-bandes de fréquences ( $i$ ) du sous-ensemble.

5

10

15

20

25

30

35

40

45

50

55

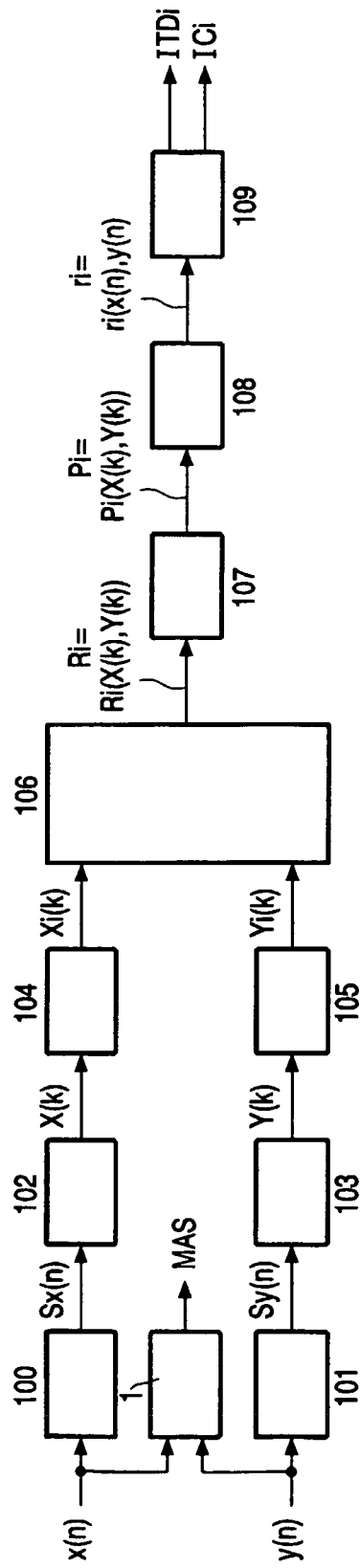

FIG. 1

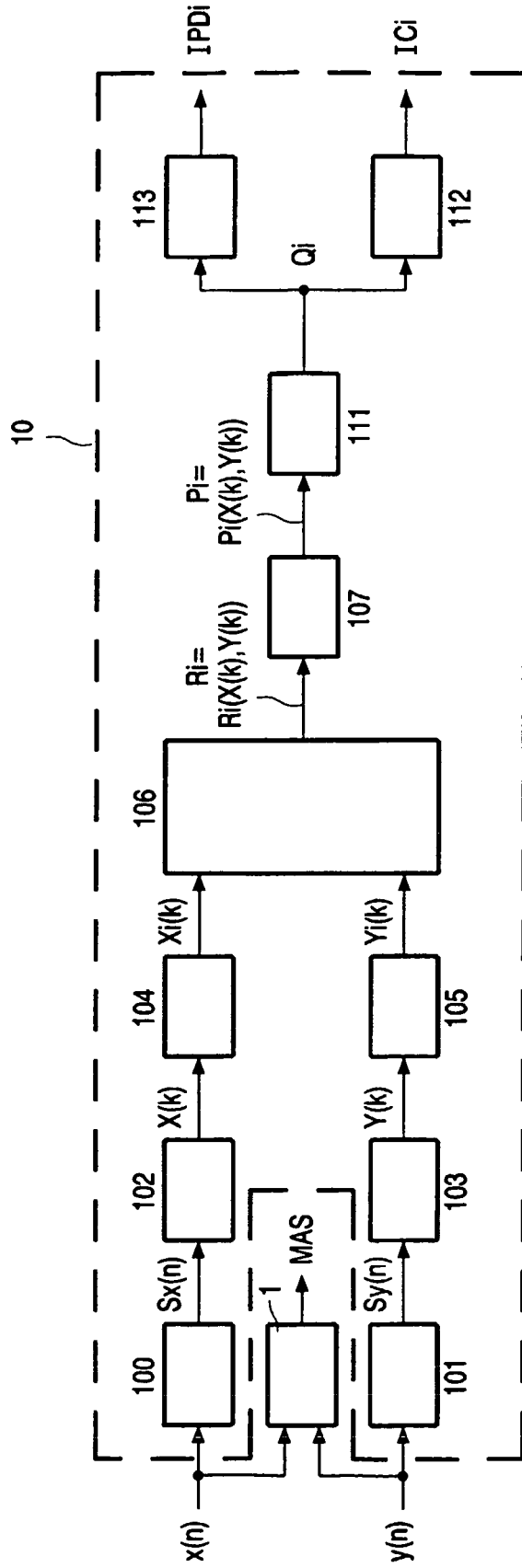

FIG. 2

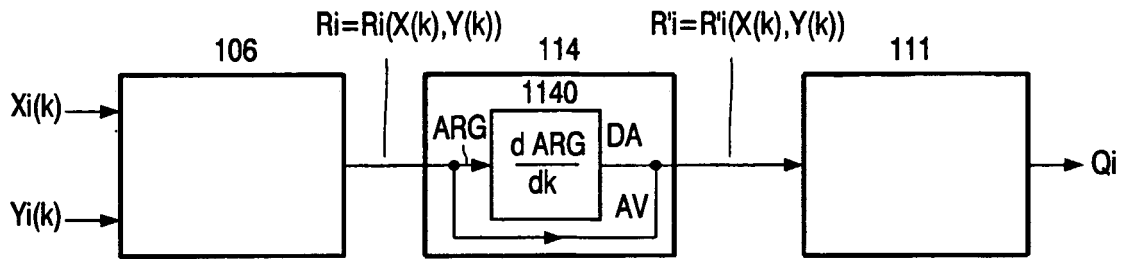

FIG. 3

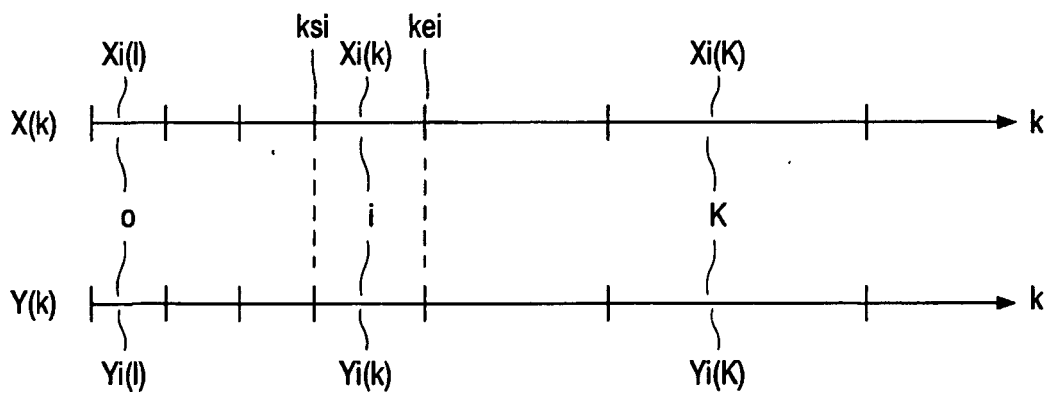

FIG. 4

**REFERENCES CITED IN THE DESCRIPTION**

*This list of references cited by the applicant is for the reader's convenience only. It does not form part of the European patent document. Even though great care has been taken in compiling the references, errors or omissions cannot be excluded and the EPO disclaims all liability in this regard.*

**Patent documents cited in the description**

- US 20030026441 A [0004] [0008] [0011] [0013]